



City of Meriden, Connecticut

Purchasing Department

Invitation to Bid

For

WASHINGTON MIDDLE SCHOOL BOILER REPLACEMENT

Meriden, CT

B024-49

Proposals Due: May 14, 2024 @ 2:00 PM

*Purchasing Department
142 East Main Street, Room 210
Meriden, CT 06450
(203) 630-4115*

LEGAL NOTICE

INVITATION TO BID

The City of Meriden is accepting sealed bids for:

B024-49 – WASHINGTON MIDDLE SCHOOL BOILER REPLACEMENT

The City of Meriden seeks the services of a contractor to furnish labor and materials to replace the boiler at Washington Middle School, 1225 N Broad St, Meriden, CT 06450.

Bids shall be submitted on forms and in the manner specified. Forms and specifications may be obtained from the Purchasing Department, on the City of Meriden website (www.meridenct.gov/business/bids-rfps/), and on the State of Connecticut Department of Administrative Services website (<https://portal.ct.gov/DAS/CTSource>). Bids will be accepted at the Purchasing Department, 142 East Main Street, Room 210, Meriden, Connecticut 06450 until **2:00 P.M. local, eastern standard time on May 14, 2024** at which time they will be publicly opened and read. Any bid received after the time and date specified shall not be considered.

The right is reserved to reject any or all bids, in whole or in part, to award any item, group of items, or total bid, and to waive informality or technical defects, if it is deemed to be in the best interest of the City of Meriden. No bidder may withdraw its bid within sixty (60) days of the date of the bid opening.

There will be a Non-Mandatory Pre-Bid Walkthrough on Thursday, April 19, 2024 at 10:00 AM at 1225 N Broad St, Meriden, CT 06450.

Each bid shall be accompanied by a Certified Check or Bid Bond in the amount of Ten (10%) percent of the amount bid.

Labor and Material Payment Bond and a Performance bond for One Hundred Percent (100%) of the contract price, with a corporate surety approved by the City of Meriden, will be required of the lowest responsible bidder.

The attention of bidders is call to the requirement for minimum wage rates to be paid under this contract.

The City of Meriden is an Affirmative Action/Equal Opportunity Employer. Disadvantaged, minority, small, and women business enterprises are encouraged to respond.

Rawle Dummett
Purchasing Officer
City of Meriden, CT 06450-8022
Dated: April 9, 2024

CITY OF MERIDEN, CONNECTICUT

B024-49 – WASHINGTON MIDDLE SCHOOL BOILER REPLACEMENT

INFORMATION TO BIDDERS

1. BIDDING PROCEDURES

Sealed Bids shall be submitted on the forms designated by the attached proposal bid forms. Bids will be received by the City of Meriden's Purchasing Department, Room 210, City Hall, 142 East Main Street, Meriden, Connecticut, 06450-8022 until 2:00 p.m. on May 14, 2024 and thereafter immediately read in public (the "bid opening").

2. BIDS

Bids are to be submitted on the attached proposal forms. Please submit two copies of the proposal forms and Bidder's Qualification Statement. One shall be an original and one can be a copy. **Please submit one additional complete copy of your bid on a flash drive. BID WILL BE AUTOMATICALLY REJECTED FOR ANYONE SUBMITTING A SURETY OTHER THAN THOSE SPECIFIED.**

- a. Bids must be made out and signed in the corporate, or other, name of Bidder, and must be fully and properly executed by an authorized person.
- b. The sealed envelope must denote the Bidder's name and address in the upper left hand corner and the words "BID DOCUMENT – B024-49 WASHINGTON MIDDLE SCHOOL BOILER REPLACEMENT to be opened at 2:00 p.m." in the lower left hand corner.
- c. Bids received later than the time and date specified will not be considered.
- d. Amendments to or withdrawal of bids received later than the date and time set forth in the bid opening will not be considered.
- e. All prices must be in ink or typewritten. In the event of a bidder's mathematical error in tabulating any bid prices, *the written unit prices shall govern.*

3. BIDDER QUALIFICATIONS

Bidders will be required to fill out, and include as part of its bid, any attached Bidder's Qualification Statement.

In determining the qualifications of a bidder, the City of Meriden will consider the bidder's record of performance in any prior contracts for construction work. The City of Meriden expressly reserves the right to reject a bid if the bidder's historical performance, in the sole opinion of the City of Meriden, has been unsatisfactory in any manner or if the bidder has habitually and without just cause neglected the payment of bills or has otherwise disregarded its obligations to subcontractors, suppliers, or employees.

4. EXAMINATION OF BIDDING DOCUMENTS

Bidders are to examine all documents and visit the site in order to make a thorough examination of the conditions so that the bidder may familiarize itself with all of the existing requirements, conditions, and difficulties that will affect the execution of the work in order to determine the amount of work necessary to carry out the true intent of the specifications and work shown on the drawings.

The City of Meriden and its agents do not have any responsibility for the accuracy, completeness, or sufficiency of any bid document obtained from any other source other than from the City of Meriden. Obtaining documents from any other source(s) may result in obtaining incomplete and inaccurate information. Obtaining documents from any other source may also result in failure to receive any addenda, corrections, or other revisions to the documents that may be issued.

No request shall be honored if such request is made less than seven (7) calendar days prior to the date fixed for the opening of bids. Any and all such interpretations, and any supplementary instructions, will be in the form of a written addenda to the specifications which, if issued, will be made available on the City of Meriden website (www.meridenct.gov) unless it is to change the date fixed for the opening of bids, not later than three (3) days prior to the date fixed for the opening of bids. Bidders are encouraged to check the website regularly for addenda. Failure of any bidder to receive any such addenda shall not relieve any bidder from any obligations under its bid as submitted.

Any questions about the bid document must be submitted in writing via email to meridenpurchasing@meridenct.gov. Any other format of question will not be answered.

5. BIDS TO REMAIN OPEN

No bidder may withdraw its bid within sixty (60) days of the date of the bid opening. Should there be reason why the contract cannot be awarded within the specified period, the time may be extended by mutual agreement between the City of Meriden and the successful bidder.

6. AWARD OF CONTRACT

The Purchasing Officer reserves the right to make an award on the bid which, by the Purchasing Officer's judgment and recommendation from the Department of Facilities following bid evaluations, best meets the specifications and is deemed to be in the best interest of the City of Meriden.

The contract will not be awarded to any corporation, firm, or individual which/who is in arrears to the City of Meriden by debt or contract, or who is in default as security or otherwise by any obligation to the City of Meriden.

The right is reserved to reject any or all bids, in whole or in part, to award any item, group of items, or total bid, and to waive informality or technical defects, if it is deemed to be in the best interest of the City of Meriden.

7. BID PROTEST PROCEDURE

In the event that any bidder wishes to protest the potential award of a bid, or any procedure of act in the advertising or soliciting of the bids, said bidder must make said protest in writing, which shall state the reason therefore and request a conference with respect thereto. Said protest must be received in the City Purchasing Office within **FIVE (5)** business days after the delivery of bid results or decisions. A conference with respect to said protest shall be scheduled by the Purchasing Officer forthwith and shall be attended by him or his designee and such other persons as the Purchasing Officer and the City Manager shall require to attend. The subject matter of said conference shall be limited to the reasons for the protest specified in the written request for said conference. Said conference shall also include a discussion of all possibilities for a resolution of dispute. The City shall make a decision in writing within three (3) business days after said conference and forward the same to the protesting bidder forthwith. In the event that any protesting bidder wishes to take legal action against the City, they must fully comply with all of these instructions to bidders.

8. CITY OF MERIDEN, LOCAL PREFERENCE

In determining the lowest responsible bidder, the Purchasing Department shall also consider Local Preference.

This section shall not apply in those instances where the bid requested involves a cooperative purchasing arrangement between the City of Meriden and other municipalities or the State of Connecticut.

Bidders are specifically advised that the City of Meriden has adopted Section 3-14 of the Code of the City of Meriden which requires, but is not limited to, a local preference requiring, in part, that a “City-based business” shall mean a business with its principal place of business located within the boundaries of the City of Meriden. A business shall not be considered a “City-based business” unless evidence has been submitted, satisfactory to the Purchasing Department, with each bid (forms included in bidding documents) to establish that the bidder has a bona fide principal place of business, operates out of, or pays property taxes on personal property in the City of Meriden.

Any City-based business bidder which has submitted a bid not more than ten (10) percent higher than the low bid provided such City-based business bidder agrees to accept the award of the bid at the amount of the low bid. The acceptance shall be submitted in writing to the Purchasing Department no later than next business day following the opening of the bid. For example, a bid opened at 11:00 a.m. on a Monday must be accepted by the City-based bidder no later than 11:00 a.m. on Tuesday. If more than one City-based business bidder has submitted bids not more than ten (10) percent higher than the low bid and has agreed to

accept the award of the bid at the amount of the low bid, the lowest responsible bidder shall be one of the City-based business bidders which has submitted the lowest bid.

Bidders claiming status under the local preference are hereby required to submit with its bid an additional form, titled "Request for Status as a Meriden Based Business."

9. EXTENSION OF AGREEMENT – N/A

10. TIME

Inasmuch as the contract concerns a public improvement, the provisions of the contract relating to the time of performance and completion of the work are of the essence of the contract. Accordingly, the successful bidder/contractor ("Contractor") shall begin work on the day specified in paragraph 2.04 of the General Conditions and shall perform the work diligently so as to permit full use not later than the first day following the construction period established in the Contract. See paragraph 10 entitled "Liquidated Damages" of the Agreement between City of Meriden, as owner, and the Contractor.

11. SCHEDULE OF WORK

The Contractor shall schedule all work in a manner that will not disrupt City of Meriden operations. Once the work has begun, the Contractor shall work full-time until completion of the Contract.

12. TAXES

The City of Meriden is exempt under Connecticut General Statutes from the payment of the excise taxes imposed by the federal government and the Sales and Use Tax of the State of Connecticut; such taxes should not be included in the bid price. Upon request, exemption certificates will be furnished to the successful bidder.

13. FAIR EMPLOYMENT PRACTICES

The Contractor shall agree that neither it or its subcontractors, except in the case of a bona fide occupational qualification or need, to refuse to hire or employ or to bar or to discharge from employment any individual or to discriminate against such individual in compensation or in terms, conditions or privileges of employment because of the individual's race, color, religious creed, age, sex, gender identity or expression, marital status, national origin, ancestry, present or past history of mental disability, intellectual disability, learning disability, physical disability, including, but not limited to, blindness or status as a veteran. The aforementioned terms are obtained from Connecticut General Statutes Section 46a-60, *et seq.*, entitled "Discriminatory employment practices prohibited," as amended.

14. FORM OF AGREEMENT BETWEEN CITY OF MERIDEN AND CONTRACTOR

The Agreement for the work will be written on the Agreement between City of Meriden and Contractor, wherein the basis of payment is a stipulated sum.

15. LOCAL SUBCONTRACTORS, SUPPLIERS, etc.

Local subcontractors, material suppliers, and labor in the City of Meriden should be considered and sought out insofar as it is practical in the performance of this project.

16. CITY OF MERIDEN CODE OF ETHICS

The City of Meriden has adopted a Code of Ethics located in Chapter 21 of the Code of the City of Meriden, sections 21-1 through 21-15, inclusive, which are expressly incorporated herein by reference. The terms of the Code of Ethics shall constitute a part of any contract or agreement entered into by the City of Meriden as a result of this bid as if those terms were fully set forth in such contract or agreement.

Bidders are specifically advised that the Code of Ethics prohibits public officers and employees, as well as their immediate families and businesses, with which they are associated from participating in any transaction which is incompatible with the proper discharge of official duties or responsibilities. Bidders are also advised that the Code of Ethics contain provisions with respect to paid contractors and former employees and officials.

BIDDERS SHOULD NOTE THAT BIDS, CONTRACTS, AND AGREEMENTS ENTERED INTO OR AWARDED IN VIOLATION OF THE CODE OF ETHICS ARE VOIDABLE BY RESOLUTION OF THE CITY COUNCIL OF THE CITY OF MERIDEN.

Copies of the Code of Ethics may be obtained from the office of the City Clerk or may be found online on the City of Meriden's website.

17. NON-COLLUSION BID STATEMENT

Each bidder submitting a bid to the City of Meriden for any portion of the work contemplated by the documents on which bidding is based shall execute and attach thereto the sworn Non-Collusive Bid Statement, to the effect that the bidder has not colluded with any other person, firm, or corporation in the submission of the bid.

18. SOIL CONDITIONS

The City of Meriden does not guarantee the accuracy of any information which it may have obtained as to the kind or condition of the soil that may be encountered in the performance of the proposed work; neither does the City of Meriden represent that the plans and specifications drawn are based upon any soil data so obtained. The City of Meriden does not

make any representations as to the soil data so obtained. The City of Meriden does not make any representations as to the soil conditions to be encountered or as to foundation materials.

19. AWARD IN CASE OF A TIE

In the event there are two or more responsive bidders, the decision to award will be based by the following criteria and in the following order:

- a. The incumbent will be awarded the bid over that of another bidder.
- b. In the case of a multi-item bid, if one bidder has been awarded other items from the same bid and the other bidder has not, the bidder with the multiple awards will be awarded the bid over that of another bidder.
- c. The bidder located in the State of Connecticut will be awarded the bid over that of another bidder.
- d. The winner of a coin toss will be awarded the bid over that of another bidder.

The above-referenced provisions do not apply to those situations in which more than one City-based business responsible bidder has submitted bids not more than ten (10) percent higher than the lowest bid and has agreed to accept the award of the bid at the amount of the lowest bid. Under such circumstances, the provisions of the Code of the City of Meriden, section 3-14, are controlling, as set forth under Section 8 of this 'Information to Bidders.'

20. ASSIGNMENT OF CONTRACT

No contract may be assigned without the written consent of the Purchasing Officer or designee.

21. PERMITS

The Contractor shall be responsible for obtaining any and all necessary permits required by the City of Meriden prior to the commencement of work. The Contractor may contact the City of Meriden Building Department for permit information at (203) 630-4091. For all other required permits, contact the City of Meriden Engineering Department at (203) 630-4018.

22. BID PRICE AND PAYMENT

The City of Meriden is exempt from the payment of the excise taxes imposed by the Federal government and the Sales and Use Tax of the State of Connecticut under Connecticut General Statutes; accordingly, such taxes shall not be included in the bid price.

The City of Meriden, unless stated otherwise in the bidding documents or Contract, will make payment to the Contractor not less than thirty (30) days following completion of services.

23. QUALITY

All materials, equipment, supplies, and services shall be subject to rigid inspection. If defective material, equipment, supplies, or services are discovered, the Contractor shall remove or make good such material, equipment, or supplies without extra compensation. It is expressly understood and agreed that any inspection by the City of Meriden will in no way lessen the responsibility of the Contractor or release Contractor from the obligation to perform and deliver to the City sound and satisfactory materials, equipment, supplies, or allow the cost to be deducted from any monies due it from the City of Meriden. All services will be performed in a workmanlike manner.

24. INSURANCE

The successful bidder shall be required to provide a Certificate of Insurance denoting general liability, automobile liability, workers compensation liability, and other coverage required by the City's Risk Manager.

25. CITY HALL CLOSING

If Meriden City Hall is closed due to inclement weather, or any other unforeseen event, bids will be due at the same time on the next business day that City Hall is open.

CITY OF MERIDEN, CONNECTICUT

B024-49 – WASHINGTON MIDDLE SCHOOL BOILER REPLACEMENT

REQUEST FOR STATUS AS A MERIDEN-BASED BUSINESS

Bidders are specifically advised that the City of Meriden has adopted Section 3-14 of the Code of the City of Meriden which requires, but is not limited to, a local preference requiring, in part, that a “City-based business” shall mean a business with its principal place of business located within the boundaries of the City of Meriden. A business shall not be considered a “City-based business” unless evidence satisfactory to the Purchasing Department has been submitted with each bid by said business to establish that it has a bona fide principal place of business in the City of Meriden. Such evidence may include evidence of ownership or a long term lease of the real estate from which the principal place of business is operated, or payment of property taxes on the personal property of the business.

In determining the lowest responsible bidder, the Purchasing Department shall also consider the following:

Any City-based business bidder which has submitted a bid not more than ten (10%) percent higher than the low bid. Such City-based business shall agree to accept the award of the bid at the amount of the low bid. The acceptance shall be submitted in writing to the Purchasing Department no later than the same time of the bid opening on the next business day following the opening of the bid.

If more than one City based business bidder have submitted bids not more than ten (10%) percent higher than the low bid and have agreed to accept the award of the bid at the amount of the low bid, the lowest responsible bidder shall be that one which has submitted the lowest bid.

This section shall not apply in those instances where the bid requested involves a cooperative purchasing arrangement between the City of Meriden and other municipalities or the State of Connecticut.

The bidder may submit any additional information he/she desires that he/she feels establishes the company as a city based business, including but not limited to; evidence of ownership, a long term lease of the real estate from which the principal place of business is operated, or payment of property taxes on the personal property of the business.

1) Name of Bidder: _____

2) Meriden Office Address: _____

3) Minority owned: Yes _____ No _____

- 4) The undersigned hereby authorizes and requests any persons, firms, or corporations to furnish any information requested by the City of Meriden, in verification of the recitals comprising this Request for Status as a City Based Business.

Dated at: _____ this: _____ day of _____, 20 _____

Name of bidder: _____

By: _____

Title: _____

IF REQUESTING STATUS AS A MERIDEN-BASED BUSINESS, SUBMIT THIS FORM WITH YOUR PROPOSAL.

1. Minority owned business? _____ yes _____ no
2. Years organized. _____
3. Is your company a corporation _____ yes _____ no
If yes where incorporated? _____
4. How many years have you been engaged in business under your present firm name? _____
5. Former Firm Name (if any) _____
6. List total number of Personnel _____
7. Is any principal of your firm an employee or public official of the City of Meriden, or an immediate family member of an employee or public official of the City of Meriden? (Definition of immediate family includes: an individual's spouse, fiancé or fiancée; the parent, brother or sister of such individual or spouse; and the child of such individual or the spouse of such child.)
_____ yes _____ no
8. List Vehicles and Equipment that you will use to perform this work: (show age of vehicles and equipment, sizes, capacities, etc.)

9. List the work to be performed by Subcontractors and summarize the dollar value of each subcontract.

10. List the name and address of the more important contracts recently completed by you, starting the approximate gross cost for each, and the month and year completed:

11. General character of work performed by you _____

12. Have you ever failed to complete any contract awarded to you? If so, where and why?

13. Have you ever defaulted on a contract? If so where and why?

14. Have you ever filed bankruptcy: _____ Please explain: _____

15. Will you, upon request, furnish any information that may be required by the City of Meriden? _____
16. The undersigned hereby authorizes and request any person, firm or cooperation to furnish any information requested by the City of Meriden, in verification of the recitals comprising this Statement of Bidder's Qualifications.

Dated this _____ day of _____, 20____ year

 Name of Bidder

 Title

State of _____
 County of _____

_____ being duly sworn deposes and says that they are
 Name _____ of _____
 title _____ name of organization
 and that the answers to the forgoing question and all statement therein contained are true and correct

Subscribed and sworn to before me
 this _____ day of _____ 20____
 day month year

 Notary Public signature

My commission expires _____

FORM OF SURETY GUARANTY

(Shall accompany proposal)

KNOW ALL MEN BY THESE PRESENTS, that for and in consideration of the sum of \$1.00, lawful money of the United States, the receipt whereof is hereby acknowledged, paid the undersaid corporation, and for other valuable consideration the

(Name of Surety Company) .

a corporation organized and existing under the laws of the State of _____

and licensed to do business in the State of _____ certifies and agrees

that if Contract _____

is awarded to - _____
(Name of Bidder)

Corporation will execute the bond or bonds as required by the Contract Documents and will become surety in the full amount of the Contract price for the faithful performance of the Contract and for payment of all persons supplying labor or furnishing or furnishing materials in connection thencewith.

(Surety)

The language of this form shall generally be given on the official form normally provided by the Surety Company complete with the usual proof of Authority of Officers of the Surety Company to execute said official form.

Should a bid be offered with a check as surety without said official form, such bid shall be rejected.

BID BOND

KNOW ALL MEN BY THESE PRESENTS, that we, the undersigned _____,
(Name of Principal)

As Principal, and _____,
(Name of Surety), as Surety are firmly bound

Unto the CITY OF MERIDEN, CONNECTICUT hereinafter called the "OWNER", in the penal sum of

_____ DOLLARS, (\$ _____) lawful money of the
United States, for the payment of which sum well and truly to be made, we bind ourselves, our heirs, executors,
administrators, successors and assigns, jointly and severally, firmly by these presents:

THE CONDITION OF THIS OBLIGATION IS SUCH THAT, WHEREAS, the said Principal has submitted the Accompanying bid
dated _____, 20 _____

For _____

NOW, THEREFORE, if the Principal shall not withdraw said Bid within the Period specified therein after the opening of
the same, or if no period be specified, within thirty (30) days after the said opening and shall within the period
specified therefore, or if no period be specified, within ten (10) days after the prescribed forms are presented to him
for signature, enter into a written Contract with the Owner in accordance with the Bid, as accepted, and give bond
with good and sufficient surety or sureties, as may be required for the faithful performance and proper fulfillment of
such Contract; or in the event of the withdrawal of said Bid within the period specified, or the failure to enter into such
Contract and give such bond within the time specified, if the Principal shall pay the Owner the difference between the
amount specified in said Bid and the Amount for which the Owner may procure the required work or supplies or both,
if the latter be in excess of the former, then the above obligation shall be void and of no effect, otherwise to remain in
full force and effect.

IN WITNESS WHEREOF, the Principal and the Surety have hereunto set their hands and seals, this _____ day of
_____, 20 _____.

(Principal)

(Address) (Affix seal)

By: _____

Witness Signature

(Surety)

(Address) (Affix seal)

By: _____

Witness Signature

BID FORM

B024-49

**WASHINGTON MIDDLE SCHOOL
BOILER REPLACEMENT**

Date of Opening: May 14,2024
At 2:00 PM

To: Rawle Dummett
Purchasing Officer
142 East Main Street, Room 210
Meriden, CT 06450

The undersigned _____, doing business in the City/Town of _____, in the State of _____, herewith, after reading thoroughly the Specifications and other Bid documents (including if any addendum or addenda) submit the following proposal:

Lump sum price:

_____ Dollars & Cents
Written Amount

Receipt of Addenda is acknowledged:

No: _____ Dated: _____

No: _____ Dated: _____

NAME OF BIDDER _____

ADDRESS _____

BY: _____
Print or type name Title

SIGNATURE _____ DATE _____

TELEPHONE _____ E-Mail _____

PLEASE NOTE: All spaces must be filled in with figures or words or your bid may be automatically rejected.



Opportunity * Guidance * Support



THIS IS A PUBLIC WORKS PROJECT

Covered by the

PREVAILING WAGE LAW

CT General Statutes Section 31-53

**If you have QUESTIONS regarding your wages
CALL (860) 263-6790**

Section 31-55 of the CT State Statutes requires every contractor or subcontractor performing work for the state to post in a prominent place the prevailing wages as determined by the Labor Commissioner.

Sec. 31-53b. Construction safety and health course. New miner training program. Proof of completion required for mechanics, laborers and workers on public works projects. Enforcement. Regulations. Exceptions. (a) Each contract for a public works project entered into on or after July 1, 2009, by the state or any of its agents, or by any political subdivision of the state or any of its agents, described in subsection (g) of section 31-53, shall contain a provision requiring that each contractor furnish proof with the weekly certified payroll form for the first week each employee begins work on such project that any person performing the work of a mechanic, laborer or worker pursuant to the classifications of labor under section 31-53 on such public works project, pursuant to such contract, has completed a course of at least ten hours in duration in construction safety and health approved by the federal Occupational Safety and Health Administration or, has completed a new miner training program approved by the Federal Mine Safety and Health Administration in accordance with 30 CFR 48 or, in the case of telecommunications employees, has completed at least ten hours of training in accordance with 29 CFR 1910.268.

(b) Any person required to complete a course or program under subsection (a) of this section who has not completed the course or program shall be subject to removal from the worksite if the person does not provide documentation of having completed such course or program by the fifteenth day after the date the person is found to be in noncompliance. The Labor Commissioner or said commissioner's designee shall enforce this section.

(c) Not later than January 1, 2009, the Labor Commissioner shall adopt regulations, in accordance with the provisions of chapter 54, to implement the provisions of subsections (a) and (b) of this section. Such regulations shall require that the ten-hour construction safety and health courses required under subsection (a) of this section be conducted in accordance with federal Occupational Safety and Health Administration Training Institute standards, or in accordance with Federal Mine Safety and Health Administration Standards or in accordance with 29 CFR 1910.268, as appropriate. The Labor Commissioner shall accept as sufficient proof of compliance with the provisions of subsection (a) or (b) of this section a student course completion card issued by the federal Occupational Safety and Health Administration Training Institute, or such other proof of compliance said commissioner deems appropriate, dated no earlier than five years before the commencement date of such public works project.

(d) This section shall not apply to employees of public service companies, as defined in section 16-1, or drivers of commercial motor vehicles driving the vehicle on the public works project and delivering or picking up cargo from public works projects provided they perform no labor relating to the project other than the loading and unloading of their cargo.

(P.A. 06-175, S. 1; P.A. 08-83, S. 1.)

History: P.A. 08-83 amended Subsec. (a) by making provisions applicable to public works project contracts entered into on or after July 1, 2009, replacing provision re total cost of work with reference to Sec. 31-53(g), requiring proof in certified payroll form that new mechanic, laborer or worker has completed a 10-hour or more construction safety course and adding provision re new miner training program, amended Subsec. (b) by substituting "person" for "employee" and adding "or program", amended Subsec. (c) by adding "or in accordance with Federal Mine Safety and Health Administration Standards" and setting new deadline of January 1, 2009, deleted former Subsec. (d) re "public building", added new Subsec. (d) re exemptions for public service company employees and delivery drivers who perform no labor other than delivery and made conforming and technical changes, effective January 1, 2009.

STATUTE 31-55a

- SPECIAL NOTICE -

To: All State and Political Subdivisions, Their Agents, and Contractors

Connecticut General Statute 31-55a - Annual adjustments to wage rates by contractors doing state work.

Each contractor that is awarded a contract on or after October 1, 2002, for (1) the construction of a state highway or bridge that falls under the provisions of section 31-54 of the general statutes, or (2) the construction, remodeling, refinishing, refurbishing, rehabilitation, alteration or repair of any public works project that falls under the provisions of section 31-53 of the general statutes shall contact the Labor Commissioner on or before July first of each year, for the duration of such contract, to ascertain the prevailing rate of wages on an hourly basis and the amount of payment or contributions paid or payable on behalf of each mechanic, laborer or worker employed upon the work contracted to be done, and shall make any necessary adjustments to such prevailing rate of wages and such payment or contributions paid or payable on behalf of each such employee, effective each July first.

- The prevailing wage rates applicable to any contract or subcontract awarded on or after October 1, 2002 are subject to annual adjustments each July 1st for the duration of any project which was originally advertised for bids on or after October 1, 2002.
- Each contractor affected by the above requirement shall pay the annual adjusted prevailing wage rate that is in effect each July 1st, as posted by the Department of Labor.
- It is the **contractor's** responsibility to obtain the annual adjusted prevailing wage rate increases directly from the Department of Labor's Web Site. The annual adjustments will be posted on the Department of Labor Web page: www.ctdol.state.ct.us. For those without internet access, please contact the division listed below.
- The Department of Labor will continue to issue the initial prevailing wage rate schedule to the Contracting Agency for the project. All subsequent annual adjustments will be posted on our Web Site for contractor access.

Any questions should be directed to the Contract Compliance Unit, Wage and Workplace Standards Division, Connecticut Department of Labor, 200 Folly Brook Blvd., Wethersfield, CT 06109 at (860)263-6790.

~NOTICE~

TO ALL CONTRACTING AGENCIES

Please be advised that Connecticut General Statutes Section 31-53, requires the contracting agency to certify to the Department of Labor, the total dollar amount of work to be done in connection with such public works project, regardless of whether such project consists of one or more contracts.

Please find the attached “Contracting Agency Certification Form” to be completed and returned to the Department of Labor, Wage and Workplace Standards Division, Public Contract Compliance Unit.

 Inquiries can be directed to (860)263-6543.

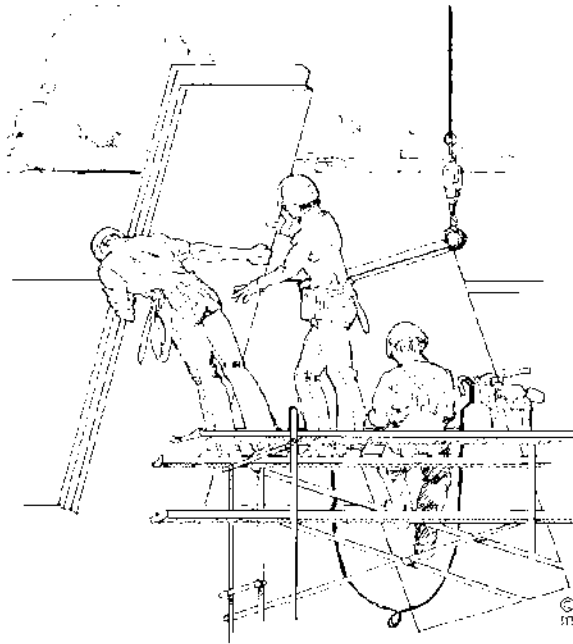

CONNECTICUT DEPARTMENT OF LABOR
WAGE AND WORKPLACE STANDARDS DIVISION
CONTRACT COMPLIANCE UNIT

CONTRACTING AGENCY CERTIFICATION FORM

I, _____, acting in my official capacity as _____,
authorized representative title

for _____, located at _____,
contracting agency address

do hereby certify that the total dollar amount of work to be done in connection with
_____, located at _____,
project name and number address

shall be \$_____, which includes all work, regardless of whether such project
consists of one or more contracts.

CONTRACTOR INFORMATION

Name: _____

Address: _____

Authorized Representative: _____

Approximate Starting Date: _____

Approximate Completion Date: _____

Signature

Date

Return To: Connecticut Department of Labor
Wage & Workplace Standards Division
Contract Compliance Unit
200 Folly Brook Blvd.
Wethersfield, CT 06109

Date Issued: _____

CONNECTICUT DEPARTMENT OF LABOR
WAGE AND WORKPLACE STANDARDS DIVISION

CONTRACTORS WAGE CERTIFICATION FORM
Construction Manager at Risk/General Contractor/Prime Contractor

I, _____ of _____
Officer, Owner, Authorized Rep. Company Name

do hereby certify that the _____
Company Name

Street

City

and all of its subcontractors will pay all workers on the

Project Name and Number

Street and City

the wages as listed in the schedule of prevailing rates required for such project (a copy of which is attached hereto).

Signed

Subscribed and sworn to before me this _____ day of _____, _____.

Notary Public

Return to:

Connecticut Department of Labor
Wage & Workplace Standards Division
200 Folly Brook Blvd.
Wethersfield, CT 06109

Rate Schedule Issued (Date): _____

Informational Bulletin

THE 10-HOUR OSHA CONSTRUCTION SAFETY AND HEALTH COURSE

(applicable to public building contracts entered into *on or after July 1, 2007*, where the total cost of all work to be performed is at least \$100,000)

- (1) This requirement was created by Public Act No. 06-175, which is codified in Section 31-53b of the Connecticut General Statutes (pertaining to the prevailing wage statutes);
- (2) The course is required for public building construction contracts (projects funded in whole or in part by the state or any political subdivision of the state) entered into on or after July 1, 2007;
- (3) It is required of private employees (not state or municipal employees) and apprentices who perform manual labor for a general contractor or subcontractor on a public building project where the total cost of all work to be performed is at least \$100,000;
- (4) The ten-hour construction course pertains to the ten-hour Outreach Course conducted in accordance with federal OSHA Training Institute standards, and, for telecommunications workers, a ten-hour training course conducted in accordance with federal OSHA standard, 29 CFR 1910.268;
- (5) The internet website for the federal OSHA Training Institute is http://www.osha.gov/fso/ote/training/edcenters/fact_sheet.html;
- (6) The statutory language leaves it to the contractor and its employees to determine who pays for the cost of the ten-hour Outreach Course;
- (7) Within 30 days of receiving a contract award, a general contractor must furnish proof to the Labor Commissioner that all employees and apprentices performing manual labor on the project will have completed such a course;
- (8) Proof of completion may be demonstrated through either: (a) the presentation of a *bona fide* student course completion card issued by the federal OSHA Training Institute; *or* (2) the presentation of documentation provided to an employee by a trainer certified by the Institute pending the actual issuance of the completion card;
- (9) Any card with an issuance date more than 5 years prior to the commencement date of the construction project shall not constitute proof of compliance;

- (10) Each employer shall affix a copy of the construction safety course completion card to the certified payroll submitted to the contracting agency in accordance with Conn. Gen. Stat. § 31-53(f) on which such employee's name first appears;
- (11) Any employee found to be in non-compliance shall be subject to removal from the worksite if such employee does not provide satisfactory proof of course completion to the Labor Commissioner by the fifteenth day after the date the employee is determined to be in noncompliance;
- (12) Any such employee who is determined to be in noncompliance may continue to work on a public building construction project for a maximum of fourteen consecutive calendar days while bringing his or her status into compliance;
- (13) The Labor Commissioner may make complaint to the prosecuting authorities regarding any employer or agent of the employer, or officer or agent of the corporation who files a false certified payroll with respect to the status of an employee who is performing manual labor on a public building construction project;
- (14) The statute provides the minimum standards required for the completion of a safety course by manual laborers on public construction contracts; any contractor can exceed these minimum requirements; and
- (15) Regulations clarifying the statute are currently in the regulatory process, and shall be posted on the CTDOL website as soon as they are adopted in final form.
- (16) Any questions regarding this statute may be directed to the Wage and Workplace Standards Division of the Connecticut Labor Department via the internet website of <http://www.ctdol.state.ct.us/wgwkstnd/wgemenu.htm>; or by telephone at (860)263-6790.

THE ABOVE INFORMATION IS PROVIDED EXCLUSIVELY AS AN EDUCATIONAL RESOURCE, AND IS NOT INTENDED AS A SUBSTITUTE FOR LEGAL INTERPRETATIONS WHICH MAY ULTIMATELY ARISE CONCERNING THE CONSTRUCTION OF THE STATUTE OR THE REGULATIONS.

November 29, 2006

Notice
To All Mason Contractors and Interested Parties
Regarding Construction Pursuant to Section 31-53 of the
Connecticut General Statutes (Prevailing Wage)

The Connecticut Labor Department Wage and Workplace Standards Division is empowered to enforce the prevailing wage rates on projects covered by the above referenced statute.

Over the past few years the Division has withheld enforcement of the rate in effect for workers who operate a forklift on a prevailing wage rate project due to a potential jurisdictional dispute.

The rate listed in the schedules and in our Occupational Bulletin (see enclosed) has been as follows:

Forklift Operator:

- **Laborers (Group 4) Mason Tenders** - operates forklift solely to assist a mason to a maximum height of nine feet only.
- **Power Equipment Operator (Group 9)** - operates forklift to assist any trade and to assist a mason to a height over nine feet.

The U.S. Labor Department conducted a survey of rates in Connecticut but it has not been published and the rate in effect remains as outlined in the above Occupational Bulletin.

Since this is a classification matter and not one of jurisdiction, effective January 1, 2007 the Connecticut Labor Department will enforce the rate on each schedule in accordance with our statutory authority.

Your cooperation in filing appropriate and accurate certified payrolls is appreciated.

Information Bulletin ***Occupational Classifications***

The Connecticut Department of Labor has the responsibility to properly determine "job classification" on prevailing wage projects covered under C.G.S. Section 31-53(d).

Note: This information is intended to provide a sample of some occupational classifications for guidance purposes only. It is not an all-inclusive list of each occupation's duties. This list is being provided only to highlight some areas where a contractor may be unclear regarding the proper classification. If unsure, the employer should seek guidelines for CTDOL.

Below are additional clarifications of specific job duties performed for certain classifications:

- **ASBESTOS WORKERS**

Applies all insulating materials, protective coverings, coatings and finishes to all types of mechanical systems.

- **ASBESTOS INSULATOR**

Handle, install apply, fabricate, distribute, prepare, alter, repair, dismantle, heat and frost insulation, including penetration and fire stopping work on all penetration fire stop systems.

- **BOILERMAKERS**

Erects hydro plants, incomplete vessels, steel stacks, storage tanks for water, fuel, etc. Builds incomplete boilers, repairs heat exchanges and steam generators.

- **BRICKLAYERS, CEMENT MASONS, CEMENT FINISHERS, MARBLE MASONS, PLASTERERS, STONE MASONS, PLASTERERS. STONE MASONS, TERRAZZO WORKERS, TILE SETTERS**

Lays building materials such as brick, structural tile and concrete cinder, glass, gypsum, terra cotta block. Cuts, tools and sets marble, sets stone, finishes concrete, applies decorative steel, aluminum and plastic tile, applies cements, sand, pigment and marble chips to floors, stairways, etc.

- **CARPENTERS, MILLWRIGHTS. PILEDRIVERMEN. LATHERS. RESILEINT FLOOR LAYERS, DOCK BUILDERS, DIKERS, DIVER TENDERS**

Constructs, erects, installs and repairs structures and fixtures of wood, plywood and wallboard. Installs, assembles, dismantles, moves industrial machinery. Drives piling into ground to provide foundations for structures such as buildings and bridges, retaining walls for earth embankments, such as cofferdams. Fastens wooden, metal or rockboard lath to walls, ceilings and partitions of buildings, acoustical tile layer, concrete form builder. Applies firestopping materials on fire resistive joint systems only. Installation of curtain/window walls only where attached to wood or metal studs. Installation of insulated material of all types whether blown, nailed or attached in other ways to walls, ceilings and floors of buildings. Assembly and installation of modular furniture/furniture systems. Free-standing furniture is not covered. This includes free standing: student chairs, study top desks, book box desks, computer furniture, dictionary stand, atlas stand, wood shelving, two-position information access station, file cabinets, storage cabinets, tables, etc.

- **LABORER, CLEANING**

- The clean up of any construction debris and the general (heavy/light) cleaning, including sweeping, wash down, mopping, wiping of the construction facility and its furniture, washing, polishing, and dusting.

- **DELIVERY PERSONNEL**

- If delivery of supplies/building materials is to one common point and stockpiled there, prevailing wages are not required. If the delivery personnel are involved in the distribution of the material to multiple locations within the construction site then they would have to be paid prevailing wages for the type of work performed: laborer, equipment operator, electrician, ironworker, plumber, etc.

- An example of this would be where delivery of drywall is made to a building and the delivery personnel distribute the drywall from one "stockpile" location to further sub-locations on each floor. Distribution of material around a construction site is the job of a laborer or tradesman, and not a delivery personnel.

- **ELECTRICIANS**

Install, erect, maintenance, alteration or repair of any wire, cable, conduit, etc., which generates, transforms, transmits or uses electrical energy for light, heat, power or other purposes, including the Installation or maintenance of telecommunication, LAN wiring or computer equipment, and low voltage wiring. ****License required per Connecticut General Statutes: E-1,2 L-5,6 C-5,6 T-1,2 L-1,2 V-1,2,7,8,9.***

- **ELEVATOR CONSTRUCTORS**

Install, erect, maintenance and repair of all types of elevators, escalators, dumb waiters and moving walks. **License required by Connecticut General Statutes: R-1,2,5,6.*

- **FORK LIFT OPERATOR**

Laborers Group 4) Mason Tenders - operates forklift solely to assist a mason to a maximum height of nine (9) feet only.

Power Equipment Operator Group 9 - operates forklift to assist any trade, and to assist a mason to a height over nine (9) feet.

- **GLAZIERS**

Glazing wood and metal sash, doors, partitions, and 2 story aluminum storefronts. Installs glass windows, skylights, store fronts and display cases or surfaces such as building fronts, interior walls, ceilings and table tops and metal store fronts. Installation of aluminum window walls and curtain walls is the "joint" work of glaziers and ironworkers, which require equal composite workforce.

- **IRONWORKERS**

Erection, installation and placement of structural steel, precast concrete, miscellaneous iron, ornamental iron, metal curtain wall, rigging and reinforcing steel. Handling, sorting, and installation of reinforcing steel (rebar). Metal bridge rail (traffic), metal bridge handrail, and decorative security fence installation. Installation of aluminum window walls and curtain walls is the "joint" work of glaziers and ironworkers which require equal composite workforce.

- **INSULATOR**

- Installing fire stopping systems/materials for "Penetration Firestop Systems": transit to cables, electrical conduits, insulated pipes, sprinkler pipe penetrations, ductwork behind radiation, electrical cable trays, fire rated pipe penetrations, natural polypropylene, HVAC ducts, plumbing bare metal, telephone and communication wires, and boiler room ceilings.

- **LABORERS**

Acetylene burners, asphalt rakers, chain saw operators, concrete and power buggy operator, concrete saw operator, fence and guard rail erector (except metal bridge rail (traffic), decorative security fence (non-metal).

installation.), hand operated concrete vibrator operator, mason tenders, pipelayers (installation of storm drainage or sewage lines on the street only), pneumatic drill operator, pneumatic gas and electric drill operator, powermen and wagon drill operator, air track operator, block paver, curb setters, blasters, concrete spreaders.

- **PAINTERS**

Maintenance, preparation, cleaning, blasting (water and sand, etc.), painting or application of any protective coatings of every description on all bridges and appurtenances of highways, roadways, and railroads. Painting, decorating, hardwood finishing, paper hanging, sign writing, scenic art work and drywall hhg for any and all types of building and residential work.

- **LEAD PAINT REMOVAL**

- Painter's Rate

1. Removal of lead paint from bridges.
2. Removal of lead paint as preparation of any surface to be repainted.
3. Where removal is on a Demolition project prior to reconstruction.

- Laborer's Rate

1. Removal of lead paint from any surface NOT to be repainted.
2. Where removal is on a *TOTAL* Demolition project only.

- **PLUMBERS AND PIPEFITTERS**

Installation, repair, replacement, alteration or maintenance of all plumbing, heating, cooling and piping. ****License required per Connecticut General Statutes: P-1,2,6,7,8,9 J-1,2,3,4 SP-1,2 S-1,2,3,4,5,6,7,8 B-1,2,3,4 D-1,2,3,4.***

- **POWER EQUIPMENT OPERATORS**

Operates several types of power construction equipment such as compressors, pumps, hoists, derricks, cranes, shovels, tractors, scrapers or motor graders, etc. Repairs and maintains equipment. ****License required, crane operators only, per Connecticut General Statutes.***

- **ROOFERS**

Covers roofs with composition shingles or sheets, wood shingles, slate or asphalt and gravel to waterproof roofs, including preparation of surface. (demolition or removal of any type of roofing and or clean-up of any and all areas where a roof is to be relaid.)

- **SHEETMETAL WORKERS**

Fabricate, assembles, installs and repairs sheetmetal products and equipment in such areas as ventilation, air-conditioning, warm air heating, restaurant equipment, architectural sheet metal work, sheetmetal roofing, and aluminum gutters. Fabrication, handling, assembling, erecting, altering, repairing, etc. of coated metal material panels and composite metal material panels when used on building exteriors and interiors as soffits, fascia, louvers, partitions, canopies, cornice, column covers, awnings, beam covers, cladding, sun shades, lighting troughs, spires, ornamental roofing, metal ceilings, mansards, copings, ornamental and ventilation hoods, vertical and horizontal siding panels, trim, etc. The sheet metal classification also applies to the vast variety of coated metal material panels and composite metal material panels that have evolved over the years as an alternative to conventional ferrous and non-ferrous metals like steel, iron, tin, copper, brass, bronze, aluminum, etc. Fabrication, handling, assembling, erecting, altering, repairing, etc. of architectural metal roof, standing seam roof, composite metal roof, metal and composite bathroom/toilet partitions, aluminum gutters, metal and composite lockers and shelving, kitchen equipment, and walk-in coolers. To include testing and air –balancing ancillary to installation and construction.

- **SPRINKLER FITTERS**

Installation, alteration, maintenance and repair of fire protection sprinkler systems.

****License required per Connecticut General Statutes: F-1,2,3,4.***

- **TILE MARBLE AND TERRAZZO FINISHERS**

Assists and tends the tile setter, marble mason and terrazzo worker in the performance of their duties.

- **TRUCK DRIVERS**

~How to pay truck drivers delivering asphalt is under REVISION~

Truck Drivers are requires to be paid prevailing wage for time spent "working" directly on the site. These drivers remain covered by the prevailing wage for any time spent transporting between the actual construction location and facilities (such as fabrication, plants, mobile factories, batch plant, borrow pits, job headquarters, tool yards, etc.) dedicated exclusively, or nearly so, to performance of the contract or project, which are so located in proximity to the actual construction location that it is reasonable to include them. ****License required, drivers only, per Connecticut General Statutes.***

For example:

- Material men and deliverymen are not covered under prevailing wage as long as they are not directly involved in the construction process. If, they unload the material, they would then be covered by prevailing wage for the classification they are performing work in: laborer, equipment operator, etc.
- Hauling material off site is not covered provided they are not dumping it at a location outlined above.
- Driving a truck on site and moving equipment or materials on site would be considered covered work, as this is part of the construction process.

➤ *Any questions regarding the proper classification should be directed to:*
Public Contract Compliance Unit
Wage and Workplace Standards Division
Connecticut Department of Labor
200 Folly Brook Blvd, Wethersfield, CT 06109
(860) 263-6543.

**Connecticut Department of Labor
Wage and Workplace Standards Division
FOOTNOTES**

⇒ Please Note: If the “Benefits” listed on the schedule for the following occupations includes a letter(s) (+ a or + a+b for instance), refer to the information below.

Benefits to be paid at the appropriate prevailing wage rate for the listed occupation.

If the “Benefits” section for the occupation lists only a dollar amount, disregard the information below.

**Bricklayers, Cement Masons, Cement Finishers, Concrete Finishers, Stone Masons
(Building Construction) and
(Residential- Hartford, Middlesex, New Haven, New London and Tolland Counties)**

- a. Paid Holiday: Employees shall receive 4 hours for Christmas Eve holiday provided the employee works the regularly scheduled day before and after the holiday. Employers may schedule work on Christmas Eve and employees shall receive pay for actual hours worked in addition to holiday pay.

Elevator Constructors: Mechanics

- a. Paid Holidays: New Year’s Day, Memorial Day, Independence Day, Labor Day, Veterans’ Day, Thanksgiving Day, Christmas Day, plus the Friday after Thanksgiving.
- b. Vacation: Employer contributes 8% of basic hourly rate for 5 years or more of service or 6% of basic hourly rate for 6 months to 5 years of service as vacation pay credit.

Glaziers

- a. Paid Holidays: Labor Day and Christmas Day.

**Power Equipment Operators
(Heavy and Highway Construction & Building Construction)**

- a. Paid Holidays: New Year’s Day, Good Friday, Memorial day, Independence Day, Labor Day, Thanksgiving Day and Christmas Day, provided the employee works 3 days during the week in which the holiday falls, if scheduled, and if scheduled, the working day before and the working day after the holiday. Holidays falling on Saturday may be observed on Saturday, or if the employer so elects, on the preceding Friday.

Ironworkers

- a. Paid Holiday: Labor Day provided employee has been on the payroll for the 5 consecutive work days prior to Labor Day.

Laborers (Tunnel Construction)

- a. Paid Holidays: New Year's Day, Memorial Day, Independence Day, Labor Day, Thanksgiving Day and Christmas Day. No employee shall be eligible for holiday pay when he fails, without cause, to work the regular work day preceding the holiday or the regular work day following the holiday.

Roofers

- a. Paid Holidays: July 4th, Labor Day, and Christmas Day provided the employee is employed 15 days prior to the holiday.

Sprinkler Fitters

- a. Paid Holidays: Memorial Day, July 4th, Labor Day, Thanksgiving Day and Christmas Day, provided the employee has been in the employment of a contractor 20 working days prior to any such paid holiday.

Truck Drivers

(Heavy and Highway Construction & Building Construction)

- a. Paid Holidays: New Year's Day, Memorial Day, Independence Day, Labor Day, Thanksgiving Day, Christmas day, and Good Friday, provided the employee has at least 31 calendar days of service and works the last scheduled day before and the first scheduled day after the holiday, unless excused.

STANDARD FORM OF AGREEMENT
BETWEEN OWNER AND CONTRACTOR
ON THE BASIS OF A STIPULATED PRICE
B024-49 – WASHINGTON MIDDLE SCHOOL BOILER REPLACEMENT

THIS AGREEMENT is dated as of the _____ day of _____ 2024 by and between the City of Meriden, 142 East Main Street Meriden, CT 06450 hereinafter called OWNER and _____ hereinafter called CONTRACTOR.

OWNER and CONTRACTOR, in consideration of the mutual covenants hereinafter set forth, agree as follows:

Article 1. WORK.

CONTRACTOR shall complete all Work as specified or indicated in the Contract Documents. The Work is generally described as follows: Furnish labor and materials to replace the boiler at Washington Middle School, 1225 N Broad St, Meriden, CT 06450.

The Project for which the Work under the Contract Documents may be the whole or only a part is generally described as follows: Furnish labor and materials to replace the boiler at Washington Middle School, 1225 N Broad St, Meriden, CT 06450.

Article 2. ENGINEER.

The Project has been designed by Bemis Associates, LLC, 185 Main Street, Farmington, CT 06032 who is hereinafter called ENGINEER and who is to act as Owner's representative, assume all duties and responsibilities and has the rights and authority assigned to ENGINEER in the Contract Documents in connection with completion of the Work in accordance with the contract documents.

Article 3. CONTRACT TIMES.

3.1 The Work will be substantially completed by November 30, 2024, after the date when the Contract Times commence to run as provided in paragraph 2.03 of the General Conditions, and completed and ready for final payment in accordance with paragraph 14.07B of the General Conditions by November 30, 2024 after the date when the Contract Times commence to run.

3.2 Liquidated Damages. OWNER and CONTRACTOR recognize that time is of the essence of this Agreement and that OWNER will suffer financial loss if the Work is not completed within the times specified in paragraph 3.1 above, plus any extensions thereof allowed in accordance with Article 12 of the General Conditions. They also recognize the delays, expense and difficulties involved in proving the actual loss suffered by OWNER if the Work is not completed on time. Accordingly, instead of requiring any such proof, OWNER and CONTRACTOR agree that as liquidated damages for delay (but not as a penalty) CONTRACTOR shall pay OWNER Two Hundred Fifty Dollars (**\$250.00**) for each day that expires after the time specified in paragraph 3.1 for Substantial Completion until the Work is substantially complete. After Substantial Completion, if CONTRACTOR shall neglect, refuse or fail to complete the remaining Work within the time specified in paragraph 3.1 for completion and readiness for final payment or any proper extension thereof granted by OWNER, CONTRACTOR shall pay OWNER Two Hundred Fifty Dollars (**\$250.00**) for each day that expires after the time specified in paragraph 3.1 for completion and readiness for final payment.

Article 4. CONTRACT PRICE.

OWNER shall pay CONTRACTOR for completion of the Work in accordance with the Contract Documents an amount in current funds equal to the sum of the amounts determined pursuant to paragraphs 4.1 and 4.2 below:

4.1. For all Work, other than Unit Price Work, a Lump Sum of:

Figures

Written

All specific cash allowances are included in the above price and have been computed in accordance with 11.02 of the General Conditions;

Plus
4.2. For all Unit Price Work, an amount equal to the sum of the established unit price for each separately identified item of Unit Price Work times the estimated quantity of that item as indicated in this paragraph 4.2:

UNIT PRICE WORK – N/A

NO.	ITEM	UNIT	ESTIMATED QUANTITY	UNIT PRICE	TOTAL ESTIMATED
-----	------	------	--------------------	------------	-----------------

TOTAL OF ALL UNIT PRICES:

_____	\$ _____
Written	Figures

As provided in paragraph 11.03 of the General Conditions estimated quantities are not guaranteed, and determinations of actual quantities and classification are to be made by ENGINEER as provided in paragraph 9.07 of the General Conditions. Unit prices have been computed as provided in paragraph 11.03C of the General Conditions.

(The Bid may be attached. Any attachments and/or exhibits attached should be listed in Article 8).

If adjustment prices for variations from stipulated Base Bid quantities have been agreed to, insert appropriate provisions.

Article 5. PROGRESS PAYMENTS.

- 5.1 Based upon applications for Payment submitted to the Engineer by the Contractor and Certificates for Payment issued by the Engineer, the Owner shall make progress payments on account to the Contractor as provided below and elsewhere in the Contract Documents.
- 5.2 The period covered by each Application for Payment shall be one calendar month ending on the last day of the month.

- 5.3 Each Application for Payment shall be based upon the Schedule of Values submitted by the Contractor in accordance with the Contract Documents. The Schedule of Values shall allocate the entire Contract Sum among the various portions of the Work and be prepared in such form and supported by such data to substantiate its accuracy as the Engineer may require. This Schedule, unless objected to by the Engineer, shall be used as a basis for reviewing the Contractor's Applications for Payment.
- 5.4 Applications for Payment shall indicate the percentage of completion of each portion of the Work as of the end of the period covered by the Application for Payment.
- 5.5 Subject to the provisions of the Contract Documents, the amount of each progress payment shall be computed as follows:

5.6.1 Take that portion of the Contract sum properly allocable to completed work as determined by multiplying the percentage completion of each portion of the Work by the share of the total Contract Sum allocated to that portion of the work in the Schedule of Values, less retainage of five percent (5 percent). Pending final determination of cost to the Owner of changes in the Work, amounts not in dispute may be included as provided in appropriate sections of the General Conditions even though the Contract Sum has not yet been adjusted by Change Order.

5.6.2 Add that portion of the Contract Sum properly allocable to materials and equipment delivered and suitably stored at the site for subsequent incorporation in the completed construction (or, if approved in advance by the Owner, suitably stored off the site at a location agreed upon in writing) less retainage of five percent (5 percent).

5.6.3 Subtract the aggregate of previous payments made by the Owner; and

5.6.4 Subtract amounts, if any, for which the Engineer has withheld or nullified a Certificate for Payment as provided in Paragraph 14.02.B.5 of the General Conditions.

5.7 The progress payment amount determined in accordance with Paragraph 5.6 shall be further modified under the following circumstances;

(Not applicable)

5.7.1 Add, upon Substantial Completion of the Work, a sum sufficient to increase the total payments to ninety-five percent (95) of the Contract Sum, less such amounts as the Engineer shall determine for incomplete Work and unsettled claims; and

5.7.2 Add, if final completion of the Work is thereafter materially delayed, through no fault of the Contractor, additional amounts payable in accordance with Paragraph 14.08 of the General Conditions.

5.8 Reduction or limitation of retainage, if any shall be as follows:

(Not applicable)

Article 6. INTEREST.

No interest shall be due or paid on any monies not paid when due.

Article 7. CONTRACTOR'S REPRESENTATIONS.

In order to induce OWNER to enter into this Agreement CONTRACTOR makes the following representations:

7.1. CONTRACTOR has examined and carefully studied the Contract Documents including the Addenda listed in paragraph 8 and the other related data identified in the Bidding Documents including "technical data."

7.2. CONTRACTOR has visited the site and become familiar with and is satisfied as to the general, local and site conditions that may affect cost, progress, performance or furnishing of the Work.

7.3. CONTRACTOR is familiar with and is satisfied as to all federal, state and local Laws and Regulations that may affect cost, progress, performance and furnishing of the Work.

7.4. CONTRACTOR has carefully studied all reports of explorations and tests of subsurface conditions at or contiguous to the site and all drawings of physical conditions in or relating to existing surface or subsurface structures at or contiguous to the site (except Underground Facilities) which have been identified in the Supplementary Conditions as provided in paragraph 4.02 of the General Conditions. CONTRACTOR accepts the determination of the extent of the "technical data" contained in such reports and drawings upon which CONTRACTOR is entitled to rely. CONTRACTOR acknowledges that such reports and drawings are not Contract Documents and may not be complete for Contractor's purposes. CONTRACTOR acknowledges that OWNER and ENGINEER do not assume responsibility for the accuracy or completeness of information and data shown or indicated in the Contract Documents with respect to Underground Facilities at or contiguous to the site. CONTRACTOR has obtained and carefully studied assumes responsibility for having done so) all such additional supplementary examinations, investigations, explorations, tests, studies and data concerning conditions (surface, subsurface and Underground Facilities) at or contiguous to the site or otherwise which may affect cost, progress, performance or furnishing of the Work or which relate to any aspect of the means, methods, techniques, sequences and procedures of construction to be employed by CONTRACTOR and safety precautions and programs incident thereto. CONTRACTOR does not consider that any additional examinations, investigations, explorations, tests, studies or data are necessary for the performance and furnishing of the Work at the Contract Price, within the Contract Times and in accordance with the other terms and conditions of the contract Documents.

7.5. CONTRACTOR is aware of the general nature of work to be performed by OWNER and others at the site that relates to the Work as indicated in the Contract Documents.

7.6. CONTRACTOR has correlated the information known to CONTRACTOR, information and observation obtained from visits to the site, reports and drawings identified in the Contract Documents and all additional examinations, investigations, explorations, tests, studies and data with the Contract Documents.

7.7. CONTRACTOR has given ENGINEER written notice of all conflicts, errors, ambiguities or discrepancies that CONTRACTOR has discovered in the Contract Documents and the written resolution thereof by ENGINEER is acceptable to CONTRACTOR, and the Contract Documents are generally sufficient to indicate and convey understanding of all terms and conditions for performance and furnishing of the Work.

Article 8. CONTRACT DOCUMENTS.

The Contract Documents, which comprise the entire agreement between OWNER and CONTRACTOR concerning the Work, consist of the following:

8.1. This Agreement.

8.2. General Conditions and Supplemental General Conditions.

8.3. Notice of Award – **Attachment A**

8.4. Performance, Payment, and other Bonds – **Attachment B.**

8.5. Insurance certificate – **Attachment C**

8.6. Contractor's Bid Proposal, Non-Collusive Bid Statement, Bidder's Qualification Statement, St of CT Forms that are applicable - **Attachment D**

8.7. Connecticut Department of Labor – Wage and Workplace Standards Division.

8.8. **“By Reference”**: The complete Specifications as included in the bidding documents bearing the title.

8.9. **“By Reference”**: List of Drawings: Sheet No's. ___ through ___ included in the bidding documents.

The above documents are on file in the City of Meriden's Purchasing Department.

8.10. Addenda numbers ____.

(Those addenda which pertain exclusively to the bidding process need not be listed.)

8.11. The following which may be delivered or issued after the Effective Date of the Agreement and are not attached hereto: All-Written Amendments and other documents amending, modifying or supplementing the Contract Documents pursuant to paragraphs 3.04 and 3.05 of the General Conditions.

There are no Contract Documents other than those listed above. The Contract Documents may only be amended, modified or supplemented as provided in paragraphs 3.04 and 3.05 of the General Conditions.

Article 9. MISCELLANEOUS.

9.1. Terms used in this Agreement which are defined in Article I of the General Conditions will have the meanings indicated in the General Conditions.

9.2. No assignment by a party hereto of any rights under or interests in the Contract Documents will be binding on another party hereto without the written consent of the party sought to be bound; and, specifically but without limitation, moneys that may become due and moneys that are due may not be assigned without such consent (except to the extent that the effect of this restriction may be limited by law), and unless specifically stated to the contrary in any written consent to an assignment no assignment will release or discharge the assignor from any duty or responsibility under the Contract Documents.

9.3. OWNER and CONTRACTOR each binds itself, its partners, successors, assigns and legal representatives to the other party hereto, its partners, successors, assigns and legal representatives in respect to all covenants, agreements and obligations contained in the Contract Documents.

9.4. Any provision or part of the Contract Documents held to be void or unenforceable under any Law or Regulation shall be deemed stricken, and all remaining provisions shall continue to be valid and binding upon OWNER and CONTRACTOR, who agree that the Contract Documents shall be reformed to replace such stricken provision or part thereof with a valid and enforceable provision that comes as close as possible to expressing the intention of the stricken provision.

9.5 OTHER PROVISIONS – N/A

WITNESS WHEREOF, the parties hereto have affixed their names and seals.

THE CITY OF MERIDEN

CONTRACTOR:

Emily E. Holland City Manager Ag.
Duly Authorized

Duly Authorized

Date: _____

Date: _____

STANDARD GENERAL CONDITIONS OF THE CONSTRUCTION CONTRACT

Prepared by

ENGINEERS JOINT CONTRACT DOCUMENTS COMMITTEE

and

Issued and Published Jointly by



AMERICAN COUNCIL OF ENGINEERING COMPANIES

ASSOCIATED GENERAL CONTRACTORS OF AMERICA

AMERICAN SOCIETY OF CIVIL ENGINEERS

PROFESSIONAL ENGINEERS IN PRIVATE PRACTICE
A Practice Division of the
NATIONAL SOCIETY OF PROFESSIONAL ENGINEERS

Endorsed by



CONSTRUCTION SPECIFICATIONS INSTITUTE

Copyright © 2007 National Society of Professional Engineers
1420 King Street, Alexandria, VA 22314-2794
(703) 684-2882
www.nspe.org

American Council of Engineering Companies
1015 15th Street N.W., Washington, DC 20005
(202) 347-7474
www.acec.org

American Society of Civil Engineers
1801 Alexander Bell Drive, Reston, VA 20191-4400
(800) 548-2723
www.asce.org

Associated General Contractors of America
2300 Wilson Boulevard, Suite 400, Arlington, VA 22201-3308
(703) 548-3118
www.agc.org

The copyright for this EJCDC document is owned jointly by the four
EJCDC sponsoring organizations and held in trust for their benefit by NSPE.

STANDARD GENERAL CONDITIONS OF THE CONSTRUCTION CONTRACT

TABLE OF CONTENTS

	Page
Article 1 – Definitions and Terminology.....	1
1.01 Defined Terms	1
1.02 Terminology	5
Article 2 – Preliminary Matters.....	6
2.01 Delivery of Bonds and Evidence of Insurance.....	6
2.02 Copies of Documents	6
2.03 Commencement of Contract Times; Notice to Proceed.....	6
2.04 Starting the Work	7
2.05 Before Starting Construction.....	7
2.06 Preconstruction Conference; Designation of Authorized Representatives	7
2.07 Initial Acceptance of Schedules	7
Article 3 – Contract Documents: Intent, Amending, Reuse.....	8
3.01 Intent	8
3.02 Reference Standards	8
3.03 Reporting and Resolving Discrepancies	9
3.04 Amending and Supplementing Contract Documents	9
3.05 Reuse of Documents.....	10
3.06 Electronic Data	10
Article 4 – Availability of Lands; Subsurface and Physical Conditions; Hazardous Environmental Conditions; Reference Points	11
4.01 Availability of Lands	11
4.02 Subsurface and Physical Conditions	11
4.03 Differing Subsurface or Physical Conditions	12
4.04 Underground Facilities	13
4.05 Reference Points.....	14
4.06 Hazardous Environmental Condition at Site	14
Article 5 – Bonds and Insurance	16
5.01 Performance, Payment, and Other Bonds	16
5.02 Licensed Sureties and Insurers	16
5.03 Certificates of Insurance.....	17
5.04 Contractor’s Insurance.....	17
5.05 Owner’s Liability Insurance	19
5.06 Property Insurance	19
5.07 Waiver of Rights.....	20
5.08 Receipt and Application of Insurance Proceeds	21

5.09	Acceptance of Bonds and Insurance; Option to Replace.....	21
5.10	Partial Utilization, Acknowledgment of Property Insurer	22
Article 6 – Contractor’s Responsibilities		22
6.01	Supervision and Superintendence	22
6.02	Labor; Working Hours	22
6.03	Services, Materials, and Equipment.....	22
6.04	Progress Schedule.....	23
6.05	Substitutes and “Or-Equals”	23
6.06	Concerning Subcontractors, Suppliers, and Others	25
6.07	Patent Fees and Royalties.....	27
6.08	Permits	27
6.09	Laws and Regulations	28
6.10	Taxes.....	28
6.11	Use of Site and Other Areas	28
6.12	Record Documents	29
6.13	Safety and Protection.....	29
6.14	Safety Representative	30
6.15	Hazard Communication Programs.....	30
6.16	Emergencies.....	30
6.17	Shop Drawings and Samples.....	31
6.18	Continuing the Work.....	32
6.19	Contractor’s General Warranty and Guarantee.....	33
6.20	Indemnification.....	33
6.21	Delegation of Professional Design Services	34
Article 7 – Other Work at the Site		35
7.01	Related Work at Site.....	35
7.02	Coordination	35
7.03	Legal Relationships	36
Article 8 – Owner’s Responsibilities		36
8.01	Communications to Contractor	36
8.02	Replacement of Engineer	36
8.03	Furnish Data	36
8.04	Pay When Due	36
8.05	Lands and Easements; Reports and Tests	36
8.06	Insurance.....	36
8.07	Change Orders	37
8.08	Inspections, Tests, and Approvals.....	37
8.09	Limitations on Owner’s Responsibilities.....	37
8.10	Undisclosed Hazardous Environmental Condition	37
8.11	Evidence of Financial Arrangements.....	37
8.12	Compliance with Safety Program	37
Article 9 – Engineer’s Status During Construction		37
9.01	Owner’s Representative	37

9.02	Visits to Site.....	37
9.03	Project Representative.....	38
9.04	Authorized Variations in Work.....	38
9.05	Rejecting Defective Work.....	38
9.06	Shop Drawings, Change Orders and Payments.....	39
9.07	Determinations for Unit Price Work.....	39
9.08	Decisions on Requirements of Contract Documents and Acceptability of Work.....	39
9.09	Limitations on Engineer’s Authority and Responsibilities.....	39
9.10	Compliance with Safety Program.....	40
Article 10 – Changes in the Work; Claims.....		40
10.01	Authorized Changes in the Work.....	40
10.02	Unauthorized Changes in the Work.....	41
10.03	Execution of Change Orders.....	41
10.04	Notification to Surety.....	41
10.05	Claims.....	41
Article 11 – Cost of the Work; Allowances; Unit Price Work.....		42
11.01	Cost of the Work.....	42
11.02	Allowances.....	45
11.03	Unit Price Work.....	45
Article 12 – Change of Contract Price; Change of Contract Times.....		46
12.01	Change of Contract Price.....	46
12.02	Change of Contract Times.....	47
12.03	Delays.....	47
Article 13 – Tests and Inspections; Correction, Removal or Acceptance of Defective Work.....		48
13.01	Notice of Defects.....	48
13.02	Access to Work.....	48
13.03	Tests and Inspections.....	49
13.04	Uncovering Work.....	49
13.05	Owner May Stop the Work.....	50
13.06	Correction or Removal of Defective Work.....	50
13.07	Correction Period.....	50
13.08	Acceptance of Defective Work.....	51
13.09	Owner May Correct Defective Work.....	52
Article 14 – Payments to Contractor and Completion.....		52
14.01	Schedule of Values.....	52
14.02	Progress Payments.....	52
14.03	Contractor’s Warranty of Title.....	55
14.04	Substantial Completion.....	55
14.05	Partial Utilization.....	56
14.06	Final Inspection.....	57
14.07	Final Payment.....	57
14.08	Final Completion Delayed.....	58

14.09 Waiver of Claims.....	58
Article 15 – Suspension of Work and Termination.....	59
15.01 Owner May Suspend Work.....	59
15.02 Owner May Terminate for Cause.....	59
15.03 Owner May Terminate For Convenience	60
15.04 Contractor May Stop Work or Terminate.....	60
Article 16 – Dispute Resolution.....	61
16.01 Methods and Procedures	61
Article 17 – Miscellaneous	61
17.01 Giving Notice	61
17.02 Computation of Times.....	62
17.03 Cumulative Remedies	62
17.04 Survival of Obligations	62
17.05 Controlling Law.....	62
17.06 Headings	62

ARTICLE 1 – DEFINITIONS AND TERMINOLOGY

1.01 *Defined Terms*

- A. Wherever used in the Bidding Requirements or Contract Documents and printed with initial capital letters, the terms listed below will have the meanings indicated which are applicable to both the singular and plural thereof. In addition to terms specifically defined, terms with initial capital letters in the Contract Documents include references to identified articles and paragraphs, and the titles of other documents or forms.
1. *Addenda*—Written or graphic instruments issued prior to the opening of Bids which clarify, correct, or change the Bidding Requirements or the proposed Contract Documents.
 2. *Agreement*—The written instrument which is evidence of the agreement between Owner and Contractor covering the Work.
 3. *Application for Payment*—The form acceptable to Engineer which is to be used by Contractor during the course of the Work in requesting progress or final payments and which is to be accompanied by such supporting documentation as is required by the Contract Documents.
 4. *Asbestos*—Any material that contains more than one percent asbestos and is friable or is releasing asbestos fibers into the air above current action levels established by the United States Occupational Safety and Health Administration.
 5. *Bid*—The offer or proposal of a Bidder submitted on the prescribed form setting forth the prices for the Work to be performed.
 6. *Bidder*—The individual or entity who submits a Bid directly to Owner.
 7. *Bidding Documents*—The Bidding Requirements and the proposed Contract Documents (including all Addenda).
 8. *Bidding Requirements*—The advertisement or invitation to bid, Instructions to Bidders, Bid security of acceptable form, if any, and the Bid Form with any supplements.
 9. *Change Order*—A document recommended by Engineer which is signed by Contractor and Owner and authorizes an addition, deletion, or revision in the Work or an adjustment in the Contract Price or the Contract Times, issued on or after the Effective Date of the Agreement.
 10. *Claim*—A demand or assertion by Owner or Contractor seeking an adjustment of Contract Price or Contract Times, or both, or other relief with respect to the terms of the Contract. A demand for money or services by a third party is not a Claim.
 11. *Contract*—The entire and integrated written agreement between the Owner and Contractor concerning the Work. The Contract supersedes prior negotiations, representations, or agreements, whether written or oral.

12. *Contract Documents*—Those items so designated in the Agreement. Only printed or hard copies of the items listed in the Agreement are Contract Documents. Approved Shop Drawings, other Contractor submittals, and the reports and drawings of subsurface and physical conditions are not Contract Documents.
13. *Contract Price*—The moneys payable by Owner to Contractor for completion of the Work in accordance with the Contract Documents as stated in the Agreement (subject to the provisions of Paragraph 11.03 in the case of Unit Price Work).
14. *Contract Times*—The number of days or the dates stated in the Agreement to: (i) achieve Milestones, if any; (ii) achieve Substantial Completion; and (iii) complete the Work so that it is ready for final payment as evidenced by Engineer’s written recommendation of final payment.
15. *Contractor*—The individual or entity with whom Owner has entered into the Agreement.
16. *Cost of the Work*—See Paragraph 11.01 for definition.
17. *Drawings*—That part of the Contract Documents prepared or approved by Engineer which graphically shows the scope, extent, and character of the Work to be performed by Contractor. Shop Drawings and other Contractor submittals are not Drawings as so defined.
18. *Effective Date of the Agreement*—The date indicated in the Agreement on which it becomes effective, but if no such date is indicated, it means the date on which the Agreement is signed and delivered by the last of the two parties to sign and deliver.
19. *Engineer*—The individual or entity named as such in the Agreement.
20. *Field Order*—A written order issued by Engineer which requires minor changes in the Work but which does not involve a change in the Contract Price or the Contract Times.
21. *General Requirements*—Sections of Division 1 of the Specifications.
22. *Hazardous Environmental Condition*—The presence at the Site of Asbestos, PCBs, Petroleum, Hazardous Waste, or Radioactive Material in such quantities or circumstances that may present a substantial danger to persons or property exposed thereto.
23. *Hazardous Waste*—The term Hazardous Waste shall have the meaning provided in Section 1004 of the Solid Waste Disposal Act (42 USC Section 6903) as amended from time to time.
24. *Laws and Regulations; Laws or Regulations*—Any and all applicable laws, rules, regulations, ordinances, codes, and orders of any and all governmental bodies, agencies, authorities, and courts having jurisdiction.
25. *Liens*—Charges, security interests, or encumbrances upon Project funds, real property, or personal property.
26. *Milestone*—A principal event specified in the Contract Documents relating to an intermediate completion date or time prior to Substantial Completion of all the Work.

27. *Notice of Award*—The written notice by Owner to the Successful Bidder stating that upon timely compliance by the Successful Bidder with the conditions precedent listed therein, Owner will sign and deliver the Agreement.
28. *Notice to Proceed*—A written notice given by Owner to Contractor fixing the date on which the Contract Times will commence to run and on which Contractor shall start to perform the Work under the Contract Documents.
29. *Owner*—The individual or entity with whom Contractor has entered into the Agreement and for whom the Work is to be performed.
30. *PCBs*—Polychlorinated biphenyls.
31. *Petroleum*—Petroleum, including crude oil or any fraction thereof which is liquid at standard conditions of temperature and pressure (60 degrees Fahrenheit and 14.7 pounds per square inch absolute), such as oil, petroleum, fuel oil, oil sludge, oil refuse, gasoline, kerosene, and oil mixed with other non-Hazardous Waste and crude oils.
32. *Progress Schedule*—A schedule, prepared and maintained by Contractor, describing the sequence and duration of the activities comprising the Contractor's plan to accomplish the Work within the Contract Times.
33. *Project*—The total construction of which the Work to be performed under the Contract Documents may be the whole, or a part.
34. *Project Manual*—The bound documentary information prepared for bidding and constructing the Work. A listing of the contents of the Project Manual, which may be bound in one or more volumes, is contained in the table(s) of contents.
35. *Radioactive Material*—Source, special nuclear, or byproduct material as defined by the Atomic Energy Act of 1954 (42 USC Section 2011 et seq.) as amended from time to time.
36. *Resident Project Representative*—The authorized representative of Engineer who may be assigned to the Site or any part thereof.
37. *Samples*—Physical examples of materials, equipment, or workmanship that are representative of some portion of the Work and which establish the standards by which such portion of the Work will be judged.
38. *Schedule of Submittals*—A schedule, prepared and maintained by Contractor, of required submittals and the time requirements to support scheduled performance of related construction activities.
39. *Schedule of Values*—A schedule, prepared and maintained by Contractor, allocating portions of the Contract Price to various portions of the Work and used as the basis for reviewing Contractor's Applications for Payment.

40. *Shop Drawings*—All drawings, diagrams, illustrations, schedules, and other data or information which are specifically prepared or assembled by or for Contractor and submitted by Contractor to illustrate some portion of the Work.
41. *Site*—Lands or areas indicated in the Contract Documents as being furnished by Owner upon which the Work is to be performed, including rights-of-way and easements for access thereto, and such other lands furnished by Owner which are designated for the use of Contractor.
42. *Specifications*—That part of the Contract Documents consisting of written requirements for materials, equipment, systems, standards and workmanship as applied to the Work, and certain administrative requirements and procedural matters applicable thereto.
43. *Subcontractor*—An individual or entity having a direct contract with Contractor or with any other Subcontractor for the performance of a part of the Work at the Site.
44. *Substantial Completion*—The time at which the Work (or a specified part thereof) has progressed to the point where, in the opinion of Engineer, the Work (or a specified part thereof) is sufficiently complete, in accordance with the Contract Documents, so that the Work (or a specified part thereof) can be utilized for the purposes for which it is intended. The terms “substantially complete” and “substantially completed” as applied to all or part of the Work refer to Substantial Completion thereof.
45. *Successful Bidder*—The Bidder submitting a responsive Bid to whom Owner makes an award.
46. *Supplementary Conditions*—That part of the Contract Documents which amends or supplements these General Conditions.
47. *Supplier*—A manufacturer, fabricator, supplier, distributor, materialman, or vendor having a direct contract with Contractor or with any Subcontractor to furnish materials or equipment to be incorporated in the Work by Contractor or Subcontractor.
48. *Underground Facilities*—All underground pipelines, conduits, ducts, cables, wires, manholes, vaults, tanks, tunnels, or other such facilities or attachments, and any encasements containing such facilities, including those that convey electricity, gases, steam, liquid petroleum products, telephone or other communications, cable television, water, wastewater, storm water, other liquids or chemicals, or traffic or other control systems.
49. *Unit Price Work*—Work to be paid for on the basis of unit prices.
50. *Work*—The entire construction or the various separately identifiable parts thereof required to be provided under the Contract Documents. Work includes and is the result of performing or providing all labor, services, and documentation necessary to produce such construction, and furnishing, installing, and incorporating all materials and equipment into such construction, all as required by the Contract Documents.
51. *Work Change Directive*—A written statement to Contractor issued on or after the Effective Date of the Agreement and signed by Owner and recommended by Engineer ordering an

addition, deletion, or revision in the Work, or responding to differing or unforeseen subsurface or physical conditions under which the Work is to be performed or to emergencies. A Work Change Directive will not change the Contract Price or the Contract Times but is evidence that the parties expect that the change ordered or documented by a Work Change Directive will be incorporated in a subsequently issued Change Order following negotiations by the parties as to its effect, if any, on the Contract Price or Contract Times.

1.02 Terminology

A. The words and terms discussed in Paragraph 1.02.B through F are not defined but, when used in the Bidding Requirements or Contract Documents, have the indicated meaning.

B. *Intent of Certain Terms or Adjectives:*

1. The Contract Documents include the terms “as allowed,” “as approved,” “as ordered,” “as directed” or terms of like effect or import to authorize an exercise of professional judgment by Engineer. In addition, the adjectives “reasonable,” “suitable,” “acceptable,” “proper,” “satisfactory,” or adjectives of like effect or import are used to describe an action or determination of Engineer as to the Work. It is intended that such exercise of professional judgment, action, or determination will be solely to evaluate, in general, the Work for compliance with the information in the Contract Documents and with the design concept of the Project as a functioning whole as shown or indicated in the Contract Documents (unless there is a specific statement indicating otherwise). The use of any such term or adjective is not intended to and shall not be effective to assign to Engineer any duty or authority to supervise or direct the performance of the Work, or any duty or authority to undertake responsibility contrary to the provisions of Paragraph 9.09 or any other provision of the Contract Documents.

C. *Day:*

1. The word “day” means a calendar day of 24 hours measured from midnight to the next midnight.

D. *Defective:*

1. The word “defective,” when modifying the word “Work,” refers to Work that is unsatisfactory, faulty, or deficient in that it:
 - a. does not conform to the Contract Documents; or
 - b. does not meet the requirements of any applicable inspection, reference standard, test, or approval referred to in the Contract Documents; or
 - c. has been damaged prior to Engineer’s recommendation of final payment (unless responsibility for the protection thereof has been assumed by Owner at Substantial Completion in accordance with Paragraph 14.04 or 14.05).

E. *Furnish, Install, Perform, Provide:*

1. The word “furnish,” when used in connection with services, materials, or equipment, shall mean to supply and deliver said services, materials, or equipment to the Site (or some other specified location) ready for use or installation and in usable or operable condition.
2. The word “install,” when used in connection with services, materials, or equipment, shall mean to put into use or place in final position said services, materials, or equipment complete and ready for intended use.
3. The words “perform” or “provide,” when used in connection with services, materials, or equipment, shall mean to furnish and install said services, materials, or equipment complete and ready for intended use.
4. When “furnish,” “install,” “perform,” or “provide” is not used in connection with services, materials, or equipment in a context clearly requiring an obligation of Contractor, “provide” is implied.

F. Unless stated otherwise in the Contract Documents, words or phrases that have a well-known technical or construction industry or trade meaning are used in the Contract Documents in accordance with such recognized meaning.

ARTICLE 2 – PRELIMINARY MATTERS

2.01 Delivery of Bonds and Evidence of Insurance

- A. When Contractor delivers the executed counterparts of the Agreement to Owner, Contractor shall also deliver to Owner such bonds as Contractor may be required to furnish.
- B. *Evidence of Insurance:* Before any Work at the Site is started, Contractor and Owner shall each deliver to the other, with copies to each additional insured identified in the Supplementary Conditions, certificates of insurance (and other evidence of insurance which either of them or any additional insured may reasonably request) which Contractor and Owner respectively are required to purchase and maintain in accordance with Article 5.

2.02 Copies of Documents

- A. Owner shall furnish to Contractor up to ten printed or hard copies of the Drawings and Project Manual. Additional copies will be furnished upon request at the cost of reproduction.

2.03 Commencement of Contract Times; Notice to Proceed

- A. The Contract Times will commence to run on the thirtieth day after the Effective Date of the Agreement or, if a Notice to Proceed is given, on the day indicated in the Notice to Proceed. A Notice to Proceed may be given at any time within 30 days after the Effective Date of the Agreement. In no event will the Contract Times commence to run later than the sixtieth day after the day of Bid opening or the thirtieth day after the Effective Date of the Agreement, whichever date is earlier.

2.04 *Starting the Work*

- A. Contractor shall start to perform the Work on the date when the Contract Times commence to run. No Work shall be done at the Site prior to the date on which the Contract Times commence to run.

2.05 *Before Starting Construction*

- A. *Preliminary Schedules:* Within 10 days after the Effective Date of the Agreement (unless otherwise specified in the General Requirements), Contractor shall submit to Engineer for timely review:
 - 1. a preliminary Progress Schedule indicating the times (numbers of days or dates) for starting and completing the various stages of the Work, including any Milestones specified in the Contract Documents;
 - 2. a preliminary Schedule of Submittals; and
 - 3. a preliminary Schedule of Values for all of the Work which includes quantities and prices of items which when added together equal the Contract Price and subdivides the Work into component parts in sufficient detail to serve as the basis for progress payments during performance of the Work. Such prices will include an appropriate amount of overhead and profit applicable to each item of Work.

2.06 *Preconstruction Conference; Designation of Authorized Representatives*

- A. Before any Work at the Site is started, a conference attended by Owner, Contractor, Engineer, and others as appropriate will be held to establish a working understanding among the parties as to the Work and to discuss the schedules referred to in Paragraph 2.05.A, procedures for handling Shop Drawings and other submittals, processing Applications for Payment, and maintaining required records.
- B. At this conference Owner and Contractor each shall designate, in writing, a specific individual to act as its authorized representative with respect to the services and responsibilities under the Contract. Such individuals shall have the authority to transmit instructions, receive information, render decisions relative to the Contract, and otherwise act on behalf of each respective party.

2.07 *Initial Acceptance of Schedules*

- A. At least 10 days before submission of the first Application for Payment a conference attended by Contractor, Engineer, and others as appropriate will be held to review for acceptability to Engineer as provided below the schedules submitted in accordance with Paragraph 2.05.A. Contractor shall have an additional 10 days to make corrections and adjustments and to complete and resubmit the schedules. No progress payment shall be made to Contractor until acceptable schedules are submitted to Engineer.
 - 1. The Progress Schedule will be acceptable to Engineer if it provides an orderly progression of the Work to completion within the Contract Times. Such acceptance will not impose on

Engineer responsibility for the Progress Schedule, for sequencing, scheduling, or progress of the Work, nor interfere with or relieve Contractor from Contractor's full responsibility therefor.

2. Contractor's Schedule of Submittals will be acceptable to Engineer if it provides a workable arrangement for reviewing and processing the required submittals.
3. Contractor's Schedule of Values will be acceptable to Engineer as to form and substance if it provides a reasonable allocation of the Contract Price to component parts of the Work.

ARTICLE 3 – CONTRACT DOCUMENTS: INTENT, AMENDING, REUSE

3.01 *Intent*

- A. The Contract Documents are complementary; what is required by one is as binding as if required by all.
- B. It is the intent of the Contract Documents to describe a functionally complete project (or part thereof) to be constructed in accordance with the Contract Documents. Any labor, documentation, services, materials, or equipment that reasonably may be inferred from the Contract Documents or from prevailing custom or trade usage as being required to produce the indicated result will be provided whether or not specifically called for, at no additional cost to Owner.
- C. Clarifications and interpretations of the Contract Documents shall be issued by Engineer as provided in Article 9.

3.02 *Reference Standards*

- A. Standards, Specifications, Codes, Laws, and Regulations
 1. Reference to standards, specifications, manuals, or codes of any technical society, organization, or association, or to Laws or Regulations, whether such reference be specific or by implication, shall mean the standard, specification, manual, code, or Laws or Regulations in effect at the time of opening of Bids (or on the Effective Date of the Agreement if there were no Bids), except as may be otherwise specifically stated in the Contract Documents.
 2. No provision of any such standard, specification, manual, or code, or any instruction of a Supplier, shall be effective to change the duties or responsibilities of Owner, Contractor, or Engineer, or any of their subcontractors, consultants, agents, or employees, from those set forth in the Contract Documents. No such provision or instruction shall be effective to assign to Owner, Engineer, or any of their officers, directors, members, partners, employees, agents, consultants, or subcontractors, any duty or authority to supervise or direct the performance of the Work or any duty or authority to undertake responsibility inconsistent with the provisions of the Contract Documents.

3.03 *Reporting and Resolving Discrepancies*

A. *Reporting Discrepancies:*

1. *Contractor's Review of Contract Documents Before Starting Work:* Before undertaking each part of the Work, Contractor shall carefully study and compare the Contract Documents and check and verify pertinent figures therein and all applicable field measurements. Contractor shall promptly report in writing to Engineer any conflict, error, ambiguity, or discrepancy which Contractor discovers, or has actual knowledge of, and shall obtain a written interpretation or clarification from Engineer before proceeding with any Work affected thereby.
2. *Contractor's Review of Contract Documents During Performance of Work:* If, during the performance of the Work, Contractor discovers any conflict, error, ambiguity, or discrepancy within the Contract Documents, or between the Contract Documents and (a) any applicable Law or Regulation, (b) any standard, specification, manual, or code, or (c) any instruction of any Supplier, then Contractor shall promptly report it to Engineer in writing. Contractor shall not proceed with the Work affected thereby (except in an emergency as required by Paragraph 6.16.A) until an amendment or supplement to the Contract Documents has been issued by one of the methods indicated in Paragraph 3.04.
3. Contractor shall not be liable to Owner or Engineer for failure to report any conflict, error, ambiguity, or discrepancy in the Contract Documents unless Contractor had actual knowledge thereof.

B. *Resolving Discrepancies:*

1. Except as may be otherwise specifically stated in the Contract Documents, the provisions of the Contract Documents shall take precedence in resolving any conflict, error, ambiguity, or discrepancy between the provisions of the Contract Documents and:
 - a. the provisions of any standard, specification, manual, or code, or the instruction of any Supplier (whether or not specifically incorporated by reference in the Contract Documents); or
 - b. the provisions of any Laws or Regulations applicable to the performance of the Work (unless such an interpretation of the provisions of the Contract Documents would result in violation of such Law or Regulation).

3.04 *Amending and Supplementing Contract Documents*

- A. The Contract Documents may be amended to provide for additions, deletions, and revisions in the Work or to modify the terms and conditions thereof by either a Change Order or a Work Change Directive.
- B. The requirements of the Contract Documents may be supplemented, and minor variations and deviations in the Work may be authorized, by one or more of the following ways:

1. A Field Order;
2. Engineer's approval of a Shop Drawing or Sample (subject to the provisions of Paragraph 6.17.D.3); or
3. Engineer's written interpretation or clarification.

3.05 *Reuse of Documents*

A. Contractor and any Subcontractor or Supplier shall not:

1. have or acquire any title to or ownership rights in any of the Drawings, Specifications, or other documents (or copies of any thereof) prepared by or bearing the seal of Engineer or its consultants, including electronic media editions; or
2. reuse any such Drawings, Specifications, other documents, or copies thereof on extensions of the Project or any other project without written consent of Owner and Engineer and specific written verification or adaptation by Engineer.

B. The prohibitions of this Paragraph 3.05 will survive final payment, or termination of the Contract. Nothing herein shall preclude Contractor from retaining copies of the Contract Documents for record purposes.

3.06 *Electronic Data*

A. Unless otherwise stated in the Supplementary Conditions, the data furnished by Owner or Engineer to Contractor, or by Contractor to Owner or Engineer, that may be relied upon are limited to the printed copies (also known as hard copies). Files in electronic media format of text, data, graphics, or other types are furnished only for the convenience of the receiving party. Any conclusion or information obtained or derived from such electronic files will be at the user's sole risk. If there is a discrepancy between the electronic files and the hard copies, the hard copies govern.

B. Because data stored in electronic media format can deteriorate or be modified inadvertently or otherwise without authorization of the data's creator, the party receiving electronic files agrees that it will perform acceptance tests or procedures within 60 days, after which the receiving party shall be deemed to have accepted the data thus transferred. Any errors detected within the 60-day acceptance period will be corrected by the transferring party.

C. When transferring documents in electronic media format, the transferring party makes no representations as to long term compatibility, usability, or readability of documents resulting from the use of software application packages, operating systems, or computer hardware differing from those used by the data's creator.

**ARTICLE 4 – AVAILABILITY OF LANDS; SUBSURFACE AND PHYSICAL CONDITIONS;
HAZARDOUS ENVIRONMENTAL CONDITIONS; REFERENCE POINTS**

4.01 *Availability of Lands*

- A. Owner shall furnish the Site. Owner shall notify Contractor of any encumbrances or restrictions not of general application but specifically related to use of the Site with which Contractor must comply in performing the Work. Owner will obtain in a timely manner and pay for easements for permanent structures or permanent changes in existing facilities. If Contractor and Owner are unable to agree on entitlement to or on the amount or extent, if any, of any adjustment in the Contract Price or Contract Times, or both, as a result of any delay in Owner’s furnishing the Site or a part thereof, Contractor may make a Claim therefor as provided in Paragraph 10.05.
- B. Upon reasonable written request, Owner shall furnish Contractor with a current statement of record legal title and legal description of the lands upon which the Work is to be performed and Owner’s interest therein as necessary for giving notice of or filing a mechanic’s or construction lien against such lands in accordance with applicable Laws and Regulations.
- C. Contractor shall provide for all additional lands and access thereto that may be required for temporary construction facilities or storage of materials and equipment.

4.02 *Subsurface and Physical Conditions*

- A. *Reports and Drawings:* The Supplementary Conditions identify:
 - 1. those reports known to Owner of explorations and tests of subsurface conditions at or contiguous to the Site; and
 - 2. those drawings known to Owner of physical conditions relating to existing surface or subsurface structures at the Site (except Underground Facilities).
- B. *Limited Reliance by Contractor on Technical Data Authorized:* Contractor may rely upon the accuracy of the “technical data” contained in such reports and drawings, but such reports and drawings are not Contract Documents. Such “technical data” is identified in the Supplementary Conditions. Except for such reliance on such “technical data,” Contractor may not rely upon or make any claim against Owner or Engineer, or any of their officers, directors, members, partners, employees, agents, consultants, or subcontractors with respect to:
 - 1. the completeness of such reports and drawings for Contractor’s purposes, including, but not limited to, any aspects of the means, methods, techniques, sequences, and procedures of construction to be employed by Contractor, and safety precautions and programs incident thereto; or
 - 2. other data, interpretations, opinions, and information contained in such reports or shown or indicated in such drawings; or
 - 3. any Contractor interpretation of or conclusion drawn from any “technical data” or any such other data, interpretations, opinions, or information.

4.03 *Differing Subsurface or Physical Conditions*

A. *Notice:* If Contractor believes that any subsurface or physical condition that is uncovered or revealed either:

1. is of such a nature as to establish that any “technical data” on which Contractor is entitled to rely as provided in Paragraph 4.02 is materially inaccurate; or
2. is of such a nature as to require a change in the Contract Documents; or
3. differs materially from that shown or indicated in the Contract Documents; or
4. is of an unusual nature, and differs materially from conditions ordinarily encountered and generally recognized as inherent in work of the character provided for in the Contract Documents;

then Contractor shall, promptly after becoming aware thereof and before further disturbing the subsurface or physical conditions or performing any Work in connection therewith (except in an emergency as required by Paragraph 6.16.A), notify Owner and Engineer in writing about such condition. Contractor shall not further disturb such condition or perform any Work in connection therewith (except as aforesaid) until receipt of written order to do so.

B. *Engineer’s Review:* After receipt of written notice as required by Paragraph 4.03.A, Engineer will promptly review the pertinent condition, determine the necessity of Owner’s obtaining additional exploration or tests with respect thereto, and advise Owner in writing (with a copy to Contractor) of Engineer’s findings and conclusions.

C. *Possible Price and Times Adjustments:*

1. The Contract Price or the Contract Times, or both, will be equitably adjusted to the extent that the existence of such differing subsurface or physical condition causes an increase or decrease in Contractor’s cost of, or time required for, performance of the Work; subject, however, to the following:
 - a. such condition must meet any one or more of the categories described in Paragraph 4.03.A; and
 - b. with respect to Work that is paid for on a unit price basis, any adjustment in Contract Price will be subject to the provisions of Paragraphs 9.07 and 11.03.
2. Contractor shall not be entitled to any adjustment in the Contract Price or Contract Times if:
 - a. Contractor knew of the existence of such conditions at the time Contractor made a final commitment to Owner with respect to Contract Price and Contract Times by the submission of a Bid or becoming bound under a negotiated contract; or
 - b. the existence of such condition could reasonably have been discovered or revealed as a result of any examination, investigation, exploration, test, or study of the Site and

contiguous areas required by the Bidding Requirements or Contract Documents to be conducted by or for Contractor prior to Contractor's making such final commitment; or

c. Contractor failed to give the written notice as required by Paragraph 4.03.A.

3. If Owner and Contractor are unable to agree on entitlement to or on the amount or extent, if any, of any adjustment in the Contract Price or Contract Times, or both, a Claim may be made therefor as provided in Paragraph 10.05. However, neither Owner or Engineer, or any of their officers, directors, members, partners, employees, agents, consultants, or subcontractors shall be liable to Contractor for any claims, costs, losses, or damages (including but not limited to all fees and charges of engineers, architects, attorneys, and other professionals and all court or arbitration or other dispute resolution costs) sustained by Contractor on or in connection with any other project or anticipated project.

4.04 *Underground Facilities*

A. *Shown or Indicated:* The information and data shown or indicated in the Contract Documents with respect to existing Underground Facilities at or contiguous to the Site is based on information and data furnished to Owner or Engineer by the owners of such Underground Facilities, including Owner, or by others. Unless it is otherwise expressly provided in the Supplementary Conditions:

1. Owner and Engineer shall not be responsible for the accuracy or completeness of any such information or data provided by others; and
2. the cost of all of the following will be included in the Contract Price, and Contractor shall have full responsibility for:
 - a. reviewing and checking all such information and data;
 - b. locating all Underground Facilities shown or indicated in the Contract Documents;
 - c. coordination of the Work with the owners of such Underground Facilities, including Owner, during construction; and
 - d. the safety and protection of all such Underground Facilities and repairing any damage thereto resulting from the Work.

B. *Not Shown or Indicated:*

1. If an Underground Facility is uncovered or revealed at or contiguous to the Site which was not shown or indicated, or not shown or indicated with reasonable accuracy in the Contract Documents, Contractor shall, promptly after becoming aware thereof and before further disturbing conditions affected thereby or performing any Work in connection therewith (except in an emergency as required by Paragraph 6.16.A), identify the owner of such Underground Facility and give written notice to that owner and to Owner and Engineer. Engineer will promptly review the Underground Facility and determine the extent, if any, to which a change is required in the Contract Documents to reflect and document the

consequences of the existence or location of the Underground Facility. During such time, Contractor shall be responsible for the safety and protection of such Underground Facility.

2. If Engineer concludes that a change in the Contract Documents is required, a Work Change Directive or a Change Order will be issued to reflect and document such consequences. An equitable adjustment shall be made in the Contract Price or Contract Times, or both, to the extent that they are attributable to the existence or location of any Underground Facility that was not shown or indicated or not shown or indicated with reasonable accuracy in the Contract Documents and that Contractor did not know of and could not reasonably have been expected to be aware of or to have anticipated. If Owner and Contractor are unable to agree on entitlement to or on the amount or extent, if any, of any such adjustment in Contract Price or Contract Times, Owner or Contractor may make a Claim therefor as provided in Paragraph 10.05.

4.05 *Reference Points*

- A. Owner shall provide engineering surveys to establish reference points for construction which in Engineer's judgment are necessary to enable Contractor to proceed with the Work. Contractor shall be responsible for laying out the Work, shall protect and preserve the established reference points and property monuments, and shall make no changes or relocations without the prior written approval of Owner. Contractor shall report to Engineer whenever any reference point or property monument is lost or destroyed or requires relocation because of necessary changes in grades or locations, and shall be responsible for the accurate replacement or relocation of such reference points or property monuments by professionally qualified personnel.

4.06 *Hazardous Environmental Condition at Site*

- A. *Reports and Drawings:* The Supplementary Conditions identify those reports and drawings known to Owner relating to Hazardous Environmental Conditions that have been identified at the Site.
- B. *Limited Reliance by Contractor on Technical Data Authorized:* Contractor may rely upon the accuracy of the "technical data" contained in such reports and drawings, but such reports and drawings are not Contract Documents. Such "technical data" is identified in the Supplementary Conditions. Except for such reliance on such "technical data," Contractor may not rely upon or make any claim against Owner or Engineer, or any of their officers, directors, members, partners, employees, agents, consultants, or subcontractors with respect to:
 1. the completeness of such reports and drawings for Contractor's purposes, including, but not limited to, any aspects of the means, methods, techniques, sequences and procedures of construction to be employed by Contractor and safety precautions and programs incident thereto; or
 2. other data, interpretations, opinions and information contained in such reports or shown or indicated in such drawings; or
 3. any Contractor interpretation of or conclusion drawn from any "technical data" or any such other data, interpretations, opinions or information.

- C. Contractor shall not be responsible for any Hazardous Environmental Condition uncovered or revealed at the Site which was not shown or indicated in Drawings or Specifications or identified in the Contract Documents to be within the scope of the Work. Contractor shall be responsible for a Hazardous Environmental Condition created with any materials brought to the Site by Contractor, Subcontractors, Suppliers, or anyone else for whom Contractor is responsible.
- D. If Contractor encounters a Hazardous Environmental Condition or if Contractor or anyone for whom Contractor is responsible creates a Hazardous Environmental Condition, Contractor shall immediately: (i) secure or otherwise isolate such condition; (ii) stop all Work in connection with such condition and in any area affected thereby (except in an emergency as required by Paragraph 6.16.A); and (iii) notify Owner and Engineer (and promptly thereafter confirm such notice in writing). Owner shall promptly consult with Engineer concerning the necessity for Owner to retain a qualified expert to evaluate such condition or take corrective action, if any. Promptly after consulting with Engineer, Owner shall take such actions as are necessary to permit Owner to timely obtain required permits and provide Contractor the written notice required by Paragraph 4.06.E.
- E. Contractor shall not be required to resume Work in connection with such condition or in any affected area until after Owner has obtained any required permits related thereto and delivered written notice to Contractor: (i) specifying that such condition and any affected area is or has been rendered safe for the resumption of Work; or (ii) specifying any special conditions under which such Work may be resumed safely. If Owner and Contractor cannot agree as to entitlement to or on the amount or extent, if any, of any adjustment in Contract Price or Contract Times, or both, as a result of such Work stoppage or such special conditions under which Work is agreed to be resumed by Contractor, either party may make a Claim therefor as provided in Paragraph 10.05.
- F. If after receipt of such written notice Contractor does not agree to resume such Work based on a reasonable belief it is unsafe, or does not agree to resume such Work under such special conditions, then Owner may order the portion of the Work that is in the area affected by such condition to be deleted from the Work. If Owner and Contractor cannot agree as to entitlement to or on the amount or extent, if any, of an adjustment in Contract Price or Contract Times as a result of deleting such portion of the Work, then either party may make a Claim therefor as provided in Paragraph 10.05. Owner may have such deleted portion of the Work performed by Owner's own forces or others in accordance with Article 7.
- G. To the fullest extent permitted by Laws and Regulations, Owner shall indemnify and hold harmless Contractor, Subcontractors, and Engineer, and the officers, directors, members, partners, employees, agents, consultants, and subcontractors of each and any of them from and against all claims, costs, losses, and damages (including but not limited to all fees and charges of engineers, architects, attorneys, and other professionals and all court or arbitration or other dispute resolution costs) arising out of or relating to a Hazardous Environmental Condition, provided that such Hazardous Environmental Condition: (i) was not shown or indicated in the Drawings or Specifications or identified in the Contract Documents to be included within the scope of the Work, and (ii) was not created by Contractor or by anyone for whom Contractor is responsible. Nothing in this Paragraph 4.06.G shall obligate Owner to indemnify any individual or entity from and against the consequences of that individual's or entity's own negligence.

- H. To the fullest extent permitted by Laws and Regulations, Contractor shall indemnify and hold harmless Owner and Engineer, and the officers, directors, members, partners, employees, agents, consultants, and subcontractors of each and any of them from and against all claims, costs, losses, and damages (including but not limited to all fees and charges of engineers, architects, attorneys, and other professionals and all court or arbitration or other dispute resolution costs) arising out of or relating to a Hazardous Environmental Condition created by Contractor or by anyone for whom Contractor is responsible. Nothing in this Paragraph 4.06.H shall obligate Contractor to indemnify any individual or entity from and against the consequences of that individual's or entity's own negligence.
- I. The provisions of Paragraphs 4.02, 4.03, and 4.04 do not apply to a Hazardous Environmental Condition uncovered or revealed at the Site.

ARTICLE 5 – BONDS AND INSURANCE

5.01 *Performance, Payment, and Other Bonds*

- A. Contractor shall furnish performance and payment bonds, each in an amount at least equal to the Contract Price as security for the faithful performance and payment of all of Contractor's obligations under the Contract Documents. These bonds shall remain in effect until one year after the date when final payment becomes due or until completion of the correction period specified in Paragraph 13.07, whichever is later, except as provided otherwise by Laws or Regulations or by the Contract Documents. Contractor shall also furnish such other bonds as are required by the Contract Documents.
- B. All bonds shall be in the form prescribed by the Contract Documents except as provided otherwise by Laws or Regulations, and shall be executed by such sureties as are named in the list of "Companies Holding Certificates of Authority as Acceptable Sureties on Federal Bonds and as Acceptable Reinsuring Companies" as published in Circular 570 (amended) by the Financial Management Service, Surety Bond Branch, U.S. Department of the Treasury. All bonds signed by an agent or attorney-in-fact must be accompanied by a certified copy of that individual's authority to bind the surety. The evidence of authority shall show that it is effective on the date the agent or attorney-in-fact signed each bond.
- C. If the surety on any bond furnished by Contractor is declared bankrupt or becomes insolvent or its right to do business is terminated in any state where any part of the Project is located or it ceases to meet the requirements of Paragraph 5.01.B, Contractor shall promptly notify Owner and Engineer and shall, within 20 days after the event giving rise to such notification, provide another bond and surety, both of which shall comply with the requirements of Paragraphs 5.01.B and 5.02.

5.02 *Licensed Sureties and Insurers*

- A. All bonds and insurance required by the Contract Documents to be purchased and maintained by Owner or Contractor shall be obtained from surety or insurance companies that are duly licensed or authorized in the jurisdiction in which the Project is located to issue bonds or insurance policies for the limits and coverages so required. Such surety and insurance companies shall also

meet such additional requirements and qualifications as may be provided in the Supplementary Conditions.

5.03 *Certificates of Insurance*

- A. Contractor shall deliver to Owner, with copies to each additional insured and loss payee identified in the Supplementary Conditions, certificates of insurance (and other evidence of insurance requested by Owner or any other additional insured) which Contractor is required to purchase and maintain.
- B. Owner shall deliver to Contractor, with copies to each additional insured and loss payee identified in the Supplementary Conditions, certificates of insurance (and other evidence of insurance requested by Contractor or any other additional insured) which Owner is required to purchase and maintain.
- C. Failure of Owner to demand such certificates or other evidence of Contractor's full compliance with these insurance requirements or failure of Owner to identify a deficiency in compliance from the evidence provided shall not be construed as a waiver of Contractor's obligation to maintain such insurance.
- D. Owner does not represent that insurance coverage and limits established in this Contract necessarily will be adequate to protect Contractor.
- E. The insurance and insurance limits required herein shall not be deemed as a limitation on Contractor's liability under the indemnities granted to Owner in the Contract Documents.

5.04 *Contractor's Insurance*

- A. Contractor shall purchase and maintain such insurance as is appropriate for the Work being performed and as will provide protection from claims set forth below which may arise out of or result from Contractor's performance of the Work and Contractor's other obligations under the Contract Documents, whether it is to be performed by Contractor, any Subcontractor or Supplier, or by anyone directly or indirectly employed by any of them to perform any of the Work, or by anyone for whose acts any of them may be liable:
 - 1. claims under workers' compensation, disability benefits, and other similar employee benefit acts;
 - 2. claims for damages because of bodily injury, occupational sickness or disease, or death of Contractor's employees;
 - 3. claims for damages because of bodily injury, sickness or disease, or death of any person other than Contractor's employees;
 - 4. claims for damages insured by reasonably available personal injury liability coverage which are sustained:

- a. by any person as a result of an offense directly or indirectly related to the employment of such person by Contractor, or
 - b. by any other person for any other reason;
5. claims for damages, other than to the Work itself, because of injury to or destruction of tangible property wherever located, including loss of use resulting therefrom; and
 6. claims for damages because of bodily injury or death of any person or property damage arising out of the ownership, maintenance or use of any motor vehicle.
- B. The policies of insurance required by this Paragraph 5.04 shall:
1. with respect to insurance required by Paragraphs 5.04.A.3 through 5.04.A.6 inclusive, be written on an occurrence basis, include as additional insureds (subject to any customary exclusion regarding professional liability) Owner and Engineer, and any other individuals or entities identified in the Supplementary Conditions, all of whom shall be listed as additional insureds, and include coverage for the respective officers, directors, members, partners, employees, agents, consultants, and subcontractors of each and any of all such additional insureds, and the insurance afforded to these additional insureds shall provide primary coverage for all claims covered thereby;
 2. include at least the specific coverages and be written for not less than the limits of liability provided in the Supplementary Conditions or required by Laws or Regulations, whichever is greater;
 3. include contractual liability insurance covering Contractor's indemnity obligations under Paragraphs 6.11 and 6.20;
 4. contain a provision or endorsement that the coverage afforded will not be canceled, materially changed or renewal refused until at least 30 days prior written notice has been given to Owner and Contractor and to each other additional insured identified in the Supplementary Conditions to whom a certificate of insurance has been issued (and the certificates of insurance furnished by the Contractor pursuant to Paragraph 5.03 will so provide);
 5. remain in effect at least until final payment and at all times thereafter when Contractor may be correcting, removing, or replacing defective Work in accordance with Paragraph 13.07; and
 6. include completed operations coverage:
 - a. Such insurance shall remain in effect for two years after final payment.
 - b. Contractor shall furnish Owner and each other additional insured identified in the Supplementary Conditions, to whom a certificate of insurance has been issued, evidence satisfactory to Owner and any such additional insured of continuation of such insurance at final payment and one year thereafter.

5.05 *Owner's Liability Insurance*

- A. In addition to the insurance required to be provided by Contractor under Paragraph 5.04, Owner, at Owner's option, may purchase and maintain at Owner's expense Owner's own liability insurance as will protect Owner against claims which may arise from operations under the Contract Documents.

5.06 *Property Insurance*

- A. Unless otherwise provided in the Supplementary Conditions, Owner shall purchase and maintain property insurance upon the Work at the Site in the amount of the full replacement cost thereof (subject to such deductible amounts as may be provided in the Supplementary Conditions or required by Laws and Regulations). This insurance shall:
1. include the interests of Owner, Contractor, Subcontractors, and Engineer, and any other individuals or entities identified in the Supplementary Conditions, and the officers, directors, members, partners, employees, agents, consultants, and subcontractors of each and any of them, each of whom is deemed to have an insurable interest and shall be listed as a loss payee;
 2. be written on a Builder's Risk "all-risk" policy form that shall at least include insurance for physical loss or damage to the Work, temporary buildings, falsework, and materials and equipment in transit, and shall insure against at least the following perils or causes of loss: fire, lightning, extended coverage, theft, vandalism and malicious mischief, earthquake, collapse, debris removal, demolition occasioned by enforcement of Laws and Regulations, water damage (other than that caused by flood), and such other perils or causes of loss as may be specifically required by the Supplementary Conditions.
 3. include expenses incurred in the repair or replacement of any insured property (including but not limited to fees and charges of engineers and architects);
 4. cover materials and equipment stored at the Site or at another location that was agreed to in writing by Owner prior to being incorporated in the Work, provided that such materials and equipment have been included in an Application for Payment recommended by Engineer;
 5. allow for partial utilization of the Work by Owner;
 6. include testing and startup; and
 7. be maintained in effect until final payment is made unless otherwise agreed to in writing by Owner, Contractor, and Engineer with 30 days written notice to each other loss payee to whom a certificate of insurance has been issued.
- B. Owner shall purchase and maintain such equipment breakdown insurance or additional property insurance as may be required by the Supplementary Conditions or Laws and Regulations which will include the interests of Owner, Contractor, Subcontractors, and Engineer, and any other individuals or entities identified in the Supplementary Conditions, and the officers, directors,

members, partners, employees, agents, consultants and subcontractors of each and any of them, each of whom is deemed to have an insurable interest and shall be listed as a loss payee.

- C. All the policies of insurance (and the certificates or other evidence thereof) required to be purchased and maintained in accordance with this Paragraph 5.06 will contain a provision or endorsement that the coverage afforded will not be canceled or materially changed or renewal refused until at least 30 days prior written notice has been given to Owner and Contractor and to each other loss payee to whom a certificate of insurance has been issued and will contain waiver provisions in accordance with Paragraph 5.07.
- D. Owner shall not be responsible for purchasing and maintaining any property insurance specified in this Paragraph 5.06 to protect the interests of Contractor, Subcontractors, or others in the Work to the extent of any deductible amounts that are identified in the Supplementary Conditions. The risk of loss within such identified deductible amount will be borne by Contractor, Subcontractors, or others suffering any such loss, and if any of them wishes property insurance coverage within the limits of such amounts, each may purchase and maintain it at the purchaser's own expense.
- E. If Contractor requests in writing that other special insurance be included in the property insurance policies provided under this Paragraph 5.06, Owner shall, if possible, include such insurance, and the cost thereof will be charged to Contractor by appropriate Change Order. Prior to commencement of the Work at the Site, Owner shall in writing advise Contractor whether or not such other insurance has been procured by Owner.

5.07 *Waiver of Rights*

- A. Owner and Contractor intend that all policies purchased in accordance with Paragraph 5.06 will protect Owner, Contractor, Subcontractors, and Engineer, and all other individuals or entities identified in the Supplementary Conditions as loss payees (and the officers, directors, members, partners, employees, agents, consultants, and subcontractors of each and any of them) in such policies and will provide primary coverage for all losses and damages caused by the perils or causes of loss covered thereby. All such policies shall contain provisions to the effect that in the event of payment of any loss or damage the insurers will have no rights of recovery against any of the insureds or loss payees thereunder. Owner and Contractor waive all rights against each other and their respective officers, directors, members, partners, employees, agents, consultants and subcontractors of each and any of them for all losses and damages caused by, arising out of or resulting from any of the perils or causes of loss covered by such policies and any other property insurance applicable to the Work; and, in addition, waive all such rights against Subcontractors and Engineer, and all other individuals or entities identified in the Supplementary Conditions as loss payees (and the officers, directors, members, partners, employees, agents, consultants, and subcontractors of each and any of them) under such policies for losses and damages so caused. None of the above waivers shall extend to the rights that any party making such waiver may have to the proceeds of insurance held by Owner as trustee or otherwise payable under any policy so issued.
- B. Owner waives all rights against Contractor, Subcontractors, and Engineer, and the officers, directors, members, partners, employees, agents, consultants and subcontractors of each and any of them for:

1. loss due to business interruption, loss of use, or other consequential loss extending beyond direct physical loss or damage to Owner's property or the Work caused by, arising out of, or resulting from fire or other perils whether or not insured by Owner; and
 2. loss or damage to the completed Project or part thereof caused by, arising out of, or resulting from fire or other insured peril or cause of loss covered by any property insurance maintained on the completed Project or part thereof by Owner during partial utilization pursuant to Paragraph 14.05, after Substantial Completion pursuant to Paragraph 14.04, or after final payment pursuant to Paragraph 14.07.
- C. Any insurance policy maintained by Owner covering any loss, damage or consequential loss referred to in Paragraph 5.07.B shall contain provisions to the effect that in the event of payment of any such loss, damage, or consequential loss, the insurers will have no rights of recovery against Contractor, Subcontractors, or Engineer, and the officers, directors, members, partners, employees, agents, consultants and subcontractors of each and any of them.

5.08 *Receipt and Application of Insurance Proceeds*

- A. Any insured loss under the policies of insurance required by Paragraph 5.06 will be adjusted with Owner and made payable to Owner as fiduciary for the loss payees, as their interests may appear, subject to the requirements of any applicable mortgage clause and of Paragraph 5.08.B. Owner shall deposit in a separate account any money so received and shall distribute it in accordance with such agreement as the parties in interest may reach. If no other special agreement is reached, the damaged Work shall be repaired or replaced, the moneys so received applied on account thereof, and the Work and the cost thereof covered by an appropriate Change Order.
- B. Owner as fiduciary shall have power to adjust and settle any loss with the insurers unless one of the parties in interest shall object in writing within 15 days after the occurrence of loss to Owner's exercise of this power. If such objection be made, Owner as fiduciary shall make settlement with the insurers in accordance with such agreement as the parties in interest may reach. If no such agreement among the parties in interest is reached, Owner as fiduciary shall adjust and settle the loss with the insurers and, if required in writing by any party in interest, Owner as fiduciary shall give bond for the proper performance of such duties.

5.09 *Acceptance of Bonds and Insurance; Option to Replace*

- A. If either Owner or Contractor has any objection to the coverage afforded by or other provisions of the bonds or insurance required to be purchased and maintained by the other party in accordance with Article 5 on the basis of non-conformance with the Contract Documents, the objecting party shall so notify the other party in writing within 10 days after receipt of the certificates (or other evidence requested) required by Paragraph 2.01.B. Owner and Contractor shall each provide to the other such additional information in respect of insurance provided as the other may reasonably request. If either party does not purchase or maintain all of the bonds and insurance required of such party by the Contract Documents, such party shall notify the other party in writing of such failure to purchase prior to the start of the Work, or of such failure to maintain prior to any change in the required coverage. Without prejudice to any other right or remedy, the other party may elect to obtain equivalent bonds or insurance to protect such other party's

interests at the expense of the party who was required to provide such coverage, and a Change Order shall be issued to adjust the Contract Price accordingly.

5.10 *Partial Utilization, Acknowledgment of Property Insurer*

- A. If Owner finds it necessary to occupy or use a portion or portions of the Work prior to Substantial Completion of all the Work as provided in Paragraph 14.05, no such use or occupancy shall commence before the insurers providing the property insurance pursuant to Paragraph 5.06 have acknowledged notice thereof and in writing effected any changes in coverage necessitated thereby. The insurers providing the property insurance shall consent by endorsement on the policy or policies, but the property insurance shall not be canceled or permitted to lapse on account of any such partial use or occupancy.

ARTICLE 6 – CONTRACTOR’S RESPONSIBILITIES

6.01 *Supervision and Superintendence*

- A. Contractor shall supervise, inspect, and direct the Work competently and efficiently, devoting such attention thereto and applying such skills and expertise as may be necessary to perform the Work in accordance with the Contract Documents. Contractor shall be solely responsible for the means, methods, techniques, sequences, and procedures of construction. Contractor shall not be responsible for the negligence of Owner or Engineer in the design or specification of a specific means, method, technique, sequence, or procedure of construction which is shown or indicated in and expressly required by the Contract Documents.
- B. At all times during the progress of the Work, Contractor shall assign a competent resident superintendent who shall not be replaced without written notice to Owner and Engineer except under extraordinary circumstances.

6.02 *Labor; Working Hours*

- A. Contractor shall provide competent, suitably qualified personnel to survey and lay out the Work and perform construction as required by the Contract Documents. Contractor shall at all times maintain good discipline and order at the Site.
- B. Except as otherwise required for the safety or protection of persons or the Work or property at the Site or adjacent thereto, and except as otherwise stated in the Contract Documents, all Work at the Site shall be performed during regular working hours. Contractor will not permit the performance of Work on a Saturday, Sunday, or any legal holiday without Owner’s written consent (which will not be unreasonably withheld) given after prior written notice to Engineer.

6.03 *Services, Materials, and Equipment*

- A. Unless otherwise specified in the Contract Documents, Contractor shall provide and assume full responsibility for all services, materials, equipment, labor, transportation, construction equipment and machinery, tools, appliances, fuel, power, light, heat, telephone, water, sanitary facilities, temporary facilities, and all other facilities and incidentals necessary for the performance, testing, start-up, and completion of the Work.

- B. All materials and equipment incorporated into the Work shall be as specified or, if not specified, shall be of good quality and new, except as otherwise provided in the Contract Documents. All special warranties and guarantees required by the Specifications shall expressly run to the benefit of Owner. If required by Engineer, Contractor shall furnish satisfactory evidence (including reports of required tests) as to the source, kind, and quality of materials and equipment.
- C. All materials and equipment shall be stored, applied, installed, connected, erected, protected, used, cleaned, and conditioned in accordance with instructions of the applicable Supplier, except as otherwise may be provided in the Contract Documents.

6.04 *Progress Schedule*

- A. Contractor shall adhere to the Progress Schedule established in accordance with Paragraph 2.07 as it may be adjusted from time to time as provided below.
 - 1. Contractor shall submit to Engineer for acceptance (to the extent indicated in Paragraph 2.07) proposed adjustments in the Progress Schedule that will not result in changing the Contract Times. Such adjustments will comply with any provisions of the General Requirements applicable thereto.
 - 2. Proposed adjustments in the Progress Schedule that will change the Contract Times shall be submitted in accordance with the requirements of Article 12. Adjustments in Contract Times may only be made by a Change Order.

6.05 *Substitutes and "Or-Equals"*

- A. Whenever an item of material or equipment is specified or described in the Contract Documents by using the name of a proprietary item or the name of a particular Supplier, the specification or description is intended to establish the type, function, appearance, and quality required. Unless the specification or description contains or is followed by words reading that no like, equivalent, or "or-equal" item or no substitution is permitted, other items of material or equipment or material or equipment of other Suppliers may be submitted to Engineer for review under the circumstances described below.
 - 1. "*Or-Equal*" Items: If in Engineer's sole discretion an item of material or equipment proposed by Contractor is functionally equal to that named and sufficiently similar so that no change in related Work will be required, it may be considered by Engineer as an "or-equal" item, in which case review and approval of the proposed item may, in Engineer's sole discretion, be accomplished without compliance with some or all of the requirements for approval of proposed substitute items. For the purposes of this Paragraph 6.05.A.1, a proposed item of material or equipment will be considered functionally equal to an item so named if:
 - a. in the exercise of reasonable judgment Engineer determines that:
 - 1) it is at least equal in materials of construction, quality, durability, appearance, strength, and design characteristics;

- 2) it will reliably perform at least equally well the function and achieve the results imposed by the design concept of the completed Project as a functioning whole; and
 - 3) it has a proven record of performance and availability of responsive service.
- b. Contractor certifies that, if approved and incorporated into the Work:
- 1) there will be no increase in cost to the Owner or increase in Contract Times; and
 - 2) it will conform substantially to the detailed requirements of the item named in the Contract Documents.

2. *Substitute Items:*

- a. If in Engineer's sole discretion an item of material or equipment proposed by Contractor does not qualify as an "or-equal" item under Paragraph 6.05.A.1, it will be considered a proposed substitute item.
- b. Contractor shall submit sufficient information as provided below to allow Engineer to determine if the item of material or equipment proposed is essentially equivalent to that named and an acceptable substitute therefor. Requests for review of proposed substitute items of material or equipment will not be accepted by Engineer from anyone other than Contractor.
- c. The requirements for review by Engineer will be as set forth in Paragraph 6.05.A.2.d, as supplemented by the General Requirements, and as Engineer may decide is appropriate under the circumstances.
- d. Contractor shall make written application to Engineer for review of a proposed substitute item of material or equipment that Contractor seeks to furnish or use. The application:
 - 1) shall certify that the proposed substitute item will:
 - a) perform adequately the functions and achieve the results called for by the general design,
 - b) be similar in substance to that specified, and
 - c) be suited to the same use as that specified;
 - 2) will state:
 - a) the extent, if any, to which the use of the proposed substitute item will prejudice Contractor's achievement of Substantial Completion on time,
 - b) whether use of the proposed substitute item in the Work will require a change in any of the Contract Documents (or in the provisions of any other direct contract with Owner for other work on the Project) to adapt the design to the proposed substitute item, and

- c) whether incorporation or use of the proposed substitute item in connection with the Work is subject to payment of any license fee or royalty;
 - 3) will identify:
 - a) all variations of the proposed substitute item from that specified, and
 - b) available engineering, sales, maintenance, repair, and replacement services; and
 - 4) shall contain an itemized estimate of all costs or credits that will result directly or indirectly from use of such substitute item, including costs of redesign and claims of other contractors affected by any resulting change.
- B. *Substitute Construction Methods or Procedures:* If a specific means, method, technique, sequence, or procedure of construction is expressly required by the Contract Documents, Contractor may furnish or utilize a substitute means, method, technique, sequence, or procedure of construction approved by Engineer. Contractor shall submit sufficient information to allow Engineer, in Engineer's sole discretion, to determine that the substitute proposed is equivalent to that expressly called for by the Contract Documents. The requirements for review by Engineer will be similar to those provided in Paragraph 6.05.A.2.
- C. *Engineer's Evaluation:* Engineer will be allowed a reasonable time within which to evaluate each proposal or submittal made pursuant to Paragraphs 6.05.A and 6.05.B. Engineer may require Contractor to furnish additional data about the proposed substitute item. Engineer will be the sole judge of acceptability. No "or equal" or substitute will be ordered, installed or utilized until Engineer's review is complete, which will be evidenced by a Change Order in the case of a substitute and an approved Shop Drawing for an "or equal." Engineer will advise Contractor in writing of any negative determination.
- D. *Special Guarantee:* Owner may require Contractor to furnish at Contractor's expense a special performance guarantee or other surety with respect to any substitute.
- E. *Engineer's Cost Reimbursement:* Engineer will record Engineer's costs in evaluating a substitute proposed or submitted by Contractor pursuant to Paragraphs 6.05.A.2 and 6.05.B. Whether or not Engineer approves a substitute so proposed or submitted by Contractor, Contractor shall reimburse Owner for the reasonable charges of Engineer for evaluating each such proposed substitute. Contractor shall also reimburse Owner for the reasonable charges of Engineer for making changes in the Contract Documents (or in the provisions of any other direct contract with Owner) resulting from the acceptance of each proposed substitute.
- F. *Contractor's Expense:* Contractor shall provide all data in support of any proposed substitute or "or-equal" at Contractor's expense.

6.06 *Concerning Subcontractors, Suppliers, and Others*

- A. Contractor shall not employ any Subcontractor, Supplier, or other individual or entity (including those acceptable to Owner as indicated in Paragraph 6.06.B), whether initially or as a replacement, against whom Owner may have reasonable objection. Contractor shall not be

required to employ any Subcontractor, Supplier, or other individual or entity to furnish or perform any of the Work against whom Contractor has reasonable objection.

- B. If the Supplementary Conditions require the identity of certain Subcontractors, Suppliers, or other individuals or entities to be submitted to Owner in advance for acceptance by Owner by a specified date prior to the Effective Date of the Agreement, and if Contractor has submitted a list thereof in accordance with the Supplementary Conditions, Owner's acceptance (either in writing or by failing to make written objection thereto by the date indicated for acceptance or objection in the Bidding Documents or the Contract Documents) of any such Subcontractor, Supplier, or other individual or entity so identified may be revoked on the basis of reasonable objection after due investigation. Contractor shall submit an acceptable replacement for the rejected Subcontractor, Supplier, or other individual or entity, and the Contract Price will be adjusted by the difference in the cost occasioned by such replacement, and an appropriate Change Order will be issued. No acceptance by Owner of any such Subcontractor, Supplier, or other individual or entity, whether initially or as a replacement, shall constitute a waiver of any right of Owner or Engineer to reject defective Work.
- C. Contractor shall be fully responsible to Owner and Engineer for all acts and omissions of the Subcontractors, Suppliers, and other individuals or entities performing or furnishing any of the Work just as Contractor is responsible for Contractor's own acts and omissions. Nothing in the Contract Documents:
1. shall create for the benefit of any such Subcontractor, Supplier, or other individual or entity any contractual relationship between Owner or Engineer and any such Subcontractor, Supplier or other individual or entity; nor
 2. shall create any obligation on the part of Owner or Engineer to pay or to see to the payment of any moneys due any such Subcontractor, Supplier, or other individual or entity except as may otherwise be required by Laws and Regulations.
- D. Contractor shall be solely responsible for scheduling and coordinating the Work of Subcontractors, Suppliers, and other individuals or entities performing or furnishing any of the Work under a direct or indirect contract with Contractor.
- E. Contractor shall require all Subcontractors, Suppliers, and such other individuals or entities performing or furnishing any of the Work to communicate with Engineer through Contractor.
- F. The divisions and sections of the Specifications and the identifications of any Drawings shall not control Contractor in dividing the Work among Subcontractors or Suppliers or delineating the Work to be performed by any specific trade.
- G. All Work performed for Contractor by a Subcontractor or Supplier will be pursuant to an appropriate agreement between Contractor and the Subcontractor or Supplier which specifically binds the Subcontractor or Supplier to the applicable terms and conditions of the Contract Documents for the benefit of Owner and Engineer. Whenever any such agreement is with a Subcontractor or Supplier who is listed as a loss payee on the property insurance provided in Paragraph 5.06, the agreement between the Contractor and the Subcontractor or Supplier will contain provisions whereby the Subcontractor or Supplier waives all rights against Owner,

Contractor, Engineer, and all other individuals or entities identified in the Supplementary Conditions to be listed as insureds or loss payees (and the officers, directors, members, partners, employees, agents, consultants, and subcontractors of each and any of them) for all losses and damages caused by, arising out of, relating to, or resulting from any of the perils or causes of loss covered by such policies and any other property insurance applicable to the Work. If the insurers on any such policies require separate waiver forms to be signed by any Subcontractor or Supplier, Contractor will obtain the same.

6.07 *Patent Fees and Royalties*

- A. Contractor shall pay all license fees and royalties and assume all costs incident to the use in the performance of the Work or the incorporation in the Work of any invention, design, process, product, or device which is the subject of patent rights or copyrights held by others. If a particular invention, design, process, product, or device is specified in the Contract Documents for use in the performance of the Work and if, to the actual knowledge of Owner or Engineer, its use is subject to patent rights or copyrights calling for the payment of any license fee or royalty to others, the existence of such rights shall be disclosed by Owner in the Contract Documents.
- B. To the fullest extent permitted by Laws and Regulations, Owner shall indemnify and hold harmless Contractor, and its officers, directors, members, partners, employees, agents, consultants, and subcontractors from and against all claims, costs, losses, and damages (including but not limited to all fees and charges of engineers, architects, attorneys, and other professionals, and all court or arbitration or other dispute resolution costs) arising out of or relating to any infringement of patent rights or copyrights incident to the use in the performance of the Work or resulting from the incorporation in the Work of any invention, design, process, product, or device specified in the Contract Documents, but not identified as being subject to payment of any license fee or royalty to others required by patent rights or copyrights.
- C. To the fullest extent permitted by Laws and Regulations, Contractor shall indemnify and hold harmless Owner and Engineer, and the officers, directors, members, partners, employees, agents, consultants and subcontractors of each and any of them from and against all claims, costs, losses, and damages (including but not limited to all fees and charges of engineers, architects, attorneys, and other professionals and all court or arbitration or other dispute resolution costs) arising out of or relating to any infringement of patent rights or copyrights incident to the use in the performance of the Work or resulting from the incorporation in the Work of any invention, design, process, product, or device not specified in the Contract Documents.

6.08 *Permits*

- A. Unless otherwise provided in the Supplementary Conditions, Contractor shall obtain and pay for all construction permits and licenses. Owner shall assist Contractor, when necessary, in obtaining such permits and licenses. Contractor shall pay all governmental charges and inspection fees necessary for the prosecution of the Work which are applicable at the time of opening of Bids, or, if there are no Bids, on the Effective Date of the Agreement. Owner shall pay all charges of utility owners for connections for providing permanent service to the Work.

6.09 *Laws and Regulations*

- A. Contractor shall give all notices required by and shall comply with all Laws and Regulations applicable to the performance of the Work. Except where otherwise expressly required by applicable Laws and Regulations, neither Owner nor Engineer shall be responsible for monitoring Contractor's compliance with any Laws or Regulations.
- B. If Contractor performs any Work knowing or having reason to know that it is contrary to Laws or Regulations, Contractor shall bear all claims, costs, losses, and damages (including but not limited to all fees and charges of engineers, architects, attorneys, and other professionals and all court or arbitration or other dispute resolution costs) arising out of or relating to such Work. However, it shall not be Contractor's responsibility to make certain that the Specifications and Drawings are in accordance with Laws and Regulations, but this shall not relieve Contractor of Contractor's obligations under Paragraph 3.03.
- C. Changes in Laws or Regulations not known at the time of opening of Bids (or, on the Effective Date of the Agreement if there were no Bids) having an effect on the cost or time of performance of the Work shall be the subject of an adjustment in Contract Price or Contract Times. If Owner and Contractor are unable to agree on entitlement to or on the amount or extent, if any, of any such adjustment, a Claim may be made therefor as provided in Paragraph 10.05.

6.10 *Taxes*

- A. Contractor shall pay all sales, consumer, use, and other similar taxes required to be paid by Contractor in accordance with the Laws and Regulations of the place of the Project which are applicable during the performance of the Work.

6.11 *Use of Site and Other Areas*

A. *Limitation on Use of Site and Other Areas:*

1. Contractor shall confine construction equipment, the storage of materials and equipment, and the operations of workers to the Site and other areas permitted by Laws and Regulations, and shall not unreasonably encumber the Site and other areas with construction equipment or other materials or equipment. Contractor shall assume full responsibility for any damage to any such land or area, or to the owner or occupant thereof, or of any adjacent land or areas resulting from the performance of the Work.
2. Should any claim be made by any such owner or occupant because of the performance of the Work, Contractor shall promptly settle with such other party by negotiation or otherwise resolve the claim by arbitration or other dispute resolution proceeding or at law.
3. To the fullest extent permitted by Laws and Regulations, Contractor shall indemnify and hold harmless Owner and Engineer, and the officers, directors, members, partners, employees, agents, consultants and subcontractors of each and any of them from and against all claims, costs, losses, and damages (including but not limited to all fees and charges of engineers, architects, attorneys, and other professionals and all court or arbitration or other dispute resolution costs) arising out of or relating to any claim or action, legal or equitable, brought

by any such owner or occupant against Owner, Engineer, or any other party indemnified hereunder to the extent caused by or based upon Contractor's performance of the Work.

- B. *Removal of Debris During Performance of the Work:* During the progress of the Work Contractor shall keep the Site and other areas free from accumulations of waste materials, rubbish, and other debris. Removal and disposal of such waste materials, rubbish, and other debris shall conform to applicable Laws and Regulations.
- C. *Cleaning:* Prior to Substantial Completion of the Work Contractor shall clean the Site and the Work and make it ready for utilization by Owner. At the completion of the Work Contractor shall remove from the Site all tools, appliances, construction equipment and machinery, and surplus materials and shall restore to original condition all property not designated for alteration by the Contract Documents.
- D. *Loading Structures:* Contractor shall not load nor permit any part of any structure to be loaded in any manner that will endanger the structure, nor shall Contractor subject any part of the Work or adjacent property to stresses or pressures that will endanger it.

6.12 *Record Documents*

- A. Contractor shall maintain in a safe place at the Site one record copy of all Drawings, Specifications, Addenda, Change Orders, Work Change Directives, Field Orders, and written interpretations and clarifications in good order and annotated to show changes made during construction. These record documents together with all approved Samples and a counterpart of all approved Shop Drawings will be available to Engineer for reference. Upon completion of the Work, these record documents, Samples, and Shop Drawings will be delivered to Engineer for Owner.

6.13 *Safety and Protection*

- A. Contractor shall be solely responsible for initiating, maintaining and supervising all safety precautions and programs in connection with the Work. Such responsibility does not relieve Subcontractors of their responsibility for the safety of persons or property in the performance of their work, nor for compliance with applicable safety Laws and Regulations. Contractor shall take all necessary precautions for the safety of, and shall provide the necessary protection to prevent damage, injury or loss to:
 - 1. all persons on the Site or who may be affected by the Work;
 - 2. all the Work and materials and equipment to be incorporated therein, whether in storage on or off the Site; and
 - 3. other property at the Site or adjacent thereto, including trees, shrubs, lawns, walks, pavements, roadways, structures, utilities, and Underground Facilities not designated for removal, relocation, or replacement in the course of construction.
- B. Contractor shall comply with all applicable Laws and Regulations relating to the safety of persons or property, or to the protection of persons or property from damage, injury, or loss; and

shall erect and maintain all necessary safeguards for such safety and protection. Contractor shall notify owners of adjacent property and of Underground Facilities and other utility owners when prosecution of the Work may affect them, and shall cooperate with them in the protection, removal, relocation, and replacement of their property.

- C. Contractor shall comply with the applicable requirements of Owner's safety programs, if any. The Supplementary Conditions identify any Owner's safety programs that are applicable to the Work.
- D. Contractor shall inform Owner and Engineer of the specific requirements of Contractor's safety program with which Owner's and Engineer's employees and representatives must comply while at the Site.
- E. All damage, injury, or loss to any property referred to in Paragraph 6.13.A.2 or 6.13.A.3 caused, directly or indirectly, in whole or in part, by Contractor, any Subcontractor, Supplier, or any other individual or entity directly or indirectly employed by any of them to perform any of the Work, or anyone for whose acts any of them may be liable, shall be remedied by Contractor (except damage or loss attributable to the fault of Drawings or Specifications or to the acts or omissions of Owner or Engineer or anyone employed by any of them, or anyone for whose acts any of them may be liable, and not attributable, directly or indirectly, in whole or in part, to the fault or negligence of Contractor or any Subcontractor, Supplier, or other individual or entity directly or indirectly employed by any of them).
- F. Contractor's duties and responsibilities for safety and for protection of the Work shall continue until such time as all the Work is completed and Engineer has issued a notice to Owner and Contractor in accordance with Paragraph 14.07.B that the Work is acceptable (except as otherwise expressly provided in connection with Substantial Completion).

6.14 *Safety Representative*

- A. Contractor shall designate a qualified and experienced safety representative at the Site whose duties and responsibilities shall be the prevention of accidents and the maintaining and supervising of safety precautions and programs.

6.15 *Hazard Communication Programs*

- A. Contractor shall be responsible for coordinating any exchange of material safety data sheets or other hazard communication information required to be made available to or exchanged between or among employers at the Site in accordance with Laws or Regulations.

6.16 *Emergencies*

- A. In emergencies affecting the safety or protection of persons or the Work or property at the Site or adjacent thereto, Contractor is obligated to act to prevent threatened damage, injury, or loss. Contractor shall give Engineer prompt written notice if Contractor believes that any significant changes in the Work or variations from the Contract Documents have been caused thereby or are required as a result thereof. If Engineer determines that a change in the Contract Documents is

required because of the action taken by Contractor in response to such an emergency, a Work Change Directive or Change Order will be issued.

6.17 *Shop Drawings and Samples*

A. Contractor shall submit Shop Drawings and Samples to Engineer for review and approval in accordance with the accepted Schedule of Submittals (as required by Paragraph 2.07). Each submittal will be identified as Engineer may require.

1. *Shop Drawings:*

- a. Submit number of copies specified in the General Requirements.
- b. Data shown on the Shop Drawings will be complete with respect to quantities, dimensions, specified performance and design criteria, materials, and similar data to show Engineer the services, materials, and equipment Contractor proposes to provide and to enable Engineer to review the information for the limited purposes required by Paragraph 6.17.D.

2. *Samples:*

- a. Submit number of Samples specified in the Specifications.
- b. Clearly identify each Sample as to material, Supplier, pertinent data such as catalog numbers, the use for which intended and other data as Engineer may require to enable Engineer to review the submittal for the limited purposes required by Paragraph 6.17.D.

B. Where a Shop Drawing or Sample is required by the Contract Documents or the Schedule of Submittals, any related Work performed prior to Engineer's review and approval of the pertinent submittal will be at the sole expense and responsibility of Contractor.

C. *Submittal Procedures:*

1. Before submitting each Shop Drawing or Sample, Contractor shall have:

- a. reviewed and coordinated each Shop Drawing or Sample with other Shop Drawings and Samples and with the requirements of the Work and the Contract Documents;
- b. determined and verified all field measurements, quantities, dimensions, specified performance and design criteria, installation requirements, materials, catalog numbers, and similar information with respect thereto;
- c. determined and verified the suitability of all materials offered with respect to the indicated application, fabrication, shipping, handling, storage, assembly, and installation pertaining to the performance of the Work; and
- d. determined and verified all information relative to Contractor's responsibilities for means, methods, techniques, sequences, and procedures of construction, and safety precautions and programs incident thereto.

2. Each submittal shall bear a stamp or specific written certification that Contractor has satisfied Contractor's obligations under the Contract Documents with respect to Contractor's review and approval of that submittal.
3. With each submittal, Contractor shall give Engineer specific written notice of any variations that the Shop Drawing or Sample may have from the requirements of the Contract Documents. This notice shall be both a written communication separate from the Shop Drawings or Sample submittal; and, in addition, by a specific notation made on each Shop Drawing or Sample submitted to Engineer for review and approval of each such variation.

D. *Engineer's Review:*

1. Engineer will provide timely review of Shop Drawings and Samples in accordance with the Schedule of Submittals acceptable to Engineer. Engineer's review and approval will be only to determine if the items covered by the submittals will, after installation or incorporation in the Work, conform to the information given in the Contract Documents and be compatible with the design concept of the completed Project as a functioning whole as indicated by the Contract Documents.
2. Engineer's review and approval will not extend to means, methods, techniques, sequences, or procedures of construction (except where a particular means, method, technique, sequence, or procedure of construction is specifically and expressly called for by the Contract Documents) or to safety precautions or programs incident thereto. The review and approval of a separate item as such will not indicate approval of the assembly in which the item functions.
3. Engineer's review and approval shall not relieve Contractor from responsibility for any variation from the requirements of the Contract Documents unless Contractor has complied with the requirements of Paragraph 6.17.C.3 and Engineer has given written approval of each such variation by specific written notation thereof incorporated in or accompanying the Shop Drawing or Sample. Engineer's review and approval shall not relieve Contractor from responsibility for complying with the requirements of Paragraph 6.17.C.1.

E. *Resubmittal Procedures:*

1. Contractor shall make corrections required by Engineer and shall return the required number of corrected copies of Shop Drawings and submit, as required, new Samples for review and approval. Contractor shall direct specific attention in writing to revisions other than the corrections called for by Engineer on previous submittals.

6.18 *Continuing the Work*

- A. Contractor shall carry on the Work and adhere to the Progress Schedule during all disputes or disagreements with Owner. No Work shall be delayed or postponed pending resolution of any disputes or disagreements, except as permitted by Paragraph 15.04 or as Owner and Contractor may otherwise agree in writing.

6.19 *Contractor's General Warranty and Guarantee*

- A. Contractor warrants and guarantees to Owner that all Work will be in accordance with the Contract Documents and will not be defective. Engineer and its officers, directors, members, partners, employees, agents, consultants, and subcontractors shall be entitled to rely on representation of Contractor's warranty and guarantee.
- B. Contractor's warranty and guarantee hereunder excludes defects or damage caused by:
1. abuse, modification, or improper maintenance or operation by persons other than Contractor, Subcontractors, Suppliers, or any other individual or entity for whom Contractor is responsible; or
 2. normal wear and tear under normal usage.
- C. Contractor's obligation to perform and complete the Work in accordance with the Contract Documents shall be absolute. None of the following will constitute an acceptance of Work that is not in accordance with the Contract Documents or a release of Contractor's obligation to perform the Work in accordance with the Contract Documents:
1. observations by Engineer;
 2. recommendation by Engineer or payment by Owner of any progress or final payment;
 3. the issuance of a certificate of Substantial Completion by Engineer or any payment related thereto by Owner;
 4. use or occupancy of the Work or any part thereof by Owner;
 5. any review and approval of a Shop Drawing or Sample submittal or the issuance of a notice of acceptability by Engineer;
 6. any inspection, test, or approval by others; or
 7. any correction of defective Work by Owner.

6.20 *Indemnification*

- A. To the fullest extent permitted by Laws and Regulations, Contractor shall indemnify and hold harmless Owner and Engineer, and the officers, directors, members, partners, employees, agents, consultants and subcontractors of each and any of them from and against all claims, costs, losses, and damages (including but not limited to all fees and charges of engineers, architects, attorneys, and other professionals and all court or arbitration or other dispute resolution costs) arising out of or relating to the performance of the Work, provided that any such claim, cost, loss, or damage is attributable to bodily injury, sickness, disease, or death, or to injury to or destruction of tangible property (other than the Work itself), including the loss of use resulting therefrom but only to the extent caused by any negligent act or omission of Contractor, any Subcontractor, any Supplier, or any individual or entity directly or indirectly employed by any of them to perform any of the Work or anyone for whose acts any of them may be liable .

- B. In any and all claims against Owner or Engineer or any of their officers, directors, members, partners, employees, agents, consultants, or subcontractors by any employee (or the survivor or personal representative of such employee) of Contractor, any Subcontractor, any Supplier, or any individual or entity directly or indirectly employed by any of them to perform any of the Work, or anyone for whose acts any of them may be liable, the indemnification obligation under Paragraph 6.20.A shall not be limited in any way by any limitation on the amount or type of damages, compensation, or benefits payable by or for Contractor or any such Subcontractor, Supplier, or other individual or entity under workers' compensation acts, disability benefit acts, or other employee benefit acts.
- C. The indemnification obligations of Contractor under Paragraph 6.20.A shall not extend to the liability of Engineer and Engineer's officers, directors, members, partners, employees, agents, consultants and subcontractors arising out of:
 - 1. the preparation or approval of, or the failure to prepare or approve maps, Drawings, opinions, reports, surveys, Change Orders, designs, or Specifications; or
 - 2. giving directions or instructions, or failing to give them, if that is the primary cause of the injury or damage.

6.21 *Delegation of Professional Design Services*

- A. Contractor will not be required to provide professional design services unless such services are specifically required by the Contract Documents for a portion of the Work or unless such services are required to carry out Contractor's responsibilities for construction means, methods, techniques, sequences and procedures. Contractor shall not be required to provide professional services in violation of applicable law.
- B. If professional design services or certifications by a design professional related to systems, materials or equipment are specifically required of Contractor by the Contract Documents, Owner and Engineer will specify all performance and design criteria that such services must satisfy. Contractor shall cause such services or certifications to be provided by a properly licensed professional, whose signature and seal shall appear on all drawings, calculations, specifications, certifications, Shop Drawings and other submittals prepared by such professional. Shop Drawings and other submittals related to the Work designed or certified by such professional, if prepared by others, shall bear such professional's written approval when submitted to Engineer.
- C. Owner and Engineer shall be entitled to rely upon the adequacy, accuracy and completeness of the services, certifications or approvals performed by such design professionals, provided Owner and Engineer have specified to Contractor all performance and design criteria that such services must satisfy.
- D. Pursuant to this Paragraph 6.21, Engineer's review and approval of design calculations and design drawings will be only for the limited purpose of checking for conformance with performance and design criteria given and the design concept expressed in the Contract Documents. Engineer's review and approval of Shop Drawings and other submittals (except design calculations and design drawings) will be only for the purpose stated in Paragraph 6.17.D.1.

- E. Contractor shall not be responsible for the adequacy of the performance or design criteria required by the Contract Documents.

ARTICLE 7 – OTHER WORK AT THE SITE

7.01 Related Work at Site

- A. Owner may perform other work related to the Project at the Site with Owner’s employees, or through other direct contracts therefor, or have other work performed by utility owners. If such other work is not noted in the Contract Documents, then:
 - 1. written notice thereof will be given to Contractor prior to starting any such other work; and
 - 2. if Owner and Contractor are unable to agree on entitlement to or on the amount or extent, if any, of any adjustment in the Contract Price or Contract Times that should be allowed as a result of such other work, a Claim may be made therefor as provided in Paragraph 10.05.
- B. Contractor shall afford each other contractor who is a party to such a direct contract, each utility owner, and Owner, if Owner is performing other work with Owner’s employees, proper and safe access to the Site, provide a reasonable opportunity for the introduction and storage of materials and equipment and the execution of such other work, and properly coordinate the Work with theirs. Contractor shall do all cutting, fitting, and patching of the Work that may be required to properly connect or otherwise make its several parts come together and properly integrate with such other work. Contractor shall not endanger any work of others by cutting, excavating, or otherwise altering such work; provided, however, that Contractor may cut or alter others' work with the written consent of Engineer and the others whose work will be affected. The duties and responsibilities of Contractor under this Paragraph are for the benefit of such utility owners and other contractors to the extent that there are comparable provisions for the benefit of Contractor in said direct contracts between Owner and such utility owners and other contractors.
- C. If the proper execution or results of any part of Contractor’s Work depends upon work performed by others under this Article 7, Contractor shall inspect such other work and promptly report to Engineer in writing any delays, defects, or deficiencies in such other work that render it unavailable or unsuitable for the proper execution and results of Contractor’s Work. Contractor’s failure to so report will constitute an acceptance of such other work as fit and proper for integration with Contractor’s Work except for latent defects and deficiencies in such other work.

7.02 Coordination

- A. If Owner intends to contract with others for the performance of other work on the Project at the Site, the following will be set forth in Supplementary Conditions:
 - 1. the individual or entity who will have authority and responsibility for coordination of the activities among the various contractors will be identified;
 - 2. the specific matters to be covered by such authority and responsibility will be itemized; and
 - 3. the extent of such authority and responsibilities will be provided.

- B. Unless otherwise provided in the Supplementary Conditions, Owner shall have sole authority and responsibility for such coordination.

7.03 *Legal Relationships*

- A. Paragraphs 7.01.A and 7.02 are not applicable for utilities not under the control of Owner.
- B. Each other direct contract of Owner under Paragraph 7.01.A shall provide that the other contractor is liable to Owner and Contractor for the reasonable direct delay and disruption costs incurred by Contractor as a result of the other contractor's wrongful actions or inactions.
- C. Contractor shall be liable to Owner and any other contractor under direct contract to Owner for the reasonable direct delay and disruption costs incurred by such other contractor as a result of Contractor's wrongful action or inactions.

ARTICLE 8 – OWNER'S RESPONSIBILITIES

8.01 *Communications to Contractor*

- A. Except as otherwise provided in these General Conditions, Owner shall issue all communications to Contractor through Engineer.

8.02 *Replacement of Engineer*

- A. In case of termination of the employment of Engineer, Owner shall appoint an engineer to whom Contractor makes no reasonable objection, whose status under the Contract Documents shall be that of the former Engineer.

8.03 *Furnish Data*

- A. Owner shall promptly furnish the data required of Owner under the Contract Documents.

8.04 *Pay When Due*

- A. Owner shall make payments to Contractor when they are due as provided in Paragraphs 14.02.C and 14.07.C.

8.05 *Lands and Easements; Reports and Tests*

- A. Owner's duties with respect to providing lands and easements and providing engineering surveys to establish reference points are set forth in Paragraphs 4.01 and 4.05. Paragraph 4.02 refers to Owner's identifying and making available to Contractor copies of reports of explorations and tests of subsurface conditions and drawings of physical conditions relating to existing surface or subsurface structures at the Site.

8.06 *Insurance*

- A. Owner's responsibilities, if any, with respect to purchasing and maintaining liability and property insurance are set forth in Article 5.

8.07 *Change Orders*

A. Owner is obligated to execute Change Orders as indicated in Paragraph 10.03.

8.08 *Inspections, Tests, and Approvals*

A. Owner's responsibility with respect to certain inspections, tests, and approvals is set forth in Paragraph 13.03.B.

8.09 *Limitations on Owner's Responsibilities*

A. The Owner shall not supervise, direct, or have control or authority over, nor be responsible for, Contractor's means, methods, techniques, sequences, or procedures of construction, or the safety precautions and programs incident thereto, or for any failure of Contractor to comply with Laws and Regulations applicable to the performance of the Work. Owner will not be responsible for Contractor's failure to perform the Work in accordance with the Contract Documents.

8.10 *Undisclosed Hazardous Environmental Condition*

A. Owner's responsibility in respect to an undisclosed Hazardous Environmental Condition is set forth in Paragraph 4.06.

8.11 *Evidence of Financial Arrangements*

A. Upon request of Contractor, Owner shall furnish Contractor reasonable evidence that financial arrangements have been made to satisfy Owner's obligations under the Contract Documents.

8.12 *Compliance with Safety Program*

A. While at the Site, Owner's employees and representatives shall comply with the specific applicable requirements of Contractor's safety programs of which Owner has been informed pursuant to Paragraph 6.13.D.

ARTICLE 9 – ENGINEER'S STATUS DURING CONSTRUCTION

9.01 *Owner's Representative*

A. Engineer will be Owner's representative during the construction period. The duties and responsibilities and the limitations of authority of Engineer as Owner's representative during construction are set forth in the Contract Documents.

9.02 *Visits to Site*

A. Engineer will make visits to the Site at intervals appropriate to the various stages of construction as Engineer deems necessary in order to observe as an experienced and qualified design professional the progress that has been made and the quality of the various aspects of Contractor's executed Work. Based on information obtained during such visits and observations, Engineer, for the benefit of Owner, will determine, in general, if the Work is proceeding in accordance with the Contract Documents. Engineer will not be required to make exhaustive or

continuous inspections on the Site to check the quality or quantity of the Work. Engineer's efforts will be directed toward providing for Owner a greater degree of confidence that the completed Work will conform generally to the Contract Documents. On the basis of such visits and observations, Engineer will keep Owner informed of the progress of the Work and will endeavor to guard Owner against defective Work.

- B. Engineer's visits and observations are subject to all the limitations on Engineer's authority and responsibility set forth in Paragraph 9.09. Particularly, but without limitation, during or as a result of Engineer's visits or observations of Contractor's Work, Engineer will not supervise, direct, control, or have authority over or be responsible for Contractor's means, methods, techniques, sequences, or procedures of construction, or the safety precautions and programs incident thereto, or for any failure of Contractor to comply with Laws and Regulations applicable to the performance of the Work.

9.03 *Project Representative*

- A. If Owner and Engineer agree, Engineer will furnish a Resident Project Representative to assist Engineer in providing more extensive observation of the Work. The authority and responsibilities of any such Resident Project Representative and assistants will be as provided in the Supplementary Conditions, and limitations on the responsibilities thereof will be as provided in Paragraph 9.09. If Owner designates another representative or agent to represent Owner at the Site who is not Engineer's consultant, agent or employee, the responsibilities and authority and limitations thereon of such other individual or entity will be as provided in the Supplementary Conditions.

9.04 *Authorized Variations in Work*

- A. Engineer may authorize minor variations in the Work from the requirements of the Contract Documents which do not involve an adjustment in the Contract Price or the Contract Times and are compatible with the design concept of the completed Project as a functioning whole as indicated by the Contract Documents. These may be accomplished by a Field Order and will be binding on Owner and also on Contractor, who shall perform the Work involved promptly. If Owner or Contractor believes that a Field Order justifies an adjustment in the Contract Price or Contract Times, or both, and the parties are unable to agree on entitlement to or on the amount or extent, if any, of any such adjustment, a Claim may be made therefor as provided in Paragraph 10.05.

9.05 *Rejecting Defective Work*

- A. Engineer will have authority to reject Work which Engineer believes to be defective, or that Engineer believes will not produce a completed Project that conforms to the Contract Documents or that will prejudice the integrity of the design concept of the completed Project as a functioning whole as indicated by the Contract Documents. Engineer will also have authority to require special inspection or testing of the Work as provided in Paragraph 13.04, whether or not the Work is fabricated, installed, or completed.

9.06 *Shop Drawings, Change Orders and Payments*

- A. In connection with Engineer's authority, and limitations thereof, as to Shop Drawings and Samples, see Paragraph 6.17.
- B. In connection with Engineer's authority, and limitations thereof, as to design calculations and design drawings submitted in response to a delegation of professional design services, if any, see Paragraph 6.21.
- C. In connection with Engineer's authority as to Change Orders, see Articles 10, 11, and 12.
- D. In connection with Engineer's authority as to Applications for Payment, see Article 14.

9.07 *Determinations for Unit Price Work*

- A. Engineer will determine the actual quantities and classifications of Unit Price Work performed by Contractor. Engineer will review with Contractor the Engineer's preliminary determinations on such matters before rendering a written decision thereon (by recommendation of an Application for Payment or otherwise). Engineer's written decision thereon will be final and binding (except as modified by Engineer to reflect changed factual conditions or more accurate data) upon Owner and Contractor, subject to the provisions of Paragraph 10.05.

9.08 *Decisions on Requirements of Contract Documents and Acceptability of Work*

- A. Engineer will be the initial interpreter of the requirements of the Contract Documents and judge of the acceptability of the Work thereunder. All matters in question and other matters between Owner and Contractor arising prior to the date final payment is due relating to the acceptability of the Work, and the interpretation of the requirements of the Contract Documents pertaining to the performance of the Work, will be referred initially to Engineer in writing within 30 days of the event giving rise to the question.
- B. Engineer will, with reasonable promptness, render a written decision on the issue referred. If Owner or Contractor believes that any such decision entitles them to an adjustment in the Contract Price or Contract Times or both, a Claim may be made under Paragraph 10.05. The date of Engineer's decision shall be the date of the event giving rise to the issues referenced for the purposes of Paragraph 10.05.B.
- C. Engineer's written decision on the issue referred will be final and binding on Owner and Contractor, subject to the provisions of Paragraph 10.05.
- D. When functioning as interpreter and judge under this Paragraph 9.08, Engineer will not show partiality to Owner or Contractor and will not be liable in connection with any interpretation or decision rendered in good faith in such capacity.

9.09 *Limitations on Engineer's Authority and Responsibilities*

- A. Neither Engineer's authority or responsibility under this Article 9 or under any other provision of the Contract Documents nor any decision made by Engineer in good faith either to exercise or not

exercise such authority or responsibility or the undertaking, exercise, or performance of any authority or responsibility by Engineer shall create, impose, or give rise to any duty in contract, tort, or otherwise owed by Engineer to Contractor, any Subcontractor, any Supplier, any other individual or entity, or to any surety for or employee or agent of any of them.

- B. Engineer will not supervise, direct, control, or have authority over or be responsible for Contractor's means, methods, techniques, sequences, or procedures of construction, or the safety precautions and programs incident thereto, or for any failure of Contractor to comply with Laws and Regulations applicable to the performance of the Work. Engineer will not be responsible for Contractor's failure to perform the Work in accordance with the Contract Documents.
- C. Engineer will not be responsible for the acts or omissions of Contractor or of any Subcontractor, any Supplier, or of any other individual or entity performing any of the Work.
- D. Engineer's review of the final Application for Payment and accompanying documentation and all maintenance and operating instructions, schedules, guarantees, bonds, certificates of inspection, tests and approvals, and other documentation required to be delivered by Paragraph 14.07.A will only be to determine generally that their content complies with the requirements of, and in the case of certificates of inspections, tests, and approvals that the results certified indicate compliance with, the Contract Documents.
- E. The limitations upon authority and responsibility set forth in this Paragraph 9.09 shall also apply to the Resident Project Representative, if any, and assistants, if any.

9.10 *Compliance with Safety Program*

- A. While at the Site, Engineer's employees and representatives shall comply with the specific applicable requirements of Contractor's safety programs of which Engineer has been informed pursuant to Paragraph 6.13.D.

ARTICLE 10 – CHANGES IN THE WORK; CLAIMS

10.01 *Authorized Changes in the Work*

- A. Without invalidating the Contract and without notice to any surety, Owner may, at any time or from time to time, order additions, deletions, or revisions in the Work by a Change Order, or a Work Change Directive. Upon receipt of any such document, Contractor shall promptly proceed with the Work involved which will be performed under the applicable conditions of the Contract Documents (except as otherwise specifically provided).
- B. If Owner and Contractor are unable to agree on entitlement to, or on the amount or extent, if any, of an adjustment in the Contract Price or Contract Times, or both, that should be allowed as a result of a Work Change Directive, a Claim may be made therefor as provided in Paragraph 10.05.

10.02 *Unauthorized Changes in the Work*

- A. Contractor shall not be entitled to an increase in the Contract Price or an extension of the Contract Times with respect to any work performed that is not required by the Contract Documents as amended, modified, or supplemented as provided in Paragraph 3.04, except in the case of an emergency as provided in Paragraph 6.16 or in the case of uncovering Work as provided in Paragraph 13.04.D.

10.03 *Execution of Change Orders*

- A. Owner and Contractor shall execute appropriate Change Orders recommended by Engineer covering:
 - 1. changes in the Work which are: (i) ordered by Owner pursuant to Paragraph 10.01.A, (ii) required because of acceptance of defective Work under Paragraph 13.08.A or Owner's correction of defective Work under Paragraph 13.09, or (iii) agreed to by the parties;
 - 2. changes in the Contract Price or Contract Times which are agreed to by the parties, including any undisputed sum or amount of time for Work actually performed in accordance with a Work Change Directive; and
 - 3. changes in the Contract Price or Contract Times which embody the substance of any written decision rendered by Engineer pursuant to Paragraph 10.05; provided that, in lieu of executing any such Change Order, an appeal may be taken from any such decision in accordance with the provisions of the Contract Documents and applicable Laws and Regulations, but during any such appeal, Contractor shall carry on the Work and adhere to the Progress Schedule as provided in Paragraph 6.18.A.

10.04 *Notification to Surety*

- A. If the provisions of any bond require notice to be given to a surety of any change affecting the general scope of the Work or the provisions of the Contract Documents (including, but not limited to, Contract Price or Contract Times), the giving of any such notice will be Contractor's responsibility. The amount of each applicable bond will be adjusted to reflect the effect of any such change.

10.05 *Claims*

- A. *Engineer's Decision Required:* All Claims, except those waived pursuant to Paragraph 14.09, shall be referred to the Engineer for decision. A decision by Engineer shall be required as a condition precedent to any exercise by Owner or Contractor of any rights or remedies either may otherwise have under the Contract Documents or by Laws and Regulations in respect of such Claims.
- B. *Notice:* Written notice stating the general nature of each Claim shall be delivered by the claimant to Engineer and the other party to the Contract promptly (but in no event later than 30 days) after the start of the event giving rise thereto. The responsibility to substantiate a Claim shall rest with the party making the Claim. Notice of the amount or extent of the Claim, with supporting data

shall be delivered to the Engineer and the other party to the Contract within 60 days after the start of such event (unless Engineer allows additional time for claimant to submit additional or more accurate data in support of such Claim). A Claim for an adjustment in Contract Price shall be prepared in accordance with the provisions of Paragraph 12.01.B. A Claim for an adjustment in Contract Times shall be prepared in accordance with the provisions of Paragraph 12.02.B. Each Claim shall be accompanied by claimant's written statement that the adjustment claimed is the entire adjustment to which the claimant believes it is entitled as a result of said event. The opposing party shall submit any response to Engineer and the claimant within 30 days after receipt of the claimant's last submittal (unless Engineer allows additional time).

- C. *Engineer's Action:* Engineer will review each Claim and, within 30 days after receipt of the last submittal of the claimant or the last submittal of the opposing party, if any, take one of the following actions in writing:
1. deny the Claim in whole or in part;
 2. approve the Claim; or
 3. notify the parties that the Engineer is unable to resolve the Claim if, in the Engineer's sole discretion, it would be inappropriate for the Engineer to do so. For purposes of further resolution of the Claim, such notice shall be deemed a denial.
- D. In the event that Engineer does not take action on a Claim within said 30 days, the Claim shall be deemed denied.
- E. Engineer's written action under Paragraph 10.05.C or denial pursuant to Paragraphs 10.05.C.3 or 10.05.D will be final and binding upon Owner and Contractor, unless Owner or Contractor invoke the dispute resolution procedure set forth in Article 16 within 30 days of such action or denial.
- F. No Claim for an adjustment in Contract Price or Contract Times will be valid if not submitted in accordance with this Paragraph 10.05.

ARTICLE 11 – COST OF THE WORK; ALLOWANCES; UNIT PRICE WORK

11.01 *Cost of the Work*

- A. *Costs Included:* The term Cost of the Work means the sum of all costs, except those excluded in Paragraph 11.01.B, necessarily incurred and paid by Contractor in the proper performance of the Work. When the value of any Work covered by a Change Order or when a Claim for an adjustment in Contract Price is determined on the basis of Cost of the Work, the costs to be reimbursed to Contractor will be only those additional or incremental costs required because of the change in the Work or because of the event giving rise to the Claim. Except as otherwise may be agreed to in writing by Owner, such costs shall be in amounts no higher than those prevailing in the locality of the Project, shall not include any of the costs itemized in Paragraph 11.01.B, and shall include only the following items:

1. Payroll costs for employees in the direct employ of Contractor in the performance of the Work under schedules of job classifications agreed upon by Owner and Contractor. Such employees shall include, without limitation, superintendents, foremen, and other personnel employed full time on the Work. Payroll costs for employees not employed full time on the Work shall be apportioned on the basis of their time spent on the Work. Payroll costs shall include, but not be limited to, salaries and wages plus the cost of fringe benefits, which shall include social security contributions, unemployment, excise, and payroll taxes, workers' compensation, health and retirement benefits, bonuses, sick leave, vacation and holiday pay applicable thereto. The expenses of performing Work outside of regular working hours, on Saturday, Sunday, or legal holidays, shall be included in the above to the extent authorized by Owner.
2. Cost of all materials and equipment furnished and incorporated in the Work, including costs of transportation and storage thereof, and Suppliers' field services required in connection therewith. All cash discounts shall accrue to Contractor unless Owner deposits funds with Contractor with which to make payments, in which case the cash discounts shall accrue to Owner. All trade discounts, rebates and refunds and returns from sale of surplus materials and equipment shall accrue to Owner, and Contractor shall make provisions so that they may be obtained.
3. Payments made by Contractor to Subcontractors for Work performed by Subcontractors. If required by Owner, Contractor shall obtain competitive bids from subcontractors acceptable to Owner and Contractor and shall deliver such bids to Owner, who will then determine, with the advice of Engineer, which bids, if any, will be acceptable. If any subcontract provides that the Subcontractor is to be paid on the basis of Cost of the Work plus a fee, the Subcontractor's Cost of the Work and fee shall be determined in the same manner as Contractor's Cost of the Work and fee as provided in this Paragraph 11.01.
4. Costs of special consultants (including but not limited to engineers, architects, testing laboratories, surveyors, attorneys, and accountants) employed for services specifically related to the Work.
5. Supplemental costs including the following:
 - a. The proportion of necessary transportation, travel, and subsistence expenses of Contractor's employees incurred in discharge of duties connected with the Work.
 - b. Cost, including transportation and maintenance, of all materials, supplies, equipment, machinery, appliances, office, and temporary facilities at the Site, and hand tools not owned by the workers, which are consumed in the performance of the Work, and cost, less market value, of such items used but not consumed which remain the property of Contractor.
 - c. Rentals of all construction equipment and machinery, and the parts thereof whether rented from Contractor or others in accordance with rental agreements approved by Owner with the advice of Engineer, and the costs of transportation, loading, unloading, assembly, dismantling, and removal thereof. All such costs shall be in accordance with the terms of

said rental agreements. The rental of any such equipment, machinery, or parts shall cease when the use thereof is no longer necessary for the Work.

- d. Sales, consumer, use, and other similar taxes related to the Work, and for which Contractor is liable, as imposed by Laws and Regulations.
- e. Deposits lost for causes other than negligence of Contractor, any Subcontractor, or anyone directly or indirectly employed by any of them or for whose acts any of them may be liable, and royalty payments and fees for permits and licenses.
- f. Losses and damages (and related expenses) caused by damage to the Work, not compensated by insurance or otherwise, sustained by Contractor in connection with the performance of the Work (except losses and damages within the deductible amounts of property insurance established in accordance with Paragraph 5.06.D), provided such losses and damages have resulted from causes other than the negligence of Contractor, any Subcontractor, or anyone directly or indirectly employed by any of them or for whose acts any of them may be liable. Such losses shall include settlements made with the written consent and approval of Owner. No such losses, damages, and expenses shall be included in the Cost of the Work for the purpose of determining Contractor's fee.
- g. The cost of utilities, fuel, and sanitary facilities at the Site.
- h. Minor expenses such as telegrams, long distance telephone calls, telephone service at the Site, express and courier services, and similar petty cash items in connection with the Work.
- i. The costs of premiums for all bonds and insurance Contractor is required by the Contract Documents to purchase and maintain.

B. *Costs Excluded:* The term Cost of the Work shall not include any of the following items:

1. Payroll costs and other compensation of Contractor's officers, executives, principals (of partnerships and sole proprietorships), general managers, safety managers, engineers, architects, estimators, attorneys, auditors, accountants, purchasing and contracting agents, expeditors, timekeepers, clerks, and other personnel employed by Contractor, whether at the Site or in Contractor's principal or branch office for general administration of the Work and not specifically included in the agreed upon schedule of job classifications referred to in Paragraph 11.01.A.1 or specifically covered by Paragraph 11.01.A.4, all of which are to be considered administrative costs covered by the Contractor's fee.
2. Expenses of Contractor's principal and branch offices other than Contractor's office at the Site.
3. Any part of Contractor's capital expenses, including interest on Contractor's capital employed for the Work and charges against Contractor for delinquent payments.
4. Costs due to the negligence of Contractor, any Subcontractor, or anyone directly or indirectly employed by any of them or for whose acts any of them may be liable, including but not

limited to, the correction of defective Work, disposal of materials or equipment wrongly supplied, and making good any damage to property.

5. Other overhead or general expense costs of any kind and the costs of any item not specifically and expressly included in Paragraphs 11.01.A.
- C. *Contractor's Fee:* When all the Work is performed on the basis of cost-plus, Contractor's fee shall be determined as set forth in the Agreement. When the value of any Work covered by a Change Order or when a Claim for an adjustment in Contract Price is determined on the basis of Cost of the Work, Contractor's fee shall be determined as set forth in Paragraph 12.01.C.
- D. *Documentation:* Whenever the Cost of the Work for any purpose is to be determined pursuant to Paragraphs 11.01.A and 11.01.B, Contractor will establish and maintain records thereof in accordance with generally accepted accounting practices and submit in a form acceptable to Engineer an itemized cost breakdown together with supporting data.

11.02 Allowances

- A. It is understood that Contractor has included in the Contract Price all allowances so named in the Contract Documents and shall cause the Work so covered to be performed for such sums and by such persons or entities as may be acceptable to Owner and Engineer.
- B. *Cash Allowances:*
 1. Contractor agrees that:
 - a. the cash allowances include the cost to Contractor (less any applicable trade discounts) of materials and equipment required by the allowances to be delivered at the Site, and all applicable taxes; and
 - b. Contractor's costs for unloading and handling on the Site, labor, installation, overhead, profit, and other expenses contemplated for the cash allowances have been included in the Contract Price and not in the allowances, and no demand for additional payment on account of any of the foregoing will be valid.
- C. *Contingency Allowance:*
 1. Contractor agrees that a contingency allowance, if any, is for the sole use of Owner to cover unanticipated costs.
- D. Prior to final payment, an appropriate Change Order will be issued as recommended by Engineer to reflect actual amounts due Contractor on account of Work covered by allowances, and the Contract Price shall be correspondingly adjusted.

11.03 Unit Price Work

- A. Where the Contract Documents provide that all or part of the Work is to be Unit Price Work, initially the Contract Price will be deemed to include for all Unit Price Work an amount equal to

the sum of the unit price for each separately identified item of Unit Price Work times the estimated quantity of each item as indicated in the Agreement.

- B. The estimated quantities of items of Unit Price Work are not guaranteed and are solely for the purpose of comparison of Bids and determining an initial Contract Price. Determinations of the actual quantities and classifications of Unit Price Work performed by Contractor will be made by Engineer subject to the provisions of Paragraph 9.07.
- C. Each unit price will be deemed to include an amount considered by Contractor to be adequate to cover Contractor's overhead and profit for each separately identified item.
- D. Owner or Contractor may make a Claim for an adjustment in the Contract Price in accordance with Paragraph 10.05 if:
 - 1. the quantity of any item of Unit Price Work performed by Contractor differs materially and significantly from the estimated quantity of such item indicated in the Agreement; and
 - 2. there is no corresponding adjustment with respect to any other item of Work; and
 - 3. Contractor believes that Contractor is entitled to an increase in Contract Price as a result of having incurred additional expense or Owner believes that Owner is entitled to a decrease in Contract Price and the parties are unable to agree as to the amount of any such increase or decrease.

ARTICLE 12 – CHANGE OF CONTRACT PRICE; CHANGE OF CONTRACT TIMES

12.01 Change of Contract Price

- A. The Contract Price may only be changed by a Change Order. Any Claim for an adjustment in the Contract Price shall be based on written notice submitted by the party making the Claim to the Engineer and the other party to the Contract in accordance with the provisions of Paragraph 10.05.
- B. The value of any Work covered by a Change Order or of any Claim for an adjustment in the Contract Price will be determined as follows:
 - 1. where the Work involved is covered by unit prices contained in the Contract Documents, by application of such unit prices to the quantities of the items involved (subject to the provisions of Paragraph 11.03); or
 - 2. where the Work involved is not covered by unit prices contained in the Contract Documents, by a mutually agreed lump sum (which may include an allowance for overhead and profit not necessarily in accordance with Paragraph 12.01.C.2); or
 - 3. where the Work involved is not covered by unit prices contained in the Contract Documents and agreement to a lump sum is not reached under Paragraph 12.01.B.2, on the basis of the Cost of the Work (determined as provided in Paragraph 11.01) plus a Contractor's fee for overhead and profit (determined as provided in Paragraph 12.01.C).

C. *Contractor's Fee*: The Contractor's fee for overhead and profit shall be determined as follows:

1. a mutually acceptable fixed fee; or
2. if a fixed fee is not agreed upon, then a fee based on the following percentages of the various portions of the Cost of the Work:
 - a. for costs incurred under Paragraphs 11.01.A.1 and 11.01.A.2, the Contractor's fee shall be 15 percent;
 - b. for costs incurred under Paragraph 11.01.A.3, the Contractor's fee shall be five percent;
 - c. where one or more tiers of subcontracts are on the basis of Cost of the Work plus a fee and no fixed fee is agreed upon, the intent of Paragraphs 12.01.C.2.a and 12.01.C.2.b is that the Subcontractor who actually performs the Work, at whatever tier, will be paid a fee of 15 percent of the costs incurred by such Subcontractor under Paragraphs 11.01.A.1 and 11.01.A.2 and that any higher tier Subcontractor and Contractor will each be paid a fee of five percent of the amount paid to the next lower tier Subcontractor;
 - d. no fee shall be payable on the basis of costs itemized under Paragraphs 11.01.A.4, 11.01.A.5, and 11.01.B;
 - e. the amount of credit to be allowed by Contractor to Owner for any change which results in a net decrease in cost will be the amount of the actual net decrease in cost plus a deduction in Contractor's fee by an amount equal to five percent of such net decrease; and
 - f. when both additions and credits are involved in any one change, the adjustment in Contractor's fee shall be computed on the basis of the net change in accordance with Paragraphs 12.01.C.2.a through 12.01.C.2.e, inclusive.

12.02 *Change of Contract Times*

- A. The Contract Times may only be changed by a Change Order. Any Claim for an adjustment in the Contract Times shall be based on written notice submitted by the party making the Claim to the Engineer and the other party to the Contract in accordance with the provisions of Paragraph 10.05.
- B. Any adjustment of the Contract Times covered by a Change Order or any Claim for an adjustment in the Contract Times will be determined in accordance with the provisions of this Article 12.

12.03 *Delays*

- A. Where Contractor is prevented from completing any part of the Work within the Contract Times due to delay beyond the control of Contractor, the Contract Times will be extended in an amount equal to the time lost due to such delay if a Claim is made therefor as provided in Paragraph 12.02.A. Delays beyond the control of Contractor shall include, but not be limited to, acts or

neglect by Owner, acts or neglect of utility owners or other contractors performing other work as contemplated by Article 7, fires, floods, epidemics, abnormal weather conditions, or acts of God.

- B. If Owner, Engineer, or other contractors or utility owners performing other work for Owner as contemplated by Article 7, or anyone for whom Owner is responsible, delays, disrupts, or interferes with the performance or progress of the Work, then Contractor shall be entitled to an equitable adjustment in the Contract Price or the Contract Times, or both. Contractor's entitlement to an adjustment of the Contract Times is conditioned on such adjustment being essential to Contractor's ability to complete the Work within the Contract Times.
- C. If Contractor is delayed in the performance or progress of the Work by fire, flood, epidemic, abnormal weather conditions, acts of God, acts or failures to act of utility owners not under the control of Owner, or other causes not the fault of and beyond control of Owner and Contractor, then Contractor shall be entitled to an equitable adjustment in Contract Times, if such adjustment is essential to Contractor's ability to complete the Work within the Contract Times. Such an adjustment shall be Contractor's sole and exclusive remedy for the delays described in this Paragraph 12.03.C.
- D. Owner, Engineer, and their officers, directors, members, partners, employees, agents, consultants, or subcontractors shall not be liable to Contractor for any claims, costs, losses, or damages (including but not limited to all fees and charges of engineers, architects, attorneys, and other professionals and all court or arbitration or other dispute resolution costs) sustained by Contractor on or in connection with any other project or anticipated project.
- E. Contractor shall not be entitled to an adjustment in Contract Price or Contract Times for delays within the control of Contractor. Delays attributable to and within the control of a Subcontractor or Supplier shall be deemed to be delays within the control of Contractor.

ARTICLE 13 – TESTS AND INSPECTIONS; CORRECTION, REMOVAL OR ACCEPTANCE OF DEFECTIVE WORK

13.01 Notice of Defects

- A. Prompt notice of all defective Work of which Owner or Engineer has actual knowledge will be given to Contractor. Defective Work may be rejected, corrected, or accepted as provided in this Article 13.

13.02 Access to Work

- A. Owner, Engineer, their consultants and other representatives and personnel of Owner, independent testing laboratories, and governmental agencies with jurisdictional interests will have access to the Site and the Work at reasonable times for their observation, inspection, and testing. Contractor shall provide them proper and safe conditions for such access and advise them of Contractor's safety procedures and programs so that they may comply therewith as applicable.

13.03 *Tests and Inspections*

- A. Contractor shall give Engineer timely notice of readiness of the Work for all required inspections, tests, or approvals and shall cooperate with inspection and testing personnel to facilitate required inspections or tests.
- B. Owner shall employ and pay for the services of an independent testing laboratory to perform all inspections, tests, or approvals required by the Contract Documents except:
 - 1. for inspections, tests, or approvals covered by Paragraphs 13.03.C and 13.03.D below;
 - 2. that costs incurred in connection with tests or inspections conducted pursuant to Paragraph 13.04.B shall be paid as provided in Paragraph 13.04.C; and
 - 3. as otherwise specifically provided in the Contract Documents.
- C. If Laws or Regulations of any public body having jurisdiction require any Work (or part thereof) specifically to be inspected, tested, or approved by an employee or other representative of such public body, Contractor shall assume full responsibility for arranging and obtaining such inspections, tests, or approvals, pay all costs in connection therewith, and furnish Engineer the required certificates of inspection or approval.
- D. Contractor shall be responsible for arranging and obtaining and shall pay all costs in connection with any inspections, tests, or approvals required for Owner's and Engineer's acceptance of materials or equipment to be incorporated in the Work; or acceptance of materials, mix designs, or equipment submitted for approval prior to Contractor's purchase thereof for incorporation in the Work. Such inspections, tests, or approvals shall be performed by organizations acceptable to Owner and Engineer.
- E. If any Work (or the work of others) that is to be inspected, tested, or approved is covered by Contractor without written concurrence of Engineer, Contractor shall, if requested by Engineer, uncover such Work for observation.
- F. Uncovering Work as provided in Paragraph 13.03.E shall be at Contractor's expense unless Contractor has given Engineer timely notice of Contractor's intention to cover the same and Engineer has not acted with reasonable promptness in response to such notice.

13.04 *Uncovering Work*

- A. If any Work is covered contrary to the written request of Engineer, it must, if requested by Engineer, be uncovered for Engineer's observation and replaced at Contractor's expense.
- B. If Engineer considers it necessary or advisable that covered Work be observed by Engineer or inspected or tested by others, Contractor, at Engineer's request, shall uncover, expose, or otherwise make available for observation, inspection, or testing as Engineer may require, that portion of the Work in question, furnishing all necessary labor, material, and equipment.

- C. If it is found that the uncovered Work is defective, Contractor shall pay all claims, costs, losses, and damages (including but not limited to all fees and charges of engineers, architects, attorneys, and other professionals and all court or arbitration or other dispute resolution costs) arising out of or relating to such uncovering, exposure, observation, inspection, and testing, and of satisfactory replacement or reconstruction (including but not limited to all costs of repair or replacement of work of others); and Owner shall be entitled to an appropriate decrease in the Contract Price. If the parties are unable to agree as to the amount thereof, Owner may make a Claim therefor as provided in Paragraph 10.05.
- D. If the uncovered Work is not found to be defective, Contractor shall be allowed an increase in the Contract Price or an extension of the Contract Times, or both, directly attributable to such uncovering, exposure, observation, inspection, testing, replacement, and reconstruction. If the parties are unable to agree as to the amount or extent thereof, Contractor may make a Claim therefor as provided in Paragraph 10.05.

13.05 *Owner May Stop the Work*

- A. If the Work is defective, or Contractor fails to supply sufficient skilled workers or suitable materials or equipment, or fails to perform the Work in such a way that the completed Work will conform to the Contract Documents, Owner may order Contractor to stop the Work, or any portion thereof, until the cause for such order has been eliminated; however, this right of Owner to stop the Work shall not give rise to any duty on the part of Owner to exercise this right for the benefit of Contractor, any Subcontractor, any Supplier, any other individual or entity, or any surety for, or employee or agent of any of them.

13.06 *Correction or Removal of Defective Work*

- A. Promptly after receipt of written notice, Contractor shall correct all defective Work, whether or not fabricated, installed, or completed, or, if the Work has been rejected by Engineer, remove it from the Project and replace it with Work that is not defective. Contractor shall pay all claims, costs, losses, and damages (including but not limited to all fees and charges of engineers, architects, attorneys, and other professionals and all court or arbitration or other dispute resolution costs) arising out of or relating to such correction or removal (including but not limited to all costs of repair or replacement of work of others).
- B. When correcting defective Work under the terms of this Paragraph 13.06 or Paragraph 13.07, Contractor shall take no action that would void or otherwise impair Owner's special warranty and guarantee, if any, on said Work.

13.07 *Correction Period*

- A. If within one year after the date of Substantial Completion (or such longer period of time as may be prescribed by the terms of any applicable special guarantee required by the Contract Documents) or by any specific provision of the Contract Documents, any Work is found to be defective, or if the repair of any damages to the land or areas made available for Contractor's use by Owner or permitted by Laws and Regulations as contemplated in Paragraph 6.11.A is found to be defective, Contractor shall promptly, without cost to Owner and in accordance with Owner's written instructions:

1. repair such defective land or areas; or
 2. correct such defective Work; or
 3. if the defective Work has been rejected by Owner, remove it from the Project and replace it with Work that is not defective, and
 4. satisfactorily correct or repair or remove and replace any damage to other Work, to the work of others or other land or areas resulting therefrom.
- B. If Contractor does not promptly comply with the terms of Owner's written instructions, or in an emergency where delay would cause serious risk of loss or damage, Owner may have the defective Work corrected or repaired or may have the rejected Work removed and replaced. All claims, costs, losses, and damages (including but not limited to all fees and charges of engineers, architects, attorneys, and other professionals and all court or arbitration or other dispute resolution costs) arising out of or relating to such correction or repair or such removal and replacement (including but not limited to all costs of repair or replacement of work of others) will be paid by Contractor.
- C. In special circumstances where a particular item of equipment is placed in continuous service before Substantial Completion of all the Work, the correction period for that item may start to run from an earlier date if so provided in the Specifications.
- D. Where defective Work (and damage to other Work resulting therefrom) has been corrected or removed and replaced under this Paragraph 13.07, the correction period hereunder with respect to such Work will be extended for an additional period of one year after such correction or removal and replacement has been satisfactorily completed.
- E. Contractor's obligations under this Paragraph 13.07 are in addition to any other obligation or warranty. The provisions of this Paragraph 13.07 shall not be construed as a substitute for, or a waiver of, the provisions of any applicable statute of limitation or repose.

13.08 *Acceptance of Defective Work*

- A. If, instead of requiring correction or removal and replacement of defective Work, Owner (and, prior to Engineer's recommendation of final payment, Engineer) prefers to accept it, Owner may do so. Contractor shall pay all claims, costs, losses, and damages (including but not limited to all fees and charges of engineers, architects, attorneys, and other professionals and all court or arbitration or other dispute resolution costs) attributable to Owner's evaluation of and determination to accept such defective Work (such costs to be approved by Engineer as to reasonableness) and for the diminished value of the Work to the extent not otherwise paid by Contractor pursuant to this sentence. If any such acceptance occurs prior to Engineer's recommendation of final payment, a Change Order will be issued incorporating the necessary revisions in the Contract Documents with respect to the Work, and Owner shall be entitled to an appropriate decrease in the Contract Price, reflecting the diminished value of Work so accepted. If the parties are unable to agree as to the amount thereof, Owner may make a Claim therefor as provided in Paragraph 10.05. If the acceptance occurs after such recommendation, an appropriate amount will be paid by Contractor to Owner.

13.09 *Owner May Correct Defective Work*

- A. If Contractor fails within a reasonable time after written notice from Engineer to correct defective Work, or to remove and replace rejected Work as required by Engineer in accordance with Paragraph 13.06.A, or if Contractor fails to perform the Work in accordance with the Contract Documents, or if Contractor fails to comply with any other provision of the Contract Documents, Owner may, after seven days written notice to Contractor, correct, or remedy any such deficiency.
- B. In exercising the rights and remedies under this Paragraph 13.09, Owner shall proceed expeditiously. In connection with such corrective or remedial action, Owner may exclude Contractor from all or part of the Site, take possession of all or part of the Work and suspend Contractor's services related thereto, take possession of Contractor's tools, appliances, construction equipment and machinery at the Site, and incorporate in the Work all materials and equipment stored at the Site or for which Owner has paid Contractor but which are stored elsewhere. Contractor shall allow Owner, Owner's representatives, agents and employees, Owner's other contractors, and Engineer and Engineer's consultants access to the Site to enable Owner to exercise the rights and remedies under this Paragraph.
- C. All claims, costs, losses, and damages (including but not limited to all fees and charges of engineers, architects, attorneys, and other professionals and all court or arbitration or other dispute resolution costs) incurred or sustained by Owner in exercising the rights and remedies under this Paragraph 13.09 will be charged against Contractor, and a Change Order will be issued incorporating the necessary revisions in the Contract Documents with respect to the Work; and Owner shall be entitled to an appropriate decrease in the Contract Price. If the parties are unable to agree as to the amount of the adjustment, Owner may make a Claim therefor as provided in Paragraph 10.05. Such claims, costs, losses and damages will include but not be limited to all costs of repair, or replacement of work of others destroyed or damaged by correction, removal, or replacement of Contractor's defective Work.
- D. Contractor shall not be allowed an extension of the Contract Times because of any delay in the performance of the Work attributable to the exercise by Owner of Owner's rights and remedies under this Paragraph 13.09.

ARTICLE 14 – PAYMENTS TO CONTRACTOR AND COMPLETION

14.01 *Schedule of Values*

- A. The Schedule of Values established as provided in Paragraph 2.07.A will serve as the basis for progress payments and will be incorporated into a form of Application for Payment acceptable to Engineer. Progress payments on account of Unit Price Work will be based on the number of units completed.

14.02 *Progress Payments*

A. *Applications for Payments:*

- 1. At least 20 days before the date established in the Agreement for each progress payment (but not more often than once a month), Contractor shall submit to Engineer for review an

Application for Payment filled out and signed by Contractor covering the Work completed as of the date of the Application and accompanied by such supporting documentation as is required by the Contract Documents. If payment is requested on the basis of materials and equipment not incorporated in the Work but delivered and suitably stored at the Site or at another location agreed to in writing, the Application for Payment shall also be accompanied by a bill of sale, invoice, or other documentation warranting that Owner has received the materials and equipment free and clear of all Liens and evidence that the materials and equipment are covered by appropriate property insurance or other arrangements to protect Owner's interest therein, all of which must be satisfactory to Owner.

2. Beginning with the second Application for Payment, each Application shall include an affidavit of Contractor stating that all previous progress payments received on account of the Work have been applied on account to discharge Contractor's legitimate obligations associated with prior Applications for Payment.
3. The amount of retainage with respect to progress payments will be as stipulated in the Agreement.

B. Review of Applications:

1. Engineer will, within 10 days after receipt of each Application for Payment, either indicate in writing a recommendation of payment and present the Application to Owner or return the Application to Contractor indicating in writing Engineer's reasons for refusing to recommend payment. In the latter case, Contractor may make the necessary corrections and resubmit the Application.
2. Engineer's recommendation of any payment requested in an Application for Payment will constitute a representation by Engineer to Owner, based on Engineer's observations of the executed Work as an experienced and qualified design professional, and on Engineer's review of the Application for Payment and the accompanying data and schedules, that to the best of Engineer's knowledge, information and belief:
 - a. the Work has progressed to the point indicated;
 - b. the quality of the Work is generally in accordance with the Contract Documents (subject to an evaluation of the Work as a functioning whole prior to or upon Substantial Completion, the results of any subsequent tests called for in the Contract Documents, a final determination of quantities and classifications for Unit Price Work under Paragraph 9.07, and any other qualifications stated in the recommendation); and
 - c. the conditions precedent to Contractor's being entitled to such payment appear to have been fulfilled in so far as it is Engineer's responsibility to observe the Work.
3. By recommending any such payment Engineer will not thereby be deemed to have represented that:
 - a. inspections made to check the quality or the quantity of the Work as it has been performed have been exhaustive, extended to every aspect of the Work in progress, or

- involved detailed inspections of the Work beyond the responsibilities specifically assigned to Engineer in the Contract Documents; or
- b. there may not be other matters or issues between the parties that might entitle Contractor to be paid additionally by Owner or entitle Owner to withhold payment to Contractor.
4. Neither Engineer's review of Contractor's Work for the purposes of recommending payments nor Engineer's recommendation of any payment, including final payment, will impose responsibility on Engineer:
 - a. to supervise, direct, or control the Work, or
 - b. for the means, methods, techniques, sequences, or procedures of construction, or the safety precautions and programs incident thereto, or
 - c. for Contractor's failure to comply with Laws and Regulations applicable to Contractor's performance of the Work, or
 - d. to make any examination to ascertain how or for what purposes Contractor has used the moneys paid on account of the Contract Price, or
 - e. to determine that title to any of the Work, materials, or equipment has passed to Owner free and clear of any Liens.
 5. Engineer may refuse to recommend the whole or any part of any payment if, in Engineer's opinion, it would be incorrect to make the representations to Owner stated in Paragraph 14.02.B.2. Engineer may also refuse to recommend any such payment or, because of subsequently discovered evidence or the results of subsequent inspections or tests, revise or revoke any such payment recommendation previously made, to such extent as may be necessary in Engineer's opinion to protect Owner from loss because:
 - a. the Work is defective, or completed Work has been damaged, requiring correction or replacement;
 - b. the Contract Price has been reduced by Change Orders;
 - c. Owner has been required to correct defective Work or complete Work in accordance with Paragraph 13.09; or
 - d. Engineer has actual knowledge of the occurrence of any of the events enumerated in Paragraph 15.02.A.

C. Payment Becomes Due:

1. Ten days after presentation of the Application for Payment to Owner with Engineer's recommendation, the amount recommended will (subject to the provisions of Paragraph 14.02.D) become due, and when due will be paid by Owner to Contractor.

D. *Reduction in Payment:*

1. Owner may refuse to make payment of the full amount recommended by Engineer because:
 - a. claims have been made against Owner on account of Contractor's performance or furnishing of the Work;
 - b. Liens have been filed in connection with the Work, except where Contractor has delivered a specific bond satisfactory to Owner to secure the satisfaction and discharge of such Liens;
 - c. there are other items entitling Owner to a set-off against the amount recommended; or
 - d. Owner has actual knowledge of the occurrence of any of the events enumerated in Paragraphs 14.02.B.5.a through 14.02.B.5.c or Paragraph 15.02.A.
2. If Owner refuses to make payment of the full amount recommended by Engineer, Owner will give Contractor immediate written notice (with a copy to Engineer) stating the reasons for such action and promptly pay Contractor any amount remaining after deduction of the amount so withheld. Owner shall promptly pay Contractor the amount so withheld, or any adjustment thereto agreed to by Owner and Contractor, when Contractor remedies the reasons for such action.
3. Upon a subsequent determination that Owner's refusal of payment was not justified, the amount wrongfully withheld shall be treated as an amount due as determined by Paragraph 14.02.C.1 and subject to interest as provided in the Agreement.

14.03 *Contractor's Warranty of Title*

- A. Contractor warrants and guarantees that title to all Work, materials, and equipment covered by any Application for Payment, whether incorporated in the Project or not, will pass to Owner no later than the time of payment free and clear of all Liens.

14.04 *Substantial Completion*

- A. When Contractor considers the entire Work ready for its intended use Contractor shall notify Owner and Engineer in writing that the entire Work is substantially complete (except for items specifically listed by Contractor as incomplete) and request that Engineer issue a certificate of Substantial Completion.
- B. Promptly after Contractor's notification, Owner, Contractor, and Engineer shall make an inspection of the Work to determine the status of completion. If Engineer does not consider the Work substantially complete, Engineer will notify Contractor in writing giving the reasons therefor.
- C. If Engineer considers the Work substantially complete, Engineer will deliver to Owner a tentative certificate of Substantial Completion which shall fix the date of Substantial Completion. There shall be attached to the certificate a tentative list of items to be completed or corrected before

final payment. Owner shall have seven days after receipt of the tentative certificate during which to make written objection to Engineer as to any provisions of the certificate or attached list. If, after considering such objections, Engineer concludes that the Work is not substantially complete, Engineer will, within 14 days after submission of the tentative certificate to Owner, notify Contractor in writing, stating the reasons therefor. If, after consideration of Owner's objections, Engineer considers the Work substantially complete, Engineer will, within said 14 days, execute and deliver to Owner and Contractor a definitive certificate of Substantial Completion (with a revised tentative list of items to be completed or corrected) reflecting such changes from the tentative certificate as Engineer believes justified after consideration of any objections from Owner.

- D. At the time of delivery of the tentative certificate of Substantial Completion, Engineer will deliver to Owner and Contractor a written recommendation as to division of responsibilities pending final payment between Owner and Contractor with respect to security, operation, safety, and protection of the Work, maintenance, heat, utilities, insurance, and warranties and guarantees. Unless Owner and Contractor agree otherwise in writing and so inform Engineer in writing prior to Engineer's issuing the definitive certificate of Substantial Completion, Engineer's aforesaid recommendation will be binding on Owner and Contractor until final payment.
- E. Owner shall have the right to exclude Contractor from the Site after the date of Substantial Completion subject to allowing Contractor reasonable access to remove its property and complete or correct items on the tentative list.

14.05 *Partial Utilization*

- A. Prior to Substantial Completion of all the Work, Owner may use or occupy any substantially completed part of the Work which has specifically been identified in the Contract Documents, or which Owner, Engineer, and Contractor agree constitutes a separately functioning and usable part of the Work that can be used by Owner for its intended purpose without significant interference with Contractor's performance of the remainder of the Work, subject to the following conditions:
 - 1. Owner at any time may request Contractor in writing to permit Owner to use or occupy any such part of the Work which Owner believes to be ready for its intended use and substantially complete. If and when Contractor agrees that such part of the Work is substantially complete, Contractor, Owner, and Engineer will follow the procedures of Paragraph 14.04.A through D for that part of the Work.
 - 2. Contractor at any time may notify Owner and Engineer in writing that Contractor considers any such part of the Work ready for its intended use and substantially complete and request Engineer to issue a certificate of Substantial Completion for that part of the Work.
 - 3. Within a reasonable time after either such request, Owner, Contractor, and Engineer shall make an inspection of that part of the Work to determine its status of completion. If Engineer does not consider that part of the Work to be substantially complete, Engineer will notify Owner and Contractor in writing giving the reasons therefor. If Engineer considers that part of the Work to be substantially complete, the provisions of Paragraph 14.04 will apply with respect to certification of Substantial Completion of that part of the Work and the division of responsibility in respect thereof and access thereto.

4. No use or occupancy or separate operation of part of the Work may occur prior to compliance with the requirements of Paragraph 5.10 regarding property insurance.

14.06 *Final Inspection*

- A. Upon written notice from Contractor that the entire Work or an agreed portion thereof is complete, Engineer will promptly make a final inspection with Owner and Contractor and will notify Contractor in writing of all particulars in which this inspection reveals that the Work is incomplete or defective. Contractor shall immediately take such measures as are necessary to complete such Work or remedy such deficiencies.

14.07 *Final Payment*

A. *Application for Payment:*

1. After Contractor has, in the opinion of Engineer, satisfactorily completed all corrections identified during the final inspection and has delivered, in accordance with the Contract Documents, all maintenance and operating instructions, schedules, guarantees, bonds, certificates or other evidence of insurance, certificates of inspection, marked-up record documents (as provided in Paragraph 6.12), and other documents, Contractor may make application for final payment following the procedure for progress payments.
2. The final Application for Payment shall be accompanied (except as previously delivered) by:
 - a. all documentation called for in the Contract Documents, including but not limited to the evidence of insurance required by Paragraph 5.04.B.6;
 - b. consent of the surety, if any, to final payment;
 - c. a list of all Claims against Owner that Contractor believes are unsettled; and
 - d. complete and legally effective releases or waivers (satisfactory to Owner) of all Lien rights arising out of or Liens filed in connection with the Work.
3. In lieu of the releases or waivers of Liens specified in Paragraph 14.07.A.2 and as approved by Owner, Contractor may furnish receipts or releases in full and an affidavit of Contractor that: (i) the releases and receipts include all labor, services, material, and equipment for which a Lien could be filed; and (ii) all payrolls, material and equipment bills, and other indebtedness connected with the Work for which Owner might in any way be responsible, or which might in any way result in liens or other burdens on Owner's property, have been paid or otherwise satisfied. If any Subcontractor or Supplier fails to furnish such a release or receipt in full, Contractor may furnish a bond or other collateral satisfactory to Owner to indemnify Owner against any Lien.

B. *Engineer's Review of Application and Acceptance:*

1. If, on the basis of Engineer's observation of the Work during construction and final inspection, and Engineer's review of the final Application for Payment and accompanying

documentation as required by the Contract Documents, Engineer is satisfied that the Work has been completed and Contractor's other obligations under the Contract Documents have been fulfilled, Engineer will, within ten days after receipt of the final Application for Payment, indicate in writing Engineer's recommendation of payment and present the Application for Payment to Owner for payment. At the same time Engineer will also give written notice to Owner and Contractor that the Work is acceptable subject to the provisions of Paragraph 14.09. Otherwise, Engineer will return the Application for Payment to Contractor, indicating in writing the reasons for refusing to recommend final payment, in which case Contractor shall make the necessary corrections and resubmit the Application for Payment.

C. Payment Becomes Due:

1. Thirty days after the presentation to Owner of the Application for Payment and accompanying documentation, the amount recommended by Engineer, less any sum Owner is entitled to set off against Engineer's recommendation, including but not limited to liquidated damages, will become due and will be paid by Owner to Contractor.

14.08 Final Completion Delayed

- A. If, through no fault of Contractor, final completion of the Work is significantly delayed, and if Engineer so confirms, Owner shall, upon receipt of Contractor's final Application for Payment (for Work fully completed and accepted) and recommendation of Engineer, and without terminating the Contract, make payment of the balance due for that portion of the Work fully completed and accepted. If the remaining balance to be held by Owner for Work not fully completed or corrected is less than the retainage stipulated in the Agreement, and if bonds have been furnished as required in Paragraph 5.01, the written consent of the surety to the payment of the balance due for that portion of the Work fully completed and accepted shall be submitted by Contractor to Engineer with the Application for such payment. Such payment shall be made under the terms and conditions governing final payment, except that it shall not constitute a waiver of Claims.

14.09 Waiver of Claims

- A. The making and acceptance of final payment will constitute:
 1. a waiver of all Claims by Owner against Contractor, except Claims arising from unsettled Liens, from defective Work appearing after final inspection pursuant to Paragraph 14.06, from failure to comply with the Contract Documents or the terms of any special guarantees specified therein, or from Contractor's continuing obligations under the Contract Documents; and
 2. a waiver of all Claims by Contractor against Owner other than those previously made in accordance with the requirements herein and expressly acknowledged by Owner in writing as still unsettled.

ARTICLE 15 – SUSPENSION OF WORK AND TERMINATION

15.01 *Owner May Suspend Work*

- A. At any time and without cause, Owner may suspend the Work or any portion thereof for a period of not more than 90 consecutive days by notice in writing to Contractor and Engineer which will fix the date on which Work will be resumed. Contractor shall resume the Work on the date so fixed. Contractor shall be granted an adjustment in the Contract Price or an extension of the Contract Times, or both, directly attributable to any such suspension if Contractor makes a Claim therefor as provided in Paragraph 10.05.

15.02 *Owner May Terminate for Cause*

- A. The occurrence of any one or more of the following events will justify termination for cause:
 1. Contractor's persistent failure to perform the Work in accordance with the Contract Documents (including, but not limited to, failure to supply sufficient skilled workers or suitable materials or equipment or failure to adhere to the Progress Schedule established under Paragraph 2.07 as adjusted from time to time pursuant to Paragraph 6.04);
 2. Contractor's disregard of Laws or Regulations of any public body having jurisdiction;
 3. Contractor's repeated disregard of the authority of Engineer; or
 4. Contractor's violation in any substantial way of any provisions of the Contract Documents.
- B. If one or more of the events identified in Paragraph 15.02.A occur, Owner may, after giving Contractor (and surety) seven days written notice of its intent to terminate the services of Contractor:
 1. exclude Contractor from the Site, and take possession of the Work and of all Contractor's tools, appliances, construction equipment, and machinery at the Site, and use the same to the full extent they could be used by Contractor (without liability to Contractor for trespass or conversion);
 2. incorporate in the Work all materials and equipment stored at the Site or for which Owner has paid Contractor but which are stored elsewhere; and
 3. complete the Work as Owner may deem expedient.
- C. If Owner proceeds as provided in Paragraph 15.02.B, Contractor shall not be entitled to receive any further payment until the Work is completed. If the unpaid balance of the Contract Price exceeds all claims, costs, losses, and damages (including but not limited to all fees and charges of engineers, architects, attorneys, and other professionals and all court or arbitration or other dispute resolution costs) sustained by Owner arising out of or relating to completing the Work, such excess will be paid to Contractor. If such claims, costs, losses, and damages exceed such unpaid balance, Contractor shall pay the difference to Owner. Such claims, costs, losses, and damages incurred by Owner will be reviewed by Engineer as to their reasonableness and, when

so approved by Engineer, incorporated in a Change Order. When exercising any rights or remedies under this Paragraph, Owner shall not be required to obtain the lowest price for the Work performed.

- D. Notwithstanding Paragraphs 15.02.B and 15.02.C, Contractor's services will not be terminated if Contractor begins within seven days of receipt of notice of intent to terminate to correct its failure to perform and proceeds diligently to cure such failure within no more than 30 days of receipt of said notice.
- E. Where Contractor's services have been so terminated by Owner, the termination will not affect any rights or remedies of Owner against Contractor then existing or which may thereafter accrue. Any retention or payment of moneys due Contractor by Owner will not release Contractor from liability.
- F. If and to the extent that Contractor has provided a performance bond under the provisions of Paragraph 5.01.A, the termination procedures of that bond shall supersede the provisions of Paragraphs 15.02.B and 15.02.C.

15.03 *Owner May Terminate For Convenience*

- A. Upon seven days written notice to Contractor and Engineer, Owner may, without cause and without prejudice to any other right or remedy of Owner, terminate the Contract. In such case, Contractor shall be paid for (without duplication of any items):
 - 1. completed and acceptable Work executed in accordance with the Contract Documents prior to the effective date of termination, including fair and reasonable sums for overhead and profit on such Work;
 - 2. expenses sustained prior to the effective date of termination in performing services and furnishing labor, materials, or equipment as required by the Contract Documents in connection with uncompleted Work, plus fair and reasonable sums for overhead and profit on such expenses;
 - 3. all claims, costs, losses, and damages (including but not limited to all fees and charges of engineers, architects, attorneys, and other professionals and all court or arbitration or other dispute resolution costs) incurred in settlement of terminated contracts with Subcontractors, Suppliers, and others; and
 - 4. reasonable expenses directly attributable to termination.
- B. Contractor shall not be paid on account of loss of anticipated profits or revenue or other economic loss arising out of or resulting from such termination.

15.04 *Contractor May Stop Work or Terminate*

- A. If, through no act or fault of Contractor, (i) the Work is suspended for more than 90 consecutive days by Owner or under an order of court or other public authority, or (ii) Engineer fails to act on any Application for Payment within 30 days after it is submitted, or (iii) Owner fails for 30 days

to pay Contractor any sum finally determined to be due, then Contractor may, upon seven days written notice to Owner and Engineer, and provided Owner or Engineer do not remedy such suspension or failure within that time, terminate the Contract and recover from Owner payment on the same terms as provided in Paragraph 15.03.

- B. In lieu of terminating the Contract and without prejudice to any other right or remedy, if Engineer has failed to act on an Application for Payment within 30 days after it is submitted, or Owner has failed for 30 days to pay Contractor any sum finally determined to be due, Contractor may, seven days after written notice to Owner and Engineer, stop the Work until payment is made of all such amounts due Contractor, including interest thereon. The provisions of this Paragraph 15.04 are not intended to preclude Contractor from making a Claim under Paragraph 10.05 for an adjustment in Contract Price or Contract Times or otherwise for expenses or damage directly attributable to Contractor's stopping the Work as permitted by this Paragraph.

ARTICLE 16 – DISPUTE RESOLUTION

16.01 Methods and Procedures

- A. Either Owner or Contractor may request mediation of any Claim submitted to Engineer for a decision under Paragraph 10.05 before such decision becomes final and binding. The mediation will be governed by the Construction Industry Mediation Rules of the American Arbitration Association in effect as of the Effective Date of the Agreement. The request for mediation shall be submitted in writing to the American Arbitration Association and the other party to the Contract. Timely submission of the request shall stay the effect of Paragraph 10.05.E.
- B. Owner and Contractor shall participate in the mediation process in good faith. The process shall be concluded within 60 days of filing of the request. The date of termination of the mediation shall be determined by application of the mediation rules referenced above.
- C. If the Claim is not resolved by mediation, Engineer's action under Paragraph 10.05.C or a denial pursuant to Paragraphs 10.05.C.3 or 10.05.D shall become final and binding 30 days after termination of the mediation unless, within that time period, Owner or Contractor:
 - 1. elects in writing to invoke any dispute resolution process provided for in the Supplementary Conditions; or
 - 2. agrees with the other party to submit the Claim to another dispute resolution process; or
 - 3. gives written notice to the other party of the intent to submit the Claim to a court of competent jurisdiction.

ARTICLE 17 – MISCELLANEOUS

17.01 Giving Notice

- A. Whenever any provision of the Contract Documents requires the giving of written notice, it will be deemed to have been validly given if:

1. delivered in person to the individual or to a member of the firm or to an officer of the corporation for whom it is intended; or
2. delivered at or sent by registered or certified mail, postage prepaid, to the last business address known to the giver of the notice.

17.02 *Computation of Times*

- A. When any period of time is referred to in the Contract Documents by days, it will be computed to exclude the first and include the last day of such period. If the last day of any such period falls on a Saturday or Sunday or on a day made a legal holiday by the law of the applicable jurisdiction, such day will be omitted from the computation.

17.03 *Cumulative Remedies*

- A. The duties and obligations imposed by these General Conditions and the rights and remedies available hereunder to the parties hereto are in addition to, and are not to be construed in any way as a limitation of, any rights and remedies available to any or all of them which are otherwise imposed or available by Laws or Regulations, by special warranty or guarantee, or by other provisions of the Contract Documents. The provisions of this Paragraph will be as effective as if repeated specifically in the Contract Documents in connection with each particular duty, obligation, right, and remedy to which they apply.

17.04 *Survival of Obligations*

- A. All representations, indemnifications, warranties, and guarantees made in, required by, or given in accordance with the Contract Documents, as well as all continuing obligations indicated in the Contract Documents, will survive final payment, completion, and acceptance of the Work or termination or completion of the Contract or termination of the services of Contractor.

17.05 *Controlling Law*

- A. This Contract is to be governed by the law of the state in which the Project is located.

17.06 *Headings*

- A. Article and paragraph headings are inserted for convenience only and do not constitute parts of these General Conditions.

SUPPLEMENTAL GENERAL CONDITIONS

GENERAL CONDITIONS

The General Conditions of the Contract for Construction, EJCDC Document C-700, 2007 Edition, as bound herewith, shall be the General conditions of the Contract, except as amended by these Supplemental General Conditions

CHANGES AND ADDITIONS TO VARIOUS ARTICLES OF THE GENERAL CONDITIONS

Article 1 Definitions

Article 1 is hereby modified as follows:

Delete the definition "Notice to Proceed"

Article 2 Preliminary Matters

Article 2.02 is modified as follows:

DELETE Article 2.02 in its entirety

Article 2.03 is modified as follows:

30th day is changed to 10th day, and delete "A Notice to Proceed...earlier"

Article 3 Reporting and Resolving Discrepancies

Article 3.03A.# - change "unless" to "that" and add knowledge thereof, or should have had knowledge of....

Article 4 Availability of lands

Article 4.01B – delete "as necessary for giving notice of or filing a mechanics or construction lien against such lands in accordance with applicable Laws & Regulations."

Article 4.06G – Hazardous Environmental Conditions at Site - Delete in its entirety

Article 5 Bonds and Insurance

Delete Article 5 in its entirety and substitute the following:

PERFORMANCE BOND AND LABOR AND MATERIAL PAYMENT BOND

The Contractor shall, within ten (10) days from the date of the Notice of Award, furnish the City of Meriden with a PERFORMANCE BOND and a LABOR AND MATERIAL PAYMENT BOND, both in the amount of 100% of the amount bid, conditioned upon the performance of the Contractor on all undertaking, covenants, terms, and conditions and agreements of the contract. The bond shall be in the form of the specimen bonds annexed hereto, such bonds shall be executed by the contractor and a corporate bonding company licensed, authorized, and admitted to transact such business in the State of Connecticut and named on the current list of "Surety Companies acceptable on Federal Bonds", as published in the "Treasury Department" listed for an amount equal to the amount of the reinsurance. Written evidence of how any excess suretyship has been placed by the surety signing the bonds shall accompany the bonds. The expense of the bonds shall be borne by the Contractor. If at anytime a surety on any such bond is declared bankrupt or loses its right to do business in the State of Connecticut, or is removed from the list of Surety Companies acceptable on Federal Bonds, or for any other justifiable cause, the Contractor shall, within ten (10) days after notice from the City of Meriden to do so. substitute an acceptable bond(s) in such form and sum and signed by such other surety or sureties as may be

paid by the Contractor. No payments shall be deemed due nor shall be made until the new surety or sureties have furnished an acceptable bond to the City.

If the Contractor is a partnership, the bonds shall be signed by each of the individuals who are partners; if a corporation, the bonds shall be signed in the correct corporation name by a duly authorized officer, agent, or attorney-in-fact. There should be executed an appropriate number of counterparts of the bond corresponding to the number of counterparts of the contract. Each executed bond shall be accompanied by 1) appropriate acknowledgements of the respective parties; 2) appropriate duly certified copy of Power of Attorney or other certificate of authority where bond is executed by agent, officer, or other representative of Contractor or surety; 3) a duly certified extract from by-laws or resolutions or surety under which Power of Attorney or other certificates of authority of its agent, officer, or representative was issued.

The Contractor hereby agrees and understands that a Notice of Award is expressly conditional upon the receipt of these bonds and a Certificate of Insurance naming the City of Meriden (and others as appropriate) as ADDITIONAL INSURED. If said documents are not received by the City of Meriden within ten (10) days from the date of Notice of Award, the City of Meriden reserves the right to withdraw its conditional acceptance of the bid and cancel the Notice of Award.

PERFORMANCE BOND

KNOW ALL MEN BY THESE PRESENTS, that

(here insert full name and address or legal title of Contractor)

as Principal hereinafter called contractor and

(here insert full name and address or legal title of Surety)

As Surety, hereinafter called Surety, are held and firmly bound unto

(here insert full name and address or legal title of Owner)

As Obligee, hereinafter called Owner, in the amount of

Dollars \$ _____

for the payment whereof Contractor and Surety bind themselves, their heirs, executors, administrators, successors and assigns, jointly and severally, firmly by these presents.

WHEREAS,

Contractor has by written agreement dated

20 , entered into a contract with Owner for

(here insert full name, address and description of project)

In accordance with Drawings and Specifications prepared by (here insert full name and address or legal title of Engineer/Architect)

Which contract is by reference made a part hereof, and is hereinafter referred to as the Contract.

PERFORMANCE BOND

NOW, THEREFORE, THE CONDITION OF THIS OBLIGATION is such that, if Contractor, shall promptly and faithfully perform said Contract, then this obligation shall be null and void; otherwise it shall remain in full force and effect.

The Surety hereby waives, notice of any alteration or extension of time made by the Owner.

Whenever Contractor shall be, and declared by Owner to be in default under the Contract, the Owner having performed Owner’s obligations thereunder, the surety may promptly remedy the default, or shall promptly

- 1) Complete the Contract in accordance with its terms and conditions, or
- 2) Obtain a bid or bids for completing the Contract in accordance with its terms and conditions, and upon determination by Surety of the lowest responsible bidder, or, if the Owner elects, upon determination by the Owner and the Surety jointly of the lowest responsible bidder, arrange for a contract between such bidder and Owner, and make available as Work progresses (even though there should be a default of a succession of

defaults, under the contract or contracts of completion arranged under this paragraph sufficient funds to pay the cost of completion less the balance of the contract price; but not exceeding, including other costs and damages for which the Surety may be liable hereunder, the amount set forth in the first paragraph hereof. The term “balance of the contract price,” as used in this paragraph, shall mean the total amount payable by Owner to Contractor under the Contract and any amendments thereto, less the amount properly paid by Owner to Contractor.

Any suit under this bond must be instituted before the expiration of two (2) years from the date on which final payment under the Contract falls due.

No right of action shall accrue on this bond to or for the use of any person or corporation other than the Owner named herein or the heirs, executors, administrators or successors of the Owner.

Signed and sealed this

day of

20

(Witness)

(Witness)

(Principal)

(Title)

(Surety)

(Title)

LABOR AND MATERIAL PAYMENT BOND

KNOW ALL MEN BY THESE PRESENTS, that

(here insert full name and address or legal title of Contractor)

as Principal, hereinafter called Principal, and

(here insert full name and address or legal title of Surety)

As Surety, hereinafter called Surety, are held and firmly bound unto

(here insert full name and address or legal title of Owner)

As Oblige, hereinafter called Owner, for the use and benefit of claimants as hereinbelow defined, in the amount of _____ **Dollars \$** _____

For the payment whereof Principal and Surety bind themselves, their heirs, executors, administrators, successors and assigns, jointly and severally, firmly by these presents.

WHEREAS,

Principal has by written agreement dated _____

(here insert full name, address and description of project)

20____, entered into a contract with Owner for

In accordance with Drawings and Specifications prepared by

(here insert full name and address or legal title of Engineer/Architect)

which contract is by reference made a part hereof, and is hereinafter referred to as the Contract.

LABOR AND MATERIAL PAYMENT BOND

NOW, THEREFORE, THE CONDITION OF THIS OBLIGATION is such that, if Principal shall promptly make payment to all claimants as hereinafter defined, for all labor and material used or reasonably required for use in the performance of the Contract, then this obligation shall be void; otherwise it shall remain in full force and effect, subject, however, to the following conditions:

1. A claimant is defined as one having a direct contract with the Principal or with a Subcontractor of the Principal for labor, material, or both, used or reasonably required for use in the performance of the Contract, labor and material being construed to include that part of water, gas, power, light, heat, oil, gasoline, telephone service or rental of equipment directly applicable to the Contract.

2. The above named Principal and Surety hereby jointly and severally agree with the Owner that every claimant as herein defined, who has not been paid in full before the expiration of a period of ninety (90) days after the date on which the last of such claimant's work or labor was done or performed or materials were furnished by such claimant, may sue on this bond for the use of such claimant, prosecute the suit to final judgment for such sum or sums as may be justly due claimant, and have execution thereon. The Owner shall not be liable for the payment of any costs or expenses of any such suit.

3. No suit or action shall be commenced hereunder by any claimant:

a) Unless claimant, other than one having a direct contact with the Principal, shall have given written notice to any two of the following: the Principal, the Owner, or the Surety above named, within ninety (90) days after such claimant did or performed the last of the work or labor, or furnished the last of the materials for which said claim is made, stating with substantial

accuracy the amount claimed and the name of the party to whom the materials were furnished, or for whom the work or labor was done or performed. Such notice shall be served by mailing the same by registered mail or certified mail, postage prepaid, in an envelop addressed to the Principal Owner or Surety, at any place where an office is regularly maintained for the transaction of business, or served in any manner in which legal process may be served in the state in which the aforesaid project is located, save that such service need not be made by a public officer.

b) After the expiration of one (1) year following the date on which Principal ceased Work on said Contract, it being understood, however, that if any limitation embodied in this bond is prohibited by any law controlling the construction hereof such limitation shall be deemed to be amended so as to be equal to the minimum period of limitation permitted by such law.

c) Other than in a state court of competent jurisdiction in and for the county or other political subdivision of the state in which the Project or any part thereof, is situated, or in the United States District Court for the district in which the Project, or any part thereof is situated, and not elsewhere.

4. The amount of this bond shall be reduced by and to the extent of any payment or payments made in good faith hereunder, inclusive of the payment by Surety of mechanics' liens which may be filed of record against said improvement, whether or not claim for the amount of such lien be presented under and against this bond.

Signed and sealed this

day of

20

(Principal)

(Title)

(Surety)

(Title)

(Witness)

(Witness)

INSURANCE REQUIREMENTS

*

All insurance coverage shall be provided by the Contractor and by or for any of their Subcontractors at no additional expense to the City. The scope and limits of insurance coverages specified are the minimum requirements and shall in no way limit or exclude the City from requesting additional limits and coverage provided under the Contractor's policies and/or their Subcontractors' policies. The Contractor shall either require each of their Subcontractors to produce identical insurance coverage requirements as detailed hereinafter or the Contractor shall secure the coverage for all Subcontractors under the Contractor's own policies.

The Contractor and/or Subcontractors shall be responsible for maintaining the stated insurance coverage in force for the life of the Contract with insurance carriers licensed and authorized to underwrite such insurance in the State of Connecticut. (Insurance carriers shall be rated A or higher by AM Best Co.)

The type and limits of insurance coverage shall not be less than the type and limits designated herein, and the Contractor and/or Subcontractors agree that the coverage or the acceptance by the City of Certificates of Insurance indicating the type and limits of insurance shall in no way limit the liability of the Contractor and/or subcontractor to any such type and limits of insurance coverage.

The insurance coverage hereinafter afforded by the Contractor and/or subcontractor shall be primary insurance, except when stated to apply in excess of or contingent upon the absence of other insurance. The amount and type of insurance shall not be reduced by the existence of other insurance's held by the City.

The Contractor and/or Subcontractor shall provide coverage's that are not impaired or the aggregate is not to be impaired by any other risk, past or present, and the limits required, shall be fully available to the City of Meriden or restored if depleted below the required levels during the course of the contract and/or any extensions thereto.

The Contractor and/or Subcontractor shall not commence work under the terms of this contract until they have obtained the liability insurance coverage required by this article and has filed Certificates of Insurance on same with the City, and the City has approved the Certificates of Insurance and the represented coverage.

Each Certificate of Insurance shall include the following pertinent information:

- Name of Insurance Carrier writing policy
- Name Insured
- Address of Named Insured
- Description of coverage (Workers' Compensation certificates should evidence the state(s) of operation including Connecticut)
- Policy Periods (effective and expiration dates)
- Limits of liability and terms
- Brief description of operations performed and property covered
- Name and address of certificate holder
- Authorized agent's name and address
- Date and signature of the issuing agent (original only)
- All additional named insured endorsement
- All cross liability endorsements
- All indemnification and hold harmless agreements (must be supported by Contractual Liability Insurance)

Each insurance policy (with the exception of OCP shall contain an endorsement naming the City as an Additional Insured, evidence of a Cross Liability endorsement so that each insureds interests are considered and treated separately in the case of claims between the insureds. The Contractor shall provide 60 Day advance Notification** to the City in the event of any material change, modification, cancellation, or non-renewal of insurance coverage.**

**Amended 01/13/14

The Contractor and/or Subcontractors shall include a waiver of subrogation rights, on all insurance policies, so that the City of Meriden cannot be sued by the Contractor's insurer to recover any payments made on behalf of the Contractor and/or Subcontractor.

All insurance policies provided by the Contractor and/or Subcontractors shall include an endorsement indicating that any breach of warranty, by the named insured, will not be imputed to another insured.

During the course of execution of the work, whenever there is a lapse in the insurance requirements as stated herein, through cancellation, expiration, failure to renew , or any other cause, the City shall order the cessation of all activities** until such time as the insurance requirements are complied with. The Contractor shall have no claim or claims whatever against the City, or other parties to the contract.

**Amended 01/13/14

The Contractor and their Subcontractors shall indemnify and save harmless the City of Meriden, and all additional named insured and all appointed or elected officers, officials, directors, committee members, employees, volunteer workers, commissioners, and any affiliated, associated, or allied entities and/or bodies of, or as may be participated in by the City of Meriden, or as may now or hereinafter be constituted or established from and against all claims, damages, and losses and expenses including attorney's fees arising out of or resulting from the performance of the work under this contract, provided that any such claims, damage, loss or expense is attributable to bodily injury, sickness, disease or death, or to injury to, or destruction of tangible property, including the loss of use resulting therefrom; and is caused in whole or in part by any negligent or willful act or omission of the Contractor, and their Subcontractors, anyone directly or indirectly employed by any of them or anyone for whose acts any of them may be liable.

The Contractor and their Subcontractors shall, during the execution of the work, take necessary precautions and place proper guards for the prevention of accidents; shall set up all night suitable and sufficient lights and barricades; shall fully comply with the latest revisions of the Occupational Safety and Health Act of 1970 and all other Federal, State and Local Regulations, including any all amendments, revisions, and additions thereto, and shall indemnify and save harmless the City of Meriden and their additional named insured and their employees, officers, agents from any and all claims, suits, actions, fines, fees, damages, and costs to which they may incur by reason of death or injury to all persons and/or for all property damage of another resulting from non-compliance, unskillfulness, willfulness, negligence, or carelessness in the execution of the work, or in guarding or protecting the same, or from any improper methods, materials, implements or appliances used in execution of the work, or by or on account of any direct or indirect act or omission of the Contractor of their Subcontractors or their employees or agents.

The Contractor shall be responsible for initiating, maintaining, and supervising all safety precautions and programs in connection with the execution of the contract.

The Contractor shall take all reasonable precautions for the safety of, and shall provide all reasonable protection to prevent damage, injury, or loss to; 1) all employees on the work and all other persons who may be affected thereby; 2) all the work and all the materials and equipment to be incorporated therein, whether in storage in or on the site, under the care, custody, or control of the Contractor or any of their Subcontractors; and 3) other property at the site or adjacent thereto, including trees, shrubs, lawns, walks, pavements, roadways, structures, and utilities not designed for removal, relocation, or replacement in the course of construction.

The Contractor shall erect and maintain, as required by existing conditions and progress of the work, all reasonable safeguards for safety and protection, including posting danger signs and other warnings against hazards promulgating safety regulations and notifying owners and users of adjacent utilities.

The Contractor and/or subcontractor shall give all notices and comply with all applicable laws, ordinances, rules, regulations, and lawful orders for any public authority bearing on the safety of persons or property or their protection from damage, injury, or loss.

When The use or storage of explosives or other hazardous materials or equipment is necessary for the execution of work, the Contractor and/or their Subcontractors shall exercise the utmost care and shall carry on such activities under the supervision of properly qualified personnel.

The contractor shall designate a responsible member of their organization at the site whose duty shall be the prevention of accidents. This person shall be the Contractor's superintendent unless otherwise designated by the Contractor in writing to the City.

In any emergency affecting the safety of persons or property, the Contractor shall act to prevent threatened damage, injury, or loss.

The Contractor, Subcontractor, and their insurer(s) shall waive governmental immunity as a defense and shall not use the defense of governmental immunity in the adjustment of claims or in the defense of any suit, action or claim brought against the City. Nothing shall limit the City of Meriden from utilizing the defense of governmental immunity.

Contractor shall agree to maintain in force at all times during the contract the following minimum coverages and shall name the City Meriden as an Additional Insured on a primary and non-contributory basis to all policies except Workers Compensation. All policies should also include a Waiver of Subrogation. Umbrella/Excess shall state that it follows form over General Liability, Auto Liability and Workers Compensation. Insurance shall be written with Carriers approved in the State of Connecticut and with a minimum AM Best's Rating of "A-" VIII. In addition, all Carriers are subject to approval by the City of Meriden.

		(Minimum Limits)
General Liability	Each Occurrence	\$1,000,000
	General Aggregate	\$2,000,000
	Products/Completed Operations Aggregate	\$2,000,000
Auto Liability	Combined Single Limit	
	Each Accident	\$1,000,000
Umbrella (Excess Liability)	Each Occurrence	\$1,000,000
	Aggregate	\$1,000,000
Workers' Compensation and Employers' Liability	WC Statutory Limits	
	EL Each Accident	\$1,000,000
	EL Disease Each Employee	\$1,000,000
	EL Disease Policy Limit	\$1,000,000

Original, completed Certificates of Insurance must be presented to the City of Meriden prior to contract issuance. Contractor agrees to provide replacement/renewal certificates at least 60 days prior to the expiration date of the policies.

Article 6 Substitutes and "or equals"

Article 6.05.2.A – After Contractor add "or Owner"

Article 6.05.2.2E – Substitute Items - Add the words "If, in the owner's opinion, the number of substitutions is excessive" after "reimburse Owner for the reasonable charges of Engineer for evaluating each such proposed substitutes".

Add the following paragraph 6.09D:

The requirements of subparagraph 6.09 do not waive the Contractor's responsibility of complying with the requirement of the Contract Documents when such regulations and requirements exceed those of any laws, ordinances, rules, regulations and orders of any public authority bearing the work.

Delete Article 6.10 in its entirety and substitute the following:

Under the terms of Regulation 16, referring to Contractors and Subcontractors issued by the State Tax Commission in administration of the State Sales and Use Tax, the Contractor may purchase materials or supplies to be consumed in the performance of this Contract without payment of Tax and shall not include in his Bid nor charge any Sales or Use Tax on any materials or labor provided.

Amend Article 6.12 to read:

“Contractor shall maintain in a safe place at the Site two (2) record copies...”

Add the following to article 6.13:

6.13.A.4 Protection in general shall consist of the following:

6.13.A.5 The Contractor shall furnish approved hard hats, other personal, protective equipment as required, approved first aid supplies, name of first aid attendant, and a posted list of emergency facilities.

6.13.A.6 The Contractor shall take prompt action to correct any hazardous conditions reported.

6.13.A.7 The Contractor shall be responsible for the adequate strength and safety of all scaffolding, staging and hoisting equipment, and for temporary shoring, bracing and tying.

The Contractor shall comply with the requirements of the Occupational Safety and Health Act of 1970 and the Construction Safety Act of 1969, including all Standards and Regulations which have been promulgated by the Governmental Authorities which administer such acts; and said Requirements, Standards and Regulations are incorporated herein by reference.

The Contractor shall be directly responsible for compliance therewith on the part of its agents employees, material men and Subcontractors, and shall directly receive and be responsible for all citations, assessments, fines or penalties which may be incurred by reason of its agents, employees, material men or Subcontractors, to so comply.

The Contractor shall indemnify the Owner and the Engineer and save them harmless from any and all losses, costs and expenses, including fines and reasonable attorney’s fees incurred by the Owner and the Engineer by reason of the real or alleged violation of such laws, ordinances, regulations and directives, Federal, State and local, which are currently in effect or which become effective in the future, by the Contractor, his Subcontractors or material men.

6.16 Emergencies

Add 6.16.B – The Contractor shall provide the Owner with at least two (2) phone numbers in case of emergency.

Article 8 – Replacement of Engineer

Delete 8.02 in its entirety

8.06 – Insurance

8.06A – Delete Article 5, Add Supplemental General Conditions

Article 9 - Engineer's Status During Construction

Revise 9.03.B to read:

In addition to the Engineer, The Owner may employ a Clerk-of- the Works shall be authorized to observe all material, workmanship and equipment for compliance with the Contract Documents' requirements of tests and safety provisions, and report any variance to the Engineer. He shall have no authority to interpret, vary or suspend the requirements of the Contract.

The Clerk-of-the-Works will keep records of material deliveries, weather conditions and manpower; he will monitor compliance with the approved Construction Schedule and the Equal Employment Provisions.

The Contractor shall cooperate with the Clerk-of-the-Works in the performance of his duties, and shall provide access to all portions of the work and information required for his records. Any requests for modification of the Contract provisions or working procedures shall be reviewed with the project representative prior to making submittal(s) to the Engineer.

Cost of Work, Allowances; Unit Price Work

Article 11 is hereby modified as follows:

Add the following Articles:

11.03D Delete the entire paragraph and substitute the following:

It is understood and agreed that the prices bid for the various units of construction shall control in any Contract awarded hereafter. The City of Meriden reserves the right to revise the estimated quantities with no fixed limits set nor extra compensation allowed other than the above stated unit prices.

Article 12 – Change of Contract Price and Change of Contract Time

Add the following:

12.01.B.4 - The Contractor, when performing work under article 11.3.3 shall, upon request, promptly furnish in a form satisfactory to the Owner, itemized statements of the cost of the work so ordered, including, but not limited to, certified payrolls, and copies of accounts, bills and vouchers to substantiate the above estimates.

Add 12.04.1 -The Contractor guarantees that he can and will complete the work within the time specified or within the time as extended as provided elsewhere in the Contract Documents. Inasmuch as the damage and loss to the City of Meriden which will result from the failure of the Contractor to complete the work within the stipulated time will be most difficult or impossible of accurate assessment, the damages to the City for such delay and failure on the part of the Contractor shall be liquidated in the sum of \$250.00 each calendar day (Sundays and Holidays included) by which the Contractor shall fail to complete the work or any part thereof in accordance with the provisions hereof and such liquidated damages shall not be considered as a penalty. The City will deduct and retain out of any money due to become due hereunder, the amount of liquidated damages, and in case those amounts are less than the amount of liquidated damages, the Contractor shall be liable to pay the difference upon demand by the City.

Article 13 - Warranty and Guarantee; Tests and Inspections; Correction, Removal or Acceptance of Defective Work

Article 13.02 is modified to include the following:

The Contractor shall make every effort to minimize damage to all access routes, and he shall acquire all necessary permits for working in, on or from public streets or rights of way and for securing access rights of their own.

All costs of the removal and restoration to original condition of walls, fences and structures, utility lines, poles, guy wires or anchors, and other improvements required for passage of the Contractor's equipment shall be borne by the Contractor. The Contractor shall notify the proper authorities of the City and all utilities of any intended modifications or disruption to their property prior to the start of construction, and shall cooperate with them in the scheduling and performance of this operation.

Article 14 Payments to Contractor and Completion

Modify 14.02.D.4 to read:

Payments may be withheld to Contractors who are in default through debt or contract to the City.

14.07C – Change “thirty days” to “forty five (45) days”

Delete 14.09A in its entirety.

Article 15 Suspension of work and termination

Delete 15.03.3 in its entirety.

15.04B – Change 30 to 45 and change “30 days to pay” to 60.

WASHINGTON MIDDLE SCHOOL
BOILER REPLACEMENT
1225 N BROAD STREET, MERIDEN CT 06450

SECTION 00010

TABLE OF CONTENTS

GENERAL

00000	COVER
00010	TABLE OF CONTENTS
00020	LIST OF DRAWINGS

DIVISION 0 – BIDDING REQUIREMENTS AND CONTRACT FORMS

	LEGAL NOTICE (INVITATION TO BID)
	INFORMATION TO BIDDERS
	NON-COLLUSIVE BID STATEMENT
	REQUEST FOR STATUS AS A MERIDEN BASED BUSINESS.
	BIDDERS QUALIFICATIONS
	FORM OF SURETY/BID BOND
	PROPOSAL PAGES
	STANDARD FORM OF AGREEMENT
	GENERAL CONDITIONS
	SUPPLEMENTAL CONDITIONS - INCLUDES INSURANCE REQUIREMENTS AND PERFORMANCE BOND & LABOR MATERIAL BOND

DIVISION 22/23 – PLUMBING/ MECHANICAL

20 00 50	GENERAL CONDITIONS FOR MECHANICAL AND ELECTRICAL SYSTEMS
22 05 00	COMMON WORK RESULTS FOR PLUMBING
22 07 00	PLUMBING INSULATION
23 05 48	VIBRATION ISOLATION AND SEISMIC RESTRAINTS
23 05 93	TESTING, ADJUSTING AND BALANCING.
23 07 00	MECHANICAL INSULATION
23 0923	TEMPERATURE CONTROLS
23 50 00	HEATING EQUIPMENT
23 51 33	BREACHING CHIMNEY AND STACKS FOR CONDENSING APPLIANCES

DIVISION 26 – ELECTRICAL

26 00 00	GENERAL ELECTRICAL
26 05 00	BASIC ELECTRICAL MATERIALS & METHODS
26 29 23	VFD -ACH580

SECTION 00020

LIST OF DRAWINGS

COVER

M1.1	BOILER ROOM - MECHANICAL DEMOLITION PART PLAN
M1.2	BOILER ROOM - MECHANICAL NEW WORK PART PLAN
M1.3	MECHANICAL DETAILS
M1.4	SCHEMATIC PIPING DIAGRAM, TEMPERATURE CONTROL DIAGRAM and MECHANICAL DETAILS
M1.1	BOILER ROOM - ELECTRICAL DEMOLITION and NEW WORK PART PLANS

**WASHINGTON MIDDLE SCHOOL
BOILER REPLACEMENT
1225 N BROAD STREET, MERIDEN CT 06450**

END OF LIST OF DRAWINGS

**WASHINGTON MIDDLE SCHOOL
BOILER REPLACEMENT
1225 N BROAD STREET, MERIDEN CT 06450**

SECTION 20 00 50 - GENERAL CONDITIONS FOR MECHANICAL AND ELECTRICAL SYSTEMS

PART 1 - GENERAL

1.1 RELATED DOCUMENTS:

- A. The General provisions of the Contract, including General and Supplementary Conditions, and Division 1, General Requirements apply to the work specified in this Section.
- B. Scope of Work: This Section contains special provisions for Divisions 22,23 and 26.

1.2 EXAMINATION OF SITE AND DRAWINGS:

- A. Before submitting his bid, Contractor shall visit site with plans and specifications in hand, shall consult with the Engineer and shall become thoroughly familiar with all conditions under which his work will be done since he will be held responsible for any assumptions, he may make in regard thereto.
- B. The Contractor shall verify and obtain all necessary dimensions at the building.
- C. Certain present building clearances are available for handling equipment.

1.3 INTENT:

- A. Finished Work: The intent of the specifications and drawings is to call for finished work, completed, tested and ready for operation.
- B. Good Practice: It is not intended that the drawings show every pipe, fitting or minor detail and it is understood that while the drawings must be followed as closely as circumstances will permit, the systems shall be installed according to the intent and meaning of the Contract Documents and in accordance with good practice.
- C. Work under each Section shall include giving written notice to the City of Meriden within 15 days after the Award of the Contract of any materials of apparatus believed inadequate or unsuitable or in violation of any laws or codes, or items of work omitted. In the absence of such written notice, it is mutually agreed that work under each Section has included the cost of all required items and labor for the satisfactory functioning of the entire system without extra compensation.
- D. Any apparatus, appliance, material or work not shown on drawings but mentioned in specifications or vice versa, or any incidental accessories necessary to make the work complete and perfect in all respects and ready for operation, even if not particularly specified, shall be furnished and installed by Contractor at no additional cost to the City of Meriden.
- E. Prior to receipt of bids, Contractors shall give written notice to Engineer of any materials or apparatus believed inadequate, unsuitable or in violation of laws, ordinances, rules or regulations of authorities having jurisdiction and any necessary items or work omitted. In the absence of such written notice, it is mutually agreed that Contractor has included the cost

**WASHINGTON MIDDLE SCHOOL
BOILER REPLACEMENT
1225 N BROAD STREET, MERIDEN CT 06450**

of all required items in his proposal and that he will be responsible for approved satisfactory functioning of systems without further compensation.

- F. In all cases where apparatus is herein referred to in singular number, it is intended that such reference include as many such items as are required to complete work.
- G. If not otherwise specified or shown on plans, apparatus and materials shall be installed in accordance with manufacturer's published recommendations and instructions and to the complete satisfaction of the Engineer.
- H. It is the intent of these specifications for Mechanical and Electrical Contractors and/or their subcontractors or equipment suppliers to furnish all equipment complete with all accessories.

1.4 REGULATIONS:

- A. Codes: All work shall be done in strict accordance with the 2024 Connecticut State Building Code, 2022 Connecticut State Fire Safety Code, 2021 IBC, 2021 IPC, 2021 IMC, Connecticut Public Health Code, 2021 NFPA 101, all applicable NFPA Codes, NEC, UL, NEMA, O.S.H.A., with all requirements of local utility companies and the requirements of all governmental departments having jurisdiction.
- B. Precedence: Requirements of the above shall take precedence over plans and specifications.
- C. Equipment construction standards shall be as follows: Pressure vessels shall be constructed in accordance with the ASME Code, all electrical equipment shall be UL listed and approved and conform to the N.E.C., gas equipment shall be approved by A.G.A. and conform to N.F.P.A. Codes, piping materials, fittings, valves and accessories shall be constructed in accordance with A.S.T.M. and A.N.S.I. standards for class of work involved. All equipment and materials shall be new and of domestic manufacture. All the above codes shall be referenced and dated in the Connecticut Basic Building Code.
- D. Wherever discrepancies occur between above regulations and agencies and contract drawings and specifications, the requirements of above shall take precedence, except that the contract drawings and specifications shall be minimum requirements and

1.5 APPROVED FITTINGS
~~and contractors shall advise engineer of any required changes before proceeding with work.~~

- A. No material other than that contained in the "Latest List of Electric Fittings" approved by the Underwriters' Laboratories, Inc., shall be used in any part of the work. All wiring, conduit, switches and other material for which label service has been established, shall bear the label of the Underwriters' Laboratories, Inc.

**WASHINGTON MIDDLE SCHOOL
BOILER REPLACEMENT
1225 N BROAD STREET, MERIDEN CT 06450**

1.6 PERMITS, FEES:

- A. Include all necessary notices, obtain all permits and pay all governmental taxes, fees, and other costs. File all necessary plans, prepare all documents and obtain all necessary approvals of all governmental departments having jurisdiction. Obtain all required Certificates of the City of Meriden before request for acceptance and final payment for the work.

1.7 DEFINITIONS:

- A. Words "finish" or "finished" refer to all rooms and areas listed in Finished Schedule on Drawings. All rooms and areas not covered in Schedule, including underground tunnels and areas above ceilings, shall be considered not finished except as otherwise noted.
- B. The word "provide" means to "furnish and install" reference item.

1.8 PROTECTION:

- A. Work under each section shall include protecting the work and materials of all other sections from damage by work or workmen, and shall include making good any and all damage thus caused.
- B. Each section shall be responsible for work and equipment until finally inspected, tested and accepted. Protect work against theft, weather, injury or damage and carefully store material and equipment received on site which is not immediately installed. Close open ends of work with temporary covers or plugs during construction to prevent entry of obstructing materials.
- C. If so specified under the respective section, work may include receiving, unloading, uncrating, storing, protecting, setting in place and connecting up completely of any motor starters, control equipment having mechanical/electrical service connections which may be furnished by The City of Meriden or furnished under another section. Work under each section shall include exercising special care in handling and protecting equipment and fixtures. Any of the above equipment and fixtures which are missing or damaged by reason of mishandling or failure to protect shall be replaced at no additional cost to the City of Meriden.

1.9 EQUIPMENT SUBSTITUTIONS AND DEVIATIONS:

- A. Wherever more than one manufacturer is mentioned in specifications and drawings, any of these named are considered equally acceptable to that on upon which design was based and, providing all requirements are met, insofar as performance, space requirements, noise levels and special accessories or materials are concerned, any of those named may be included in Contractor's bid.
- B. Where Contractor proposes to use an item of equipment which differs from that upon which design was based, which required any redesign of structure, partitions, foundations, piping, wiring or of any other part of Mechanical or Electrical Layout, all such redesign, new drawings or detailing required shall be prepared by Contractor at his own expense for approval of Engineer.

**WASHINGTON MIDDLE SCHOOL
BOILER REPLACEMENT
1225 N BROAD STREET, MERIDEN CT 06450**

- C. Where approved substitutions or deviations require a different quantity, size or arrange of structural supports, wiring, conduit, piping, ductwork, and equipment from that upon which design was based, all additional items required by the systems shall, with the approval of Engineer, be furnished by Contractor at no additional cost to The City of Meriden.

1.10 ELECTRICAL WORK:

- A. The Electrical Section includes all power wiring for all electrical switches, motor starters and unmounted motors, furnished at the job site by other sections or furnished under the Electrical Sections as stated in other sections of the specifications.
- B. The Electrical Section shall install and wire all starters, switches and controls, as specified and/or shown on drawings. This shall include all operating and safety controls. Refer to sections 260000 and 260500 for additional information.
- C. Electrically operated equipment supplied by other sections which will be installed and wired by Electrical Section shall be delivered to him with detailed instructions for their installation and wiring in sufficient time and proper sequence to enable him to meet his work schedule.
- D. Control devices that include mechanical elements, such as float switches, shall be installed by the section furnishing them, but be wired by the Electrical Sections.
- E. Equipment which includes a number of correlated electrical control devices mounted in a single enclosure or on a common base with equipment shall be supplied for installation completely wired as unit with terminal boxes and ample leads and/or terminal strips, ready for electrical wiring.
- F. Electrical Contractor shall furnish local disconnect switch for all equipment and manual motor starter for fractional HP motors.

1.11 DRAWINGS:

- A. The mechanical and electrical drawings are intended to supplement each other and are to be considered as a unit which, taken together in conjunction with the specifications, completely describes the work to be done. All drawings shall be checked to verify spaces in which work will be installed. Where headroom or space conditions appear inadequate, notification shall be given to Engineer before proceeding with installation.
- B. The Engineer may without charge, make modifications in the layout as needed to prevent conflict with work of other trades or for proper execution of the work.
- C. Note that the drawings are diagrammatic and indicate the general arrangement of the Mechanical and Electrical Equipment and systems, without showing every detail and fitting.
- D. Where conflicts occur between drawings and specifications or within either, the item or arrangement of better quality, greater quality or highest cost shall be included in Contract price. Engineer shall determine the manner or item with which work shall be installed.
- E. Keep one complete set of all drawings, specifications, shop drawings and addenda on the premises at all times in good condition and available to the Engineer and The City of Meriden.

**WASHINGTON MIDDLE SCHOOL
BOILER REPLACEMENT
1225 N BROAD STREET, MERIDEN CT 06450**

1.12 REVIEWS:

- A. The materials, workmanship, design and arrangement of all work installed under the Mechanical and Electrical sections shall be subject to the review of the Engineer.
- B. Where any specific material process or method of construction or manufactured article is specified by name or by reference to the catalog number of a manufacturer, the specifications are to be used as a guide and not intended to take precedence over the basic duty and performance specified or noted on drawings. In all cases, the specific characteristics of the equipment offered for approval, shall be indicated on the shop drawings.
- C. All component parts of each item of equipment or device shall bear the manufacturer's nameplate, giving name of manufacturer, description, size, type, serial or model number, electrical characteristics, etc. in order to facilitate maintenance or replacement. The nameplate of a subcontractor or distributor will not be acceptable.
- D. If material or equipment is installed before it is reviewed, it shall be removed and replaced at no extra charge to the City of Meriden if, in the opinion of the Engineer, the material or equipment does not meet the intent of the drawings and specifications.

1.13 SHOP DRAWINGS:

- A. Contractor shall submit for review electronic copies of shop drawings of all new equipment, materials, piping, lighting fixtures, devices, panels and wiring. Engineer's review of shop drawings must be completed before any equipment is purchased or any work is installed.
- B. Shop drawings shall consist of manufacturer's certified scale drawings, cuts or catalog, including descriptive literature and complete certified characteristics of equipment, showing dimensions, capacity, code requirements, motor and drive testing as indicated on the drawings or specifications. Also, sheet metal fabrication drawings drawn to scale of 1/4" to the foot or larger.
- C. Certified performance curves for all pumping equipment shall be submitted for review.
- D. Samples, drawings, specifications, catalogs, etc. submitted for review shall be properly labeled indicating specific service for which material or equipment is to be used, division and article number of specifications governing Contractor's name and name of job.
- E. Catalog, pamphlets or other documents submitted to describe items on which review is being requested, shall be specific and identification in catalog, pamphlet, etc. of item submitted shall be clearly made in ink. Data of a general nature will not be accepted.
- F. Review stamp rendered on shop drawings shall not be considered as a guarantee of measurements of building conditions.

Where drawings are reviewed, said review does not mean that drawings have been checked in detail. Said review does not in any way relieve the Contractor from his responsibility or necessity of furnishing material or performing work as required by the Contract Drawings and Specifications.

**WASHINGTON MIDDLE SCHOOL
BOILER REPLACEMENT
1225 N BROAD STREET, MERIDEN CT 06450**

- G. Failure by the Contractor to submit shop drawings in ample time for checking shall not entitle him to an extension of Contract and no claim for extension by reason of such default will be allowed.
- H. Prior to submission to shop drawings, the Contractor shall thoroughly check each shop drawing, reject those not conforming to the specifications and indicate by his signature that the shop drawings submitted in his opinion meet Contract requirements.

1.14 CUTTING AND PATCHING:

- A. All cutting of openings in walls, floors, partitions, etc. must be done by the Electrical and/or Mechanical Contractor as required to install the work including all cutting of existing construction work. Cutting shall be neatly done and limited to the minimum size necessary. Contractor shall patch and restore to its original condition any work disturbed as a result of work under this Contract.

PART 2 - PRODUCTS

2.1 MATERIALS AND WORKMANSHIP:

- A. All materials and apparatus used shall be new, of first class quality and shall be furnished, delivered, erected, connected and finished in every detail. No materials or apparatus used shall be discontinued or about to be discontinued items.
- B. The Engineer shall have the right to reject any part of the work in case material or workmanship is not of satisfactory quality.
- C. Any unacceptable work and material shall be replaced with acceptable work and material at no additional expense to the City of Meriden.
- D. In case there is any doubt of the acceptability of any material, submit samples to the Engineer for approval and only definite approval in writing from the Engineer shall be evidence of such approval.
- E. Such approval shall also be subject to the satisfactory installation of the material.
- F. The work in each of these sections shall be constantly under the direction of a competent superintendent who shall be on the premises during such period as the work is in progress. The superintendent shall familiarize himself with the work of all other sections involved insofar as they relate to or in any way affect the work of these sections, and shall coordinate the work.
- G. Unless otherwise noted, all equipment and materials shall be installed and/or applied in accordance with the recommendations of the manufacturer of said equipment, including the performance of any tests recommended by the manufacturer.

2.2 EQUIPMENT VARIATIONS:

- A. In these specifications and on the accompanying drawings, one or more makes of materials, apparatus or appliances have been specified for use in this installation.

**WASHINGTON MIDDLE SCHOOL
BOILER REPLACEMENT
1225 N BROAD STREET, MERIDEN CT 06450**

This has been done for convenience in fixing the standard of workmanship performance of any materials, apparatus or appliance which shall be substituted for those mentioned herein shall also conform to these standards.

- B. Where no specified make or material, apparatus or appliance is mentioned, any first class product made by a reputable manufacturer may be used, providing it conforms to the requirements of these specifications and meets the approval of the Engineer prior to installation.
- C. To substitute other makes of materials, apparatus or appliance, than those mentioned under the mechanical or electrical sections, a request in writing to be allowed to make the substitution shall be made. This request shall be accompanied by complete plans and specifications of the substitution offered. If so requested by the Engineer, also submit samples of both the specified material or appliance and the substitute.

2.3 MOTOR CONTROL:

- A. All motors will be fed from a motor starter. Motor starters shall be furnished by each respective trade for motor driven equipment provided by them. The Electrical Contractor shall install the starters and shall provide all power wiring to the starters, and from the starters to the motors they control. Where required, remote pushbuttons, plates and pilots will be furnished with the starter and will be installed by the Electrical Contractor, unless otherwise called for under the Temperature Control Section of these specifications. All starters for motors which are to be interlocked with another motor shall have suitable auxiliary contacts.
- B. All small motors without built-in thermal protection shall be furnished with thermal switches. These switches and pilots shall be furnished by the Electrical Contractor.

2.4 ELECTRIC MOTORS:

- A. All motors 1/2 h.p. and above shall be integral horsepower polyphase induction motors conforming to NEMA standards MG-1-1967 and shall be T-frame design in sizes 143 T through 445 T. Each shall be NEMA design B with minimum torque values per MG 1-12.37 and 12.38.
- B. Duty shall be continuous, ambient temperature 40 degrees maximum, allowable temperature rise for open drip-proof -90 degrees, TEFC, 80 degrees C with Class B insulation rating all per MG 1-12.42.
- C. Horsepower, speed and frame sized per MG 1-10, 32, 13.02 and 13.06a.
- D. Enclosures - open drip-proof and TEFC per MG 1-1.25, 1.26 and 1.27.
- E. All dimensions per MG 1-11.31a, 11.32a and 11.34a. All motors shall have stainless steel nameplates with NEMA voltage standards shown.
- F. Locked rotor KVA per horsepower shall be designated by proper NEMA code letter per MG 1.10.37.

**WASHINGTON MIDDLE SCHOOL
BOILER REPLACEMENT
1225 N BROAD STREET, MERIDEN CT 06450**

- G. All motors shall be premium efficiency type with a full load efficiency range of 80 percent to 95 percent. High efficiency motor rating shall meet Northeast Utilities Energy Action Program in accordance with the following schedule:

MINIMUM NOMINAL MOTOR EFFICIENCIES

HP	OPEN DRIP PROOF			HP	TOTALLY ENCLOSED		
	MINIMUM EFFICIENCY				MINIMUM EFFICIENCY		
	1200	1800	3600		1200	1800	3600
1	82.5%	85.5%	80.0%	1	82.5%	85.5%	78.5%
1.5	86.5%	86.5%	85.5%	1.5	87.5%	86.5%	85.5%
2	87.5%	86.5%	86.5%	2	88.5%	86.5%	86.5%
3	89.5%	89.5%	86.5%	3	89.5%	89.5%	88.5%
5	89.5%	89.5%	89.5%	5	89.5%	89.5%	89.5%
7.5	91.7%	91.0%	89.5%	7.5	91.7%	91.7%	91.0%
10	91.7%	91.7%	90.2%	10	91.7%	91.7%	91.7%
15	92.4%	93.0%	91.0%	15	92.4%	92.4%	91.7%
20	92.4%	93.0%	92.4%	20	92.4%	93.0%	92.4%
25	93.0%	93.6%	93.0%	25	93.0%	93.6%	93.0%
30	93.6%	94.1%	93.0%	30	93.6%	93.6%	93.0%
40	94.1%	94.1%	93.6%	40	94.1%	94.1%	93.6%
50	94.1%	94.5%	93.6%	50	94.1%	94.5%	94.1%
60	95.0%	95.0%	94.1%	60	94.5%	95.0%	94.1%
75	95.0%	95.0%	94.5%	75	95.0%	95.4%	94.5%
100	95.0%	95.4%	94.5%	100	95.4%	95.4%	95.0%

- H. Service Factors - open-drip-proof, 1 h.p. through 200-1.15 TEFC all horsepower - 1.0.
- I. Noise level within NEMA standard MG 1-12.49.
- J. In addition to the above, all motors 1 through 20 h.p. shall be TEFC with drain holes for both horizontal and vertical positions. Each shall be equipped with deep groove double shielded ball bearings prelubricated with provisions for regreasing.
- K. Motors smaller than 1/2 h.p. shall be capacitor-start or split-phase type designed for 120 volts, single phase, 60 cycles alternating current.

2.5 ELECTRICAL MOTOR STARTERS:

- A. Motor starters shall be furnished by each respective trade for motor driven equipment provided by them. The Electrical Contractor shall install the starters and shall provide all power wiring to the starters, and from the starters to the motors they control.
- B. Motor starters shall conform to requirements of NEC, NEMA, UL, CSA, and ANSI and shall be suitable for the required horsepower, duty, voltage, phase, frequency, service, and location. All starters shall be furnished in NEMA enclosures suitable for the environment in which they are to be located.

**WASHINGTON MIDDLE SCHOOL
BOILER REPLACEMENT
1225 N BROAD STREET, MERIDEN CT 06450**

- C. All starters shall be of the same manufacture and shall be furnished in Cutler-Hammer, Square D, General Electric, or Allen Bradley.
- D. Thermal Overloads:
 - 1. All motors 1/8 horsepower or larger shall be provided with thermal-overload protection. Thermal overloads shall be melting alloy ambient temperature compensating type.
 - 2. Thermal overloads shall be sized in accordance with NEC requirements for the nameplate data of the motor(s) as actually delivered to the site.
- E. Starters for manual control of single phase motors up to one (1) horsepower furnished without integral thermal overloads shall be combination manual disconnect switch and starters with thermal overload protection for each ungrounded leg. Starters shall be inoperable if a thermal unit is removed. These starters shall be 2-pole and shall be provided with green neon pilot light and handle guard/lock-off.
- F. Starters for three phase motors shall be full voltage, circuit breaker combination magnetic starters. All circuit breaker combination magnetic starters shall include melting alloy type thermal overload protection, low voltage protection, and two (2) sets of auxiliary normally open and normally closed contacts. Thermal overload protection shall be provided in each ungrounded leg. Starters shall be inoperable if a thermal unit is removed.

All circuit breaker combination magnetic starters shall be equipped with control power circuits. Provide starters with control power transformers of secondary voltage required for the control power circuitry. Provide control power transformers with secondary fusing.

The disconnect handle on circuit breaker combination magnetic starters shall always be in control of the disconnect device with the door opened or closed. The disconnect handle shall be clearly marked as to whether the disconnect device is "on" or "off", and shall include a two-color handle grip, the black side visible in the "off" position, and the red side visible in the "on" position.

 - 1. All circuit breaker combination magnetic starters for manual control of three phase motors shall have start-stop push buttons in the cover and shall be provided with red and green pilot lights.
 - 2. All circuit breaker combination magnetic starters for automatic or interlocking control of three phase motors shall have hand-off-automatic selector switches in the cover and shall be provided with red and green pilot lights.
- G. Starters shall be furnished as part of respective equipment furnished under each Division.

PART 3 - EXECUTION

3.1 CONNECTING TO EXISTING UTILITIES:

- A. Connections to existing utilities that will interrupt the service to the present buildings shall be made at a time agreed upon by the City of Meriden,

**WASHINGTON MIDDLE SCHOOL
BOILER REPLACEMENT
1225 N BROAD STREET, MERIDEN CT 06450**

- B. If it is necessary to make connections to existing utilities outside the regular working hours, this shall be noted on the written work order and the respective Contractor will be paid for the additional cost of labor over and above what it would cost at regular day time rates.

3.2 FREIGHT, CARTING AND RIGGING:

- A. Contractor shall pay all freight and carting charges necessary to deliver all equipment furnished under his Contract to the site and furnish all necessary rigging to properly rig and set the apparatus on the foundations, frames, etc.
- B. All scaffolding, blocks and tackle, ropes and chains and other equipment necessary to rig and set the apparatus shall be furnished by the Contractor.
- C. The Contractor shall set, level and align all equipment before starting operations.

3.3 SEISMIC RESTRAINTS:

- A. It is the intent of this seismic restraint portion of the specification to provide restraint of all non-structural building system components provided in Sections 15 and 16 in Seismic Zone II. Restraint systems and devices are intended to withstand, without failure, the "G" forces detailed in the chart below:

Design Level of Acceleration At Equipment Center of Gravity Seismic Zone 2)
($A_v > 0.1$ to 0.19)

Elevation (feet rel. to grade level)	Rigid* Mnt'd Equip	Non-Struct. Architect Component	Flexible* Mnt'd Equip	Pipe, Duct, Cable trays, Conduit, Etc.	Life Safe. Equip
Below Grade up to 20 feet above grade	0.125 "g"	0.250 "g"	0.500 "g"	0.350 "g"	1.000 "g"
21 ft. - 300 ft.	0.500 "g"	0.550 "g"	0.750 "g"	0.650 "g"	1.000 "g"
301 ft. - 600 ft.	0.750 "g"	0.900 "g"	1.000 "g"	1.000 "g"	1.000 "g"

* Rigid mounted equipment is any equipment mounted directly to structure. Flexible mounted equipment is any equipment mounted on resilient supports, ceiling suspended, roof supported or mounted on an independent frame with any primary natural frequency below 16 Hz.

- B. Seismic restraints shall be as required by 2003 IBC, Chapter 16 and State of Connecticut 2005 Supplement.
- C. Seismic Certificate and Analysis
 - 1. Seismic restraint calculations must be provided for all connections of equipment to the structure.
 - 2. Calculations to support seismic restraint designs must be stamped by a registered professional engineer licensed in the State of Connecticut.

**WASHINGTON MIDDLE SCHOOL
BOILER REPLACEMENT
1225 N BROAD STREET, MERIDEN CT 06450**

3. Analysis must indicate dead loads, derived loads, and materials used for connections to equipment and structure. Analysis must detail anchoring methods, bolt diameters, embedment, and weld length.
 4. A seismic design errors and omissions insurance certificate must accompany submittals.
- D. Submit drawings showing locations of all seismic restraints for equipment, piping, and conduit provided under Sections 15 and 16:
1. The term EQUIPMENT includes ALL non-structural components. These specifications are applicable within the facility and 5 feet outside of the foundation wall. Equipment buried underground is excluded but entry of services through the foundation wall is included. Equipment referred to below is a partial list; (equipment not listed is still included in this specification).
- | | |
|----------------|--------------|
| Air Separators | Water Heater |
| Piping | Boiler |
- E. Submittals shall include a listing of all isolated and non-isolated equipment to be restrained.
- F. Seismic restraints shall not be required for the following installations:
1. Piping in mechanical rooms less than 1 1/4-inch inside diameter.
 2. All other piping less than 2 1/2-inch inside diameter.
 3. All electrical conduit less than 2 1/2-inch inside diameter.
 4. All rectangular air-handling ducts less than 6 square feet in cross-sectional area.
 5. All round air-handling ducts less than 28 inches in diameter.
 6. All piping suspended by individual hangers 12 inches or less in length from the top of the pipe to the bottom of the support for the hanger.
 7. All ducts suspended by hangers 12 inches or less in length from the top of the duct to the bottom of the support for the hanger.
- G. Life safety systems defined:
1. All systems involved with fire protection including sprinkler piping, service water supply piping, fire dampers and smoke exhaust systems.
 2. All systems involved with and/or connected to emergency power supply including all generators, transfer switches, transformers and all flowpaths to fire protection and/or emergency lighting systems.
 3. Fresh air relief systems on emergency control sequence including air handlers, conduit, duct, dampers, etc.

3.4 COOPERATION WITH OTHER TRADES:

- A. No piping, conduit, valves, boxes, etc., shall be installed until the entire run has been checked for clearance and the work has been coordinated between all the trades. Each tradesman shall be responsible for taking his own field measurements and maintaining proper clearance from the City of Meriden's equipment and the work of other trades, and for coordinating his work with that of other Contractors and The City of Meriden. Furnish all necessary information, dimensions, templates, etc. in order that a perfectly coordinated job will result.

**WASHINGTON MIDDLE SCHOOL
BOILER REPLACEMENT
1225 N BROAD STREET, MERIDEN CT 06450**

- B. Contractor shall carry out his work in conjunction with other trades and shall give full cooperation to other trades. Contractor shall furnish all information necessary to permit work of all trades to be installed in a satisfactory manner.
- C. Where space is so limited that Contractor's work shall be installed in close proximity to the work of other trades or where it is evident that Contractor's work will interfere with other trades, he shall assist in working out space conditions to make satisfactory adjustments. If required or directed by Engineer, the Contractor shall prepare composite working drawings and sections of not less than 3/4" -1'-0" scale clearly showing how his work is to be installed in conjunction with other trades; he shall make corrections necessary to satisfactorily complete installation at no additional cost to The City of Meriden.
- D. All supports for hanging material to be connected to steel structure shall be installed prior to installation of fire proofing material. Any damage to fireproofing caused by late installation of hanging material shall be repaired by the Fire-proofing Contractor at the expense of the Contractor responsible.
- E. The Heating Contractors shall give to the Electrical Contractor all information on switches, controls, pilots, etc. furnished under the Heating Contracts, together with makes and catalog numbers where required to permit the Electrical Contractor to leave the proper boxes to receive same. This information shall be given well in advance so that the Electrical Contractor may install his work as construction progresses. In the event that this information is not given in time to permit the Electrical Contractor to leave proper boxes, etc. as construction progresses, it shall be the responsibility of the Contractor to pay all costs of cutting and patching.

3.6 INFORMATION FOR ELECTRICAL CONTRACTOR:

- A. Deliver to the Electrical Contractor all information on motors and controls furnished under the Mechanical Contract, together with makes and catalog numbers, to permit the Electrical Contractor to leave the proper boxes and wiring.

3.7 SLEEVES, INSERTS AND ANCHOR BOLTS:

- A. All pipes and conduits passing through floors, walls or partitions shall be provided with sleeves sized to give a minimum of 1/2" clearance between sleeve and the outside diameter of the pipe, conduit or insulation, enclosing the pipe or conduit.
- B. Sleeves through concrete floors or interior masonry walls shall be Schedule 40 steel pipe, set flush with finished wall or ceiling surfaces, but extending 2 inches above finished floors or shall be in accordance with details on drawings. In all mechanical equipment rooms sleeves shall extend 6 inches above finished floor.
- C. Inserts shall be individual or strip type of steel or malleable iron construction for removable nuts and threaded rods up to 3/4" diameter, permitting lateral adjustment.

3.8 FIRE STOPPING:

A. General

1. Firestopping: Material or combination of materials used to retain integrity of fire-rated construction by maintaining an effective barrier against the spread of flame, smoke, and hot gases through penetrations in fire rated wall and floor assemblies.

B. General Description of The Work

1. Only tested firestop systems shall be used in specific locations as follows:
Penetrations for the passage of duct, cable, cable tray, conduit, piping, electrical busways and raceways through fire-rated vertical barriers (walls and partitions), horizontal barriers (floor/ceiling assemblies), and vertical service shaft walls and partitions.

C. References

1. Test Requirements: ASTM E-814, "Standard Method of Fire Tests of Through Penetration Fire Stops" (July 1997).
2. Underwriters Laboratories (UL) of Northbrook, IL runs ASTM E-814 under their designation of UL 1479 and publishes the results in their "FIRE RESISTANCE DIRECTORY" that is updated annually.
3. International Firestop Council Guidelines for Evaluating Firestop Systems Engineering Judgments
4. Test Requirements: ASTM E 84-96, "Surface burning characteristics".
5. All major building codes: ICBO, SBCCI, BOCA, and IBC.
6. Test Requirements: ASTM E-119, "Fire Test of Building Construction and Materials" (UL 263)

D. Quality Assurance

1. Firestop System installation must meet requirements of ASTM E-119, ASTM E-814, ASTM E-84-96, UL 236, UL 1479 or UL 2079 tested assemblies that provide a fire rating equal to that of construction being penetrated.
2. Firestop Systems do not reestablish the structural integrity of load bearing partitions/assemblies, or support live loads and traffic. Installer shall consult the structural engineer prior to penetrating any load bearing assembly.

E. Submittals

1. Submit Product Data: Manufacturer's specifications and technical data for each material including the composition and limitations, documentation of UL firestop systems to be used and manufacturer's installation instructions to comply with Section 1300.
2. Submit material safety data sheets provided with product delivered to job-site.

F. Installer Qualifications

1. Engage an experienced Installer who is certified, licensed, or otherwise qualified by the firestopping manufacturer as having been provided the necessary training to install manufacture's products per specified requirements.

G. Products, General

1. Provide firestopping composed of components that are compatible with each other, the substrates forming openings, and the items, if any, penetrating the firestopping under conditions of service and application, as demonstrated by the firestopping manufacturer based on testing and field experience.
2. Provide components for each firestopping system that are needed to install fill material. Use only components specified by the firestopping manufacturer and approved by the qualified testing agency for the designated fire-resistance-rated systems.
3. Firestopping Materials are either "cast-in-place" (integral with concrete placement) or "post installed." Provide cast-in-place firestop devices prior to concrete placement.

H. Acceptable Manufacturers

1. Subject to compliance with through penetration firestop systems (XHEZ) and joint systems (XHBN) listed in Volume II of the UL Fire Resistance Directory, provide products of the following manufacturers as identified below:
 - a. Hilti, Inc., Tulsa, Oklahoma 800-879-8000
 - b. Other manufacturers listed in the U.L. Fire Resistance Directory – Volume

I. Materials

1. Use only firestop products that have been UL 1479, ASTM E-814, or UL 2079 tested for specific fire-rated construction conditions conforming to construction assembly type, penetrating item type, annular space requirements, and fire-rating involved for each separate instance.
2. Provide a firestop system with a "F" Rating as determined by UL 1479 or ASTM E814 which is equal to the time rating of construction being penetrated.
3. Provide a firestop system with an Assembly Rating as determined by UL 2079 which is equal to the time rating of construction being penetrated.

J. Preparation

1. Verification of Conditions: Examine areas and conditions under which work is to be performed and identify conditions detrimental to proper or timely completion.
 - a. Verify penetrations are properly sized and in suitable condition for application of materials.

**WASHINGTON MIDDLE SCHOOL
BOILER REPLACEMENT
1225 N BROAD STREET, MERIDEN CT 06450**

- b. Surfaces to which firestop materials will be applied shall be free of dirt, grease, oil, rust, laitance, release agents, water repellents, and any other substances that may affect proper adhesion.
- c. Provide masking and temporary covering to prevent soiling of adjacent surfaces by firestopping materials.
- d. Comply with manufacturer's recommendations for temperature and humidity conditions before, during and after installation of firestopping.
- e. Do not proceed until unsatisfactory conditions have been corrected.

K Coordination

1. Coordinate location and proper selection of cast-in-place Firestop Devices with trade responsible for the work. Ensure device is installed before placement of concrete.
2. Responsible trade to provide adequate spacing of field run pipes to allow for installation of cast-in-place firestop devices without interferences.

L. Installation

1. Regulatory Requirements: Install firestop materials in accordance with UL Fire Resistance Directory.
2. Manufacturer's Instructions: Comply with manufacturer's instructions for installation of through-penetration and construction joint materials.
 - a. Seal all holes or voids made by penetrations to ensure an air and water resistant seal.
 - b. Consult with project manager and damper manufacturer prior to installation of UL firestop systems that might hamper the performance of fire dampers as it pertains to duct work.
 - c. Protect materials from damage on surfaces subjected to traffic.

M. Field Quality Control

1. Examine sealed penetration areas to ensure proper installation before concealing or enclosing areas.
2. Keep areas of work accessible until inspection by applicable code authorities.
3. Perform under this section patching and repairing of firestopping caused by cutting or penetrating of existing firestop systems already installed by other trades.

N. Adjusting and Cleaning

1. Remove equipment, materials and debris, leaving area in undamaged, clean condition.
2. Clean all surfaces adjacent to sealed holes and joints to be free of excess firestop materials and soiling as work progresses.

3.9 ACCESSIBILITY:

- A. Locate all equipment which must be serviced, operated or maintained in fully accessible positions. Equipment shall include but not be limited to motors, controllers, switchgear, drain points, etc.

**WASHINGTON MIDDLE SCHOOL
BOILER REPLACEMENT
1225 N BROAD STREET, MERIDEN CT 06450**

- B. In the event that any equipment is not installed to permit convenient servicing, disassemble, removal of parts, etc. the Contractor shall, at his own expense, make all corrections necessary to accomplish this.

3.10 LUBRICATION:

- A. All equipment having moving parts and requiring lubrication which is installed under this Contract, shall be properly lubricated according to manufacturer's recommendations prior to testing and operation. Any such equipment discovered to have been operated before lubrication is subject to rejection and replacement at no cost to the City of Meriden. Units furnished with sealed bearings are accepted.

3.11 TAGS, CHARTS AND NAMEPLATES:

- A. Each valve, control, switch, electrical panel, motor and any piece of apparatus installed under these sections shall be properly identified.
- B. Each sectional shutoff valve shall have a brass tag with identifying number. Tag shall be secured to valve stem with sufficient length of copper coated jack chain to allow tag to be easily read.
- C. All other equipment, including panels and switches, shall be proved with a suitable laminated plastic nameplate fastened with screws or rivets. Small equipment labels may use a pressure sensitive tape.
- D. All nameplates and labels shall identify components by proper nomenclature and numbered according to equipment schedule or as designated.
- E. Charts shall be furnished in duplicate and shall include the valve identification number, location and purpose. One chart shall be mounted in frame with a clear glass front and secured to wall in location directed.
Second chart shall be for use throughout building and shall be provided with transparent plastic closure for top and attached 8" bead chain for hanging. Holes to be reinforced with brass grommets. Tags and closures as manufactured by Seton Name Plate Corp., New Haven, Conn., or approved equal.

3.12 INSTRUCTIONS:

- A. Prepare written instructions frames for the proper maintenance and operation of any special equipment furnished and installed under this Contract.
- B. Personally instruct the City of Meriden's Custodian or official representative in addition to furnishing all manuals, diagrams, etc. in the proper operation and maintenance of all equipment and piping installed under this Contract.
- C. Prepare a portfolio with all tags, operating manuals, parts lists, guarantees, etc. that are packed with all equipment furnished under this Contract and submit same to the Engineer.

**WASHINGTON MIDDLE SCHOOL
BOILER REPLACEMENT
1225 N BROAD STREET, MERIDEN CT 06450**

3.13 PIPING CODE MARKERS:

- A. All service piping which is accessible for maintenance operations shall be identified with vinyl plastic color bands and legends at each branch and riser take-off, at each passage through wall, floor and ceiling, adjacent to each valve and on all pipe runs marked each 20'-0". Pipe markers to conform to A.S.A. Bulletin A-13. Where pipes are too small for legends, brass identification tags 1-1/2" in diameter with depressed 1/2" high black filled letters shall be fastened with chain. Pipe markers and tags as manufactured by the Seton Name Plate Corp., New Haven, Conn., or equal approved.

3.14 CLEANING PIPING, CONDUITS AND EQUIPMENT:

- A. Thoroughly clean all piping and equipment of all foreign substances inside and out before being placed in operation.
- B. If any part of a system should be stopped by any foreign matter after being placed in operation, the system shall be disconnected, cleaned and reconnected wherever necessary to locate and remove obstructions.
Any work damaged in the course of removing obstructions shall be repaired or replaced when the system is reconnected at no additional cost to the City of Meriden.
- C. During the course of construction, all pipe and electrical conduits shall be capped in an approved manner to insure adequate protection against the entrance of foreign matter.

3.15 CLEANING UP:

- A. After completion of the work, remove all waste, rubbish and other materials left as a result of operations and leave the premises in clean condition.
- B. All fixtures, equipment, etc. installed under the Mechanical and Electrical Sections shall be free of dirt, grease and other foreign material and left in perfectly clean condition and ready to use.

3.16 GUARANTEE:

- A. All parts of the work and all equipment shall be guaranteed for a period of 18 months from the date of acceptance of the job by the City of Meriden.
- B. If during that period of general guarantee, any part of the work installed fails, becomes unsatisfactory or does not function properly due to any fault in material or workmanship, whether or not manufactured or job built, each section shall upon notice from the City of Meriden, promptly proceed to repair or replace such faulty material or workmanship without expense to the City of Meriden, including cutting, patching and painting or any other work involved and including repair or restoration of any damaged sections of the premises resulting from such faults.
- C. In the event, that a repetition of any one defect occurs, indicating the probability of further failure, and which can be traced to faulty design, material or workmanship, then repairs or replacement shall not continue to be made but, the fault shall be remedied by a complete replacement of the entire defective unit.

**WASHINGTON MIDDLE SCHOOL
BOILER REPLACEMENT
1225 N BROAD STREET, MERIDEN CT 06450**

- D. In addition to the general guarantee, obtain and transmit to the City of Meriden any guarantees or warranties from manufacturers of specialties but only as a supplement to the general guarantee which will not be invalidated by same.

3.17 THE CITY OF MERIDEN'S INSTRUCTIONS AND SYSTEM OPERATION:

- A. At the time of the job's acceptance by the City of Meriden, Contractor shall furnish maintenance and operating instructions for all equipment including parts list. These instructions shall be written in layman's language and shall be inserted in vinyl covered three-ring loose leaf binder. This information in binder shall be first sent to the approved by the Engineer before turning over to the City of Meriden.
- B. Upon completion of all work and of all tests, each Division shall furnish the necessary skilled labor and helpers for operating the system and equipment for a period of one (1) day of eight (8) hours, or in two (4) hours separate sessions. During this period, instruct the The City of Meriden or his representative fully in operation, adjustment and maintenance of all equipment furnished. Give at least forty-eight (48) hours notice to the City of Meriden in advance of this period.

3.18 THE CITY OF MERIDEN'S ACCEPTANCE TEST:

- A. After the various systems are complete as determined by preliminary operating tests, the Contractor shall arrange for the City of Meriden's final acceptance tests.
- B. The Contractor shall have present at each acceptance test, representatives of the several Contractors whose work is directly or indirectly involved, with instruments as necessary in accordance with the design and to include the following.
 - 1. All equipment installed and operating in accordance with manufacturer's instructions and performance guarantee.
 - 2. All systems operating in accordance with specifications.
 - 3. All distribution systems properly adjusted for distribution to equipment as specified.
 - 4. The various systems properly flushed, cleaned, and free of entrapped air and dirt.
 - 5. All motors installed with proper thermal overload protection and not operating under overload conditions as determined by ammeter readings.
 - 6. All valve charts, etc. as specified in various parts of the specifications installed or ready for delivery to the City of Meriden.
- C. The date of the City of Meriden' acceptance of the equipment shall be the start of the one year guarantee period.

3.19 TEST:

- A. Conducting Tests: Conduct all tests called for under the various sections or as required and repair or replace any defects. Perform all tests in the presence of and to the satisfaction of the Engineer and such other parties as may have legal jurisdiction.
- B. Defective Work: The City of Meriden shall have the privilege of stopping any of the work not being properly installed. All such defective work shall be repaired or replaced and the tests shall be repeated.

**WASHINGTON MIDDLE SCHOOL
BOILER REPLACEMENT
1225 N BROAD STREET, MERIDEN CT 06450**

- C. Repair Damaged Work: Repair all damages resulting from tests and replace damaged materials.

END OF SECTION 20 00 50

**WASHINGTON MIDDLE SCHOOL
BOILER REPLACEMENT
1225 N BROAD STREET, MERIDEN CT 06450**

SECTION 22 05 00

COMMON WORK RESULTS FOR PLUMBING

PART 1 - GENERAL

1.1 RELATED DOCUMENTS:

- A. The General Provisions of the Contract, including General and Supplementary Conditions and General Requirements, apply to the work specified in this Section.
- B. The General Requirements in Section 200050 shall also govern the work under this section.

1.2 SCOPE OF WORK:

Gas systems
Domestic water systems

- A. This contract includes all labor, material, equipment, tests and appliances required to furnish and install all plumbing as shown on drawings, implied and herein specified.
- B. The location of the building will be as shown on drawings. A visit to the site and examination of other Mechanical trades showing all details of construction is a requirement before submitting a proposal.
- C. The drawings are diagrammatic and indicate the general arrangement of piping and equipment, and do not show all minor details and fittings. Such items shall be included, as well as reasonable modifications, in the layout as directed to prevent conflict with other trades.
- D. Connect all equipment shown on drawings. Check all Mechanical drawings and coordinate all the work accordingly.
- E. Provide seismic restraints in accordance with Section 230548.

1.3 QUALITY ASSURANCE:

- A. Codes and Standards: All work shall comply with the Connecticut State Building Code, BOCA Plumbing Code, and NFPA Standards.
 - 1. 2022 Connecticut State Building Code with all the Amendments.
 - 2. 2021 International Building Code
 - 3. 2021 Life Safety Code- NFPA 101
 - 4. 2021 International Plumbing Code
 - 5. 2021 International Mechanical Code
 - 6. 2021 National Fuel Gas Code-NFPA 54.
 - 7. 2021 International Energy Conservation Code
 - 8. State of Connecticut Public Health Code
 - 9. 2017 Accessible and Usable Buildings and Facilities - ICC/ANSI A117.1
 - 10. Americans with Disabilities Act – ADA

**WASHINGTON MIDDLE SCHOOL
BOILER REPLACEMENT
1225 N BROAD STREET, MERIDEN CT 06450**

1.4 SUBMITTALS:

- A. Shop Drawings: Submit the following shop drawings:

Valves
Pipes, fittings and couplings
Hangers and supports

1.5 PLUMBING SYSTEM DESCRIPTION:

- A. Furnish and install all plumbing equipment shown on the drawings and herein specified. All equipment shall be complete and perfect and properly connected to water supply as required and left in complete operation.
- B. Before ordering equipment, Contractor shall submit brochures of all equipment and trim to the Engineer for review.
- C. Contractor shall include all permit fees and connection charges.

1.6 WATER SERVICE:

- A. Refer to drawings for service location. This Contractor shall make closing connection to existing water service. All work shall comply with the Local Water Company requirements.

PART 2 - PRODUCTS

2.1 PIPE AND FITTINGS:

- A. Listed below are references to the specification standards or recognized authorities to which pipe and fitting materials must conform.
- B. All reference shall be the current edition as recognized by the active codes. Each pipe length shall have the manufacturer's name cast, stamped or rolled on. Each fitting shall have the manufacturer's symbol and pressure rating cast, stamped or rolled on.
- C. Copper Tubing: shall be Type "K" or "L" seamless conforming to ASTM B 88. Cast bronze fittings to conform to ANSI B16.18 and wrought copper fittings to conform to ANSI B16.22.
- D. Solder: To be 95% tin, 5% antimony (lead free) conforming to ASTM B-32, grade 5A.
- E. Gas Piping:
1. The pipe shall be steel pipe, Schedule 40 complying with the ASTM A 53 Specification for Pipe, Steel, Black and hot-dipped, Zinc-Coated Welded and Seamless. The fittings shall be steel, malleable iron or ductile iron.
 2. Gas pipe shall be clear and free from cutting burrs and defects. Any defective pipe or fitting shall be replaced and shall not be repaired.

**WASHINGTON MIDDLE SCHOOL
BOILER REPLACEMENT
1225 N BROAD STREET, MERIDEN CT 06450**

3. Provide gas valves at all pressure regulators, at each piece of equipment, as shown on drawings and as required by codes. Gas solenoid valve for Kitchen is to be normally closed. Size as indicated on drawings.
4. No branch lines shall be taken from the bottom of horizontal runs.
5. Provide drips at any points in line where condensate may collect.
6. All gas piping shall be graded not less than 1/4" in 15'-0". All horizontal piping shall be graded to risers; provide capped drip at bottom of riser.
7. Provide dirt legs, gas valves, and unions at each equipment connection.

2.2 HANGERS:

- A. Securely hang and anchor pipe as shown and required with proper provision for expansion, contraction and elimination of undue stress and strain on piping.
- B. Provide a pipe hanger within two (2) feet of each elbow, tee, wye, valve, strainer and similar device.
- C. Secure and support runs at base and at sufficiently close intervals to hold pipe at alignment and to carry safely the weight of piping and contents without undue stress thereon.
- D. Except as indicated to the contrary, secure and support all horizontal piping as follows and required to prevent sagging, undue pipe movement and preserve proper alignment in each run.

<u>Piping</u>	<u>Size</u>	<u>Maximum Interval</u>
Steel	2" & smaller	Six (6) feet
Steel	2 1/2" & larger	Ten (10) feet
Copper Tubing	1 1/4" & smaller	Five (5) feet
Copper Tubing	1 1/2" & larger	Eight (8) feet

- E. Hangers up to and including 2" shall be the adjustable band type equal to Empire. Figure 310 for iron pipe and Fig. 310CT for copper tubing.
- F. Hangers for piping 2-1/2" and up shall be the clevis type, equal to Empire. Figure 11 for iron pipe and Figure 110CT for copper tubing.
- G. Hangers shall be suspended from one of the following devices:
 1. "C" clamps.
 2. Trapeze hanger assemblies consisting of back-to-back horizontal steel channels with end-type rod hangers.
 3. Expansion shield embedded into concrete or masonry.
- H. Provide seismic restraints in accordance with Section 15010.

**WASHINGTON MIDDLE SCHOOL
BOILER REPLACEMENT
1225 N BROAD STREET, MERIDEN CT 06450**

2.3 INSULATION:

- A. Refer to Section 22 07 00.

2.4 VALVES:

- A. This Contractor shall furnish and install valves where shown on plans and also wherever necessary to make the system complete in its operation. All valves shall be as manufactured by Stockham, Jamesbury, Appollo, Centerline or Milwaukee as specified.

Hot water and cold water (domestic)

2" and smaller

Ball valves	Apollo - 71-100/200
Check valves	Stockham B-310-T

2-1/2" and larger

Butterfly valves	Stockham - LG712-BS3-B (Lug Style)
Check valves	Centerline - CLC - S.S. plates and spring nypalon seats

Furnish all valve materials suitable for service intended.

2.5 BACKFLOW PREVENRTERS:

- A. 4" Reduced pressure Zone Assembly: Watts Model 957RPDA with non-rising stem gate valves, UL classified and FM approved. Provide with air gap fitting.
- B. 3/4", 1", & 2" Reduced pressure Zone Assemblies: Watts Model 909 with ball valves. Provide with air gap fitting.
- C. 1/2" Reduced pressure Zone Assembly: Watts Model 009 with ball valves valves, UL classified. Provide with air gap fitting.

PART 3 - EXECUTION

3.1 INSTALLATION:

- A. Check all plumbing and electrical drawings to make sure that this piping will not conflict with other work.
- B. All piping work shall be installed with provisions to allow for expansion and contraction of lines so as to prevent any undue strains on pipe and fittings, any trapping of lines or lifting or dislocating of any appliances.
Rectify without cost to the City of Meriden any conditions of noisy circulation due to trapped or air bound lines, including the expense of cutting and repairing of the building structure incident to making such alterations.

**WASHINGTON MIDDLE SCHOOL
BOILER REPLACEMENT
1225 N BROAD STREET, MERIDEN CT 06450**

- C. Install the work to conform to space conditions and the work of other trades. The drawings indicate generally the runs and the sizes of piping and although the size must not be decreased, nor the drawings deviated from except as unforeseen space conditions may require, the right is reserved to make minor changes in the arrangement of the work to meet the conditions arising during construction.

3.2 TESTS:

- A. Furnish all labor and materials for the performance of all tests as required by codes and by the authorized inspectors having jurisdiction.

3.3 HOT WATER PIPING:

- A. Extend the hot water piping as shown on plans which, in general, will follow the cold water.
- B. At low points, provide valved drain with hose connection with vacuum breaker.
- C. Pipe shall be copper Type “K” or “L” with wrought copper sweat fittings.

3.5 COLD WATER PIPING:

- A. Extend cold water piping as shown on plans.
- B. At low points, provide valved drain with hose connection with vacuum breaker.
- C. Pipe shall be copper type “K” or “L”.

3.6 FUEL GAS PIPING:

- A. Pressure Testing
 - 1. The customer piping shall be pressure tested in accordance with the National Fuel Gas Code (NFPA_54), current edition. The test medium shall be nitrogen (N2), carbon dioxide (CO2) or air. The test pressure and duration shall conform to NFPA-54 Section 4.14 and must be approved by the local authority having jurisdiction and the Local Gas Distribution Company (LDC).
- B. Purging and Placing Gas Piping into Operation
 - 1. Upon notification and meter being turned on by Local Distribution Gas Company, the house line can be placed in operation. All purging shall be done in accordance with NFPA-54 Section 4.3.2.
 - a. The air can be safely displaced with natural gas provided that a moderately rapid and continuous flow of gas is introduced at the meter and air is vented to the outside of the building by means of connecting a rigid pipe or a semi-rigid metallic tubing with appropriate fittings.
 - b. The purge piping must be located outside of the building at a safe distance away from fresh air intakes and away from any source of ignition. The end of the purge riser must be equipped with a flash back arrestor. The

**WASHINGTON MIDDLE SCHOOL
BOILER REPLACEMENT
1225 N BROAD STREET, MERIDEN CT 06450**

purge riser must be manned at all times. A fire extinguisher must be placed nearby while purging is in operation. A combustion gas indicator (CGI) can be used to assure the house line is purged properly to 100% gas.

- c. In the event of multi-floor house lines, the longest house line (furthest from the meter) must be purged first, followed by the next longest, until all sections of house lines have been purged to 100% gas.

C. Odorant Level

1. All house lines must be continuously purged until such time that the Odorant level is sufficiently detachable by smell and confirmed with an ordinary level instrument such as Bacharach Model 5110-200, or equivalent.
The instrument shall have a range of to 1.2% gas in air. The line must be purged until a readily detachable Odorant reading of 0.25% or less gas in air is maintained.
 - a. As soon as the acceptable level reading is maintained at all purging locations, turnoff the ends of house lines, disconnect the purging tubing, permanently plug all ends and leak test all plugs. Gas utilization equipment can now be purged and placed into operation.
 - b. Odorant level readings shall be re-taken periodically to ensure proper level of Odorant is maintained. Odorant level may decay especially in low flow house lines. If this occurs purging procedure must be repeated as needed.

**WASHINGTON MIDDLE SCHOOL
BOILER REPLACEMENT
1225 N BROAD STREET, MERIDEN CT 06450**

3.7 PIPING JOINTS:

- A. Soldered Joints in Copper Tube: Cut the ends of tubes square, remove burrs, clean tube ends and fitting sockets with emery cloth, and remove all particles before applying flux and making the joint. Insert tubes to full socket depth. Use the following solders at the given conditions.
- B. All solder joints shall be made up with 95/5 solder.
- C. Plumbing Contractor shall be held responsible for any damages caused by water from poorly made joint.

3.8 REAMING OF PIPES:

- A. All pipes to be carefully reamed after cutting and threading.
- B. All steel pipe lines shall be reamed carefully before they are threaded. They shall be reamed smooth on the inside to give the full area of pipe in all cases.
- C. All copper tubing shall be carefully cut square and true, carefully reamed and thoroughly cleaned. The inside of fittings shall be carefully cleaned. All tubing shall be inserted fully to the shoulder of fittings.

3.9 TESTING:

- A. All piping testing to be performed in accordance with all applicable Codes including, but not limited to IFC and CT Health Code.
- B. All involved parties are to be notified at least two weeks in advance of a scheduled test.

3.10 DISINFECTION:

- A. Disinfect new water piping in accordance with AWWA C601.
 - 1. The pipe system shall be flushed with clean, potable water until dirty water does not appear at the points of outlet.
 - 2. The system or part thereof shall be filled with a water/chlorine solution containing at least 50 parts per million (50mg/L) of chlorine, and the system or part thereof shall be valved off and allowed to stand for 24 hours; or the system or part thereof shall be filled with water/chlorine solution containing at least 200 parts per million (200mg/L) of chlorine and allowed to stand for 3 hours.
 - 3. Following the required standing time, the system shall be flushed with clean potable water until the chlorine is purged from the system.
 - 4. The procedure shall be repeated where shown by a bacteriological examination that contamination remains present in the system.
 - 5. After completion take bacteriological samples to provide a record by which the effectiveness of the procedure can be determined.

END OF SECTION 22 05 00

PART 1 - GENERAL

1.1 RELATED DOCUMENTS:

- A. The General Provisions of the Contract, including General and Supplementary Conditions and Division 01, General requirements, apply to the work specified in this Section.
- B. The requirements in Section 22 05 00 shall also govern the work under this Section.
- C. Scope of Work: This Section contains details for the insulation of pipe and equipment installed under Division 22.

1.2 SUBMITTALS:

- A. In accordance with Section 20 00 50, the following items shall be submitted for approval.
 - Piping insulation
 - Fitting insulation
 - Equipment insulation
- B. Recycled Content: Provide data showing recycled materials content of materials and fabricated items provided for this project, stated as a percentage of the materials included in these items or materials provided as part of the Work of this Section.

1.3 MECHANICAL SYSTEMS INSULATION:

- A. Furnish and install all thermal and protective insulation as specified herein for piping and equipment as shown on the drawings.
- B. The following mechanical items shall be insulated:
 - Piping – hot, recirculated hot, cold and horizontal storm drain
 - Fittings - Valve bodies, Victaulic couplings, elbows, tees, etc.
 - Equipment insulation

1.4 SYSTEM PERFORMANCE

- A. Insulation materials furnished and installed hereunder should meet the minimum thickness requirements of ASHRAE 90.1 (2013), "Energy Efficient Design of New Buildings," of the American Society of Heating, Refrigeration, and Air Conditioning Engineers. However, if other factors such as condensation control or personnel protection are to be considered, the selection of the thickness of insulation should satisfy the controlling factor.
- B. Insulation materials furnished and installed hereunder shall comply with NFPA 255 and shall have a maximum flame spread index of 25 and a maximum smoke developed index of 50 when tested in accordance with the following testing standard:

Underwriters' Laboratories, Inc. UL 723

**WASHINGTON MIDDLE SCHOOL
BOILER REPLACEMENT
1225 N BROAD STREET, MERIDEN CT 06450**

Adhesives used for applying the sealed jackets shall also conform to these same ratings. The use of wheat paste or any other material not meeting these requirements will not be allowed.

1.5 QUALITY ASSURANCE

- A. Insulation materials and accessories furnished and installed hereunder shall, where required, be accompanied by manufacturers' current submittal or data sheets showing compliance with applicable specifications.
- B. Insulation materials and accessories shall be installed in a workmanlike manner by skilled and experienced workers who are regularly engaged in commercial insulation work.
- C. All covering and insulating materials shall be manufactured by Johns Manville, Knauf, Owens-Corning or Armstrong.

1.6 DELIVERY AND STORAGE OF MATERIALS

- A. All of the insulation materials and accessories covered by this specification shall be delivered to the job site and stored in a safe, dry place with appropriate labels and/or other product identification.
- B. The contractor shall use whatever means are necessary to protect the insulation materials and accessories (wick material, sealing tape, etc) before, during, and after installation. No insulation material shall be installed that has become damaged in any way. The contractor shall also use all means necessary to protect work and materials installed by other trades.

PART 2 – PRODUCTS

2.1 PIPING:

- A. Insulate all new domestic hot, cold and recirculating hot water lines with Johns Manville Fiberglass ASJ with S.S.L. II, pipe insulation with double self-sealing lap having a factory applied jacket. All horizontal and vertical insulated piping located below 8'-0" AFF level and not protected with enclosures shall be protected with Zeston 2000 P.V.C. 30 Mil jacketing. Outdoor, exposed piping shall be protected with aluminum jacket. All horizontal and vertical insulated pipes located in the Boiler Room shall be protected with color coded Zeston 300 Series 30 Mil jacket. Acceptable equals are by SpeedLine or Proto.
- B. All concealed piping shall be covered as follows: Apply insulation to clean dry pipe with side and end joints butted tightly. Seal lap of jacket and butt joint strips with Benjamin Foster 82-07 vapor barrier lap adhesive. Insulate fittings, flanges and valves of piping with mitered pipe insulation, or F/G premolded fittings made smooth with insulating cement and jacket with glass cloth saturated with Benjamin Foster 30-60 lagging adhesive. Vinyl or plastic fitting jackets will be allowed.
- C. Insulate domestic cold water, water cooler waste, rain leaders, roof drain pans (70 degrees F. and below) in the same as for hot piping above except vapor seal all joints, seams, elbows and fittings.
- D. Insulate horizontal rain leaders with A.S.J. - S.S.L. II pipe insulation with double self-sealing lap and vapor barrier. Include roof drain bowl and first vertical drop.

**WASHINGTON MIDDLE SCHOOL
BOILER REPLACEMENT
1225 N BROAD STREET, MERIDEN CT 06450**

- E. For all insulated pipes exposed to weather apply a 16 mil embossed aluminum jacket with 2" overlap at longitudinal and circumferential joints. Secure in place with 3/4" x .015" aluminum band 18" on centers. All seams shall be sealed weather tight.
- F. Foam insulation:
 - 1. Piping and Fittings. MicroLok plain pipe insulation shall be wired or taped in place over clean, dry pipe with all joints butted firmly together. Vapor retarder shall be Micro-Lok AP-T plus.
 - 2. The insulation shall be finished with metal jacketing with a laminated moisture retarder. Metal jacketing shall be overlapped 2 to 3 inches (51 to 76 mm) and held in place with sheet metal screws or metal bands.
 - 3. Elbows and tees shall be finished with matching metal fitting covers. Other fittings in metal-jacketed systems shall be finished with conventional weather-resistant insulating materials with painted aluminum finish.
- G. Provide minimum insulation thickness in accordance with the following table.
Minimum Pipe Insulation

Piping System Types	Fluid Temp. Range	Runouts 2 in +	1 in. and less	1-1/4 to 2 in.	2-1/2 to 4 in.	5 and Larger
	F	in.	in.	in.	in.	in.
Plumbing Systems						
Hot Water	100-200	1.0	1.5	1.5	2	2
Cold Water	Below 70	0.5	1.5	1.5	1.5	1.5

Reinsulate piping where insulation has been disturbed under this contract and feather to remaining insulation.

2.2 FITTING COVERS:

- A. Fitting covers may be used in lieu of insulating cement and jacket. Provide fitting covers in Zeston - 2000 P.V.C. (20 Mil thickness) by Johns Manville. Provide color coded fitting covers in Zeston 300 Series 30 Mil jacket for fittings located in the Boiler Rooms. Acceptable substitutions are by SpeedLine or Proto.
- B. General - The matching insert (fiberglass) should either be wrapped completely around the fitting or snugly positioned inside the fitting for proper fit. The insert shall cover the full inner surface area of the fitting cover. The fitting cover is then to be applied over the fitting and insert, and the throat secured by either tack fastening, taping, or banding.
- C. Cold Pipe - Fitting systems below ambient temperature must have a continuous vapor barrier, either with pressure sensitive PVC Tape, or an approved adhesive system. When PVC Tape is

**WASHINGTON MIDDLE SCHOOL
BOILER REPLACEMENT
1225 N BROAD STREET, MERIDEN CT 06450**

used, a 2" downward lap is required. On cold lines in severe ambient temperatures, the fiberglass insert shall be the same thickness as the adjacent pipe insulation. All joints shall then be sealed with PVC Tape.

- C. Hot Pipe - For hot piping which requires pipe insulation over 1-1/2" wall, an extra inch of wall thickness in the pipe insulation shall be applied. If the surface temperature of insulation exceeds 155 degrees F. fitting covers should not be used. The throat seam shall be riveted or tacked on hot piping.

2.3 COMBUSTION AIR PIPE:

- A. Insulate combustion air pipe in Mechanical Room with 1" thick, R-5, fiberglass ASJ-25 equipment insulation.
- B. Insulation shall be cut to fit the shape and contour of the equipment. All voids between pipe surface and insulation shall be packed with light density fiberglass. Impale insulation over welded pins on 12" centers and secure in place with speed washers.
- C. The insulation shall be vapor sealed to provide a complete airtight envelope. Vapor barrier shall consist of one layer of Ludlow Foil Barrier Paper smoothly adhered to the insulation or cement surface with Benjamin Foster 82-07 Vapor Barrier Lap Adhesive.

PART 3 – EXECUTION

3.1 SITE INSPECTION

- A. Before starting work under this section, carefully inspect the site and installed work of other trades and verify that such work is complete to the point where installation of materials and accessories under this section can begin.
- B. Verify that all materials and accessories can be installed in accordance with project drawings and specifications and material manufacturer's recommendations.
- C. Verify, by inspecting product labeling, submittal data, and/or certifications which may accompany the shipments, that all materials and accessories to be installed on the project comply with applicable specifications and standards and meet specified thermal and physical properties.

3.2 PREPARATION

- A. Ensure that insulation is clean, dry, and in good mechanical condition and that all factory-applied facings are intact and undamaged. Wet, dirty, or damaged insulation is not acceptable for installation.
- B. Ensure that pressure testing of piping, duct and fittings has been completed prior to installing insulation.

3.3 INSTALLATION

A. General

1. Install all insulation materials and accessories in accordance with manufacturer's published instructions and recognized industry practices to ensure that it will serve its intended purpose.
2. Install insulation on piping/duct subsequent to painting, and acceptance tests.
3. Install insulation materials with smooth and even surfaces. Insulate each continuous run of piping with full-length units of insulation, with single cut piece to complete run. Do not use cut pieces or scraps abutting each other. Butt insulation joints firmly to ensure complete, tight fit over all piping surfaces.

B. Fittings

1. Wrap valves, fittings, and similar items in each piping system with wicking material to ensure a continuous path (100% coverage) for the removal of condensation.
2. Cover valves, fittings, and similar items in each piping system using one of the following:
 - a. Mitered sections of insulation equivalent in thickness and composition to that installed on straight pipe runs.
 - b. PVC Fitting Covers insulated with material equal in thickness and composition to adjoining insulation.
3. Seal all fitting joints with contractor supplied VaporWick Sealing Tape or approved vapor retarder mastic compound.

C. Penetrations

Extend piping without interruption through walls, floors and similar piping penetrations.

3.4 SEAMS:

- A. On exposed insulation, all longitudinal seams shall be kept at the top and back of the pipe and circumferential joints shall be kept to a minimum. Raw end of insulation shall be concealed by neatly folding the ends of the jackets. Fittings, valve bodies and flanges shall be furnished with the same jacket materials used on adjoining insulation.

3.5 PRIOR TESTING:

- A. Covering shall not be applied until all parts of the work have been tested by the Contractor and reviewed by the Engineer.

3.6 VAPOR BARRIER:

- A. Vapor barrier shall be applied in accordance with the manufacturer's instructions to maintain the integrity of the vapor barrier on cold systems.

**WASHINGTON MIDDLE SCHOOL
BOILER REPLACEMENT
1225 N BROAD STREET, MERIDEN CT 06450**

- B. An approved vapor retarder mastic compatible with PVC must be applied between pipe insulation and fitting cover, and on fitting cover and throat overlap seam.
- C. For fittings where operating temperature is below 45 deg. For where pipe insulation thickness is greater than 1 ½”, two or more layers of Hi-Lo temp insulation inserts shall be installed beneath fitting cover.

3.7 METAL SHIELDS:

- A. Metal shields, 16 gauge galvanized, shall be applied between hangers or supports and the pipe insulation. Shields shall be roll formed to fit the insulation and shall extend up to the center line of the pipe and the length specified for the insert. Insulation shall be rigid type for length of shield to prevent crushing.

3.8 FIELD QUALITY ASSURANCE

- A. Upon completion of all insulation work covered by this specification, visually inspect the work and verify that it has been correctly installed. This may be done while work is in progress, to assure compliance with requirements herein to cover and protect insulation materials during installation.
- B. Replace any ceiling damage caused by condensation due to improper covering and sealing during the guarantee period of this job.

3.9 PROTECTION

- A. Replace damaged, removed or disturbed insulation with appropriate fiberglass insulation.
- B. The insulation contractor shall advise the general and/or the mechanical contractor as to requirements for protection of the insulation work during the remainder of the construction period, to avoid damage and deterioration of the finished insulation work.

3.10 SAFETY PRECAUTIONS

- A. Insulation contractor's employees shall be properly protected during installation of all insulation. Protection shall include proper attire when handling and applying insulation materials, and shall include (but not be limited to) disposable dust respirators, gloves, hard hats, and eye protection.
- B. The insulation contractor shall conduct all job site operations in compliance with applicable provisions of the Occupational Safety and Health Act, as well as with all state and/or local safety and health codes and regulations that may apply to the work.

END OF SECTION 22 07 00

PART 1 - GENERAL

1.1 RELATED DOCUMENTS:

- A. The General Provisions of the Contract, including General and Supplementary Conditions and Division 1, General Requirements, apply to the work specified in this Section.
- B. The General Requirements in Section 200050 shall also govern the work under this Section.

1.2 SECTION INCLUDES:

- A. Vibration isolation and seismic restraints for all mechanical and electrical system including equipment, piping, conduit and ductwork within the building.
- B. The work of this section includes but is not limited to the following:
 - 1. Vibration isolation elements.
 - 2. Equipment isolation bases.
 - 3. Piping flexible connections.
 - 4. Seismic restraints for isolated and non-isolated mechanical and electrical items.

1.3 REFERENCES:

- A. 2022 State of Connecticut Building Code.
- B. SMACNA - Seismic Restraint Manual Guidelines for Mechanical Systems.
- C. Mason Industries, Inc. Seismic Restraint Guidelines

1.4 QUALIFICATIONS:

- A. Qualifications: Only firms having five years experience designing and manufacturing seismic devices shall be capable of work in this specification.

1.5 SUBMITTALS:

- A. Submit under provisions of Section 200050.
- B. The submittal material shall include copies of descriptive data for all products and materials including but not limited to the following:
 - 1. Descriptive Data:
 - a. Catalog cuts and data sheets.

**WASHINGTON MIDDLE SCHOOL
BOILER REPLACEMENT
1225 N BROAD STREET, MERIDEN CT 06450**

- b. An itemized list showing the items to be isolated and/or seismically restrained, product type or model number to be used and loading and deflection data.
- c. Seismic restraint calculations.
- d. (Structural or civil engineer's State of Connecticut professional engineer's seal verifying design and calculations for seismic restraining system used.)

2. Shop Drawings:

- a. Drawings showing equipment base construction for each machine, including dimensions, structural member sizes, and support point locations.
- b. Drawings showing methods of suspension, support guides for conduit, piping and ductwork.
- c. Drawings showing methods for isolation of conduits, pipes and ductwork penetrating walls and floor slabs.
- d. Concrete and steel details for bases including anchor bolt locations.
- e. Number location of seismic restraints and anchors for each piece of equipment.
- f. Specific details of restraints including anchor bolts for mounting and maximum loading at each location, for each piece of equipment and/or pipe and duct locations.

1.6 GENERAL (MANUFACTURER) RESPONSIBILITIES:

A. Contractor shall have the following responsibilities:

- 1. Determine vibration isolation and seismic restraint sizes and locations per specifications.
- 2. Provide and install isolation systems and seismic restraints as scheduled or specified.
- 3. Guarantee specified isolation system deflection.
- 4. Provide installation instructions, drawings and field supervision to assure proper installation and performance.
- 5. Substitution of "Internally Isolated" mechanical equipment in lieu of the specified isolation of this section may be acceptable provided that all specified deflections and stamped seismic calculations are supplied by the equipment manufacturer.

1.7 PROJECT RECORD DOCUMENTS:

- A. Submit under provisions of Section 200050.
- B. Record actual locations and installation of vibration isolators and seismic restraints including attachment points.

**WASHINGTON MIDDLE SCHOOL
BOILER REPLACEMENT
1225 N BROAD STREET, MERIDEN CT 06450**

PART 2 - PRODUCTS

2.1 MANUFACTURERS:

- A. Mason Industries Inc. models listed below.
- B. Other approved manufacturers providing equivalent products include:
 - 1. Vibration Eliminator Co.
 - 2. Amber/Booth Co.

2.2 SEISMIC RESTRAINT TYPES:

- A. General: Installations shall be designed to safely accept external forces of one-half "G" load in any direction for all rigidly supported equipment without failure and permanent displacement of the equipment. Life safety equipment such as (fire pumps, sprinkler piping and emergency generators) shall be capable of safely accepting external forces up to one "G" load in any direction without permanent displacement of the supported equipment. Seismic restraints shall not short circuit vibration isolation systems or transmit objectionable vibration or noise.
- B. Type I (spring mount): Shall comply with general characteristics of spring isolators having a minimum o.d. to o.h. of .8 to 1 and minimum runout of 50% to solid. Shall incorporate snubbing restraint in all directions. Shall be capable of supporting equipment at a fixed elevation during equipment erection. Cast housings shall be ductile iron or aluminum. System to be field bolted or welded to deck with 1 G acceleration capability. Mason Type SSLFH or as approved.
- C. Type II (snubber): Each corner of side shall incorporate a seismic restraint having a minimum 5/8" thick resilient pad limit stops working in all directions. Restraints shall be made of plate, structural members, or square metal tubing concentric within a welded assembly incorporated resilient pads. Angle bumpers are not acceptable. System to be field bolted or welded to a deck with 1 G acceleration capability. Mason Type Z-1011 and Z-1225.
- D. Type III (cable braces): Metal cable type with approved end fastening devices to equipment and structure. System to be field bolted to deck or overhead structural members using two sided beam clamps to steel or appropriately designed insert for concrete. All parts of system including cables, clamps, excluding fastenings are to be single vendor furnished to assure seismic compliance. Mason Type SCB.
- E. Type IV (neoprene mount): Double deflection neoprene isolator encased in ductile iron or steel casing minimum .30 static deflection. System to be field bolted or welded to deck with 1 G acceleration capacity. Mason Type BR, RBA.
- F. Type V: Non-isolated equipment to be field bolted or welded (powder shots not acceptable) to resist seismic forces unless under 100 lb. Shear force required. Mason Type SAS, SAB.

2.3 VIBRATION ISOLATION – GENERAL:

- A. Vibration Isolation shall control excessive noise and vibration in the building due to the operation of machinery or equipment, and/or due to interconnected piping, ductwork, or conduit. (The installation of all vibration isolation units, and associated hangers and bases, shall be under the direct supervision of the vibration isolation manufacturer's representative.)
- B. All vibration isolators shall have either known non-deflected heights or calibration markings so that, after adjustment, when carrying their load, the deflection can be verified.
- C. All isolators shall operate in the linear portion of their load versus deflection curve. Load versus deflection curves shall be furnished by the manufacturer and must be linear over a deflection range of not less than 50% above the design deflection.
- D. The theoretical vertical natural frequency for each support point, based upon load per isolator and isolator stiffness, shall not differ from the design objectives for the equipment as a whole by more than +/- 10%.
- E. All neoprene mountings shall have a Shore hardness of 30 to 60 +/- 5, after minimum aging of 20 days or corresponding oven aging.

2.4 VIBRATION ISOLATOR TYPES:

- A. Type A: Spring isolators:
 - 1. Minimum diameter of 0.8 of the loaded operating height.
 - 2. Corrosion resistance where exposed to corrosive environment with:
 - a. Springs cadmium plated or electro-galvanized.
 - b. Hardware cadmium plated.
 - c. All other metal parts hot-dip galvanized.
 - 3. Reserve deflection (from loaded to solid height) of 50% of rated deflection.
 - 4. Minimum 1/4" thick neoprene acoustical base pad on underside, unless designated otherwise.
 - 5. Designed and installed so that ends of springs remain parallel and all springs installed with adjustment bolts.
 - 6. Non-resonant with equipment forcing frequencies or support structure natural frequencies.
 - 7. Mason Type SLF.

**WASHINGTON MIDDLE SCHOOL
BOILER REPLACEMENT
1225 N BROAD STREET, MERIDEN CT 06450**

8. When used in conjunction with seismic bracing, seismic restraint Type II shall be installed.
- B. Type B: Spring isolators shall be same as Type A, except:
1. Provide built-in vertical limit stops with minimum ¼” clearance under normal operation.
 2. Tapped holes in top plate for bolting to equipment when subject to wind load.
 3. Capable of supporting equipment at a fixed elevation during equipment erection. Installed and operating heights shall be identical.
 4. Adjustable and removable spring pack with separate neoprene pad isolation.
 5. Capable of accepting 1 G of acceleration.
 6. Mason Type SLR.
- C. Type C: Spring hanger rod isolators:
1. Spring element seated on a steel washer within a neoprene cup incorporating a rod isolation bushing.
 2. Steel retainer box encasing the spring and neoprene cut.
 3. When used in conjunction with seismic bracing, seismic restraint Type III shall be installed.
 4. Mason Type HS.
- D. Type D: Seismic Restraint, Type IV: Double deflection neoprene isolator encased in ductile iron or steel casing minimum .30 static deflection. System to be field bolted or welded to deck with 1 G acceleration capacity. Mason Type BR, RBA.
- E. Type E: Elastomer hanger rod isolators:
1. Molded unit type neoprene element with projecting bushing lining rod clearance hole.
 2. Neoprene element to be minimum 1-3/4” thick.
 3. Steel retainer box encasing neoprene mounting.
 4. Clearance between mounting hanger rod and neoprene bushing shall be minimum of 1/8”.
 5. Minimum static deflection of 0.35”.
 6. When used in conjunction with seismic bracing, seismic restraint Type III shall be installed.
 7. Mason Type HD.

**WASHINGTON MIDDLE SCHOOL
BOILER REPLACEMENT
1225 N BROAD STREET, MERIDEN CT 06450**

- F. Type F: Combination spring/elastomer hanger rod isolators:
 - 1. Spring and neoprene isolator elements in a steel box retainer. Neoprene double deflection type. Single deflection is unacceptable. Spring seated in a neoprene cup with extended rod bushing.
 - 2. Characteristics of spring and neoprene as described in Type A and Type E isolators.
 - 3. When used in conjunction with seismic bracing, seismic restraint Type III shall be installed.
 - 4. Mason Type DNHS.

- G. Type G: Pad type elastomer mountings:
 - 1. 3/4" Minimum thickness.
 - 2. 50 PSI maximum loading.
 - 3. Waffled design.
 - 4. Deflection per pad thickness.
 - 5. Galvanized steel plate between multiple layers or pad thickness.
 - 6. Suitable bearing plate to distribute load.
 - 7. Mason Type Super W.

- H. Type H: Grommet type elastomer bushings:
 - 1. One piece molded bridge bearing neoprene.
 - 2. Washer / bushing shall surround the anchor bolt.
 - 3. Flat washer face to avoid metal to metal contact.
 - 4. Mason Type HG.

- I. Type K: Pipe Anchors: All-directional acoustical pipe anchor consisting of a telescopic arrangement of two sizes of steel tubing separated by a minimum one-half inch thickness of heavy-duty neoprene and duck or neoprene isolation material. Vertical restraints shall be provided by similar material arranged to prevent vertical travel in either direction. Allowable loads on the isolation material travel in either direction. Allowable loads on the isolation material shall not exceed 500 psi and the design shall be balanced for equal resistance in any direction. Isolation to be bolted or welded depending on structure. Mason Type ADA.

2.5 EQUIPMENT BASES:

- A. Integral Structural Steel Base, Type B-1:
 - 1. Reinforced as required to prevent base flexure at start-up and misalignment of drive and driven units. Centrifugal fan bases complete with motor slide rails.
 - 2. Drills for drive and driven unit mounting template.
 - 3. Must be utilized with seismic restraint Type I, II, or IV.

**WASHINGTON MIDDLE SCHOOL
BOILER REPLACEMENT
1225 N BROAD STREET, MERIDEN CT 06450**

4. Mason Type M, WFB.
- B. Concrete Inertia Base, Type B-2:
1. Vibration isolator manufacturer shall furnish rectangular structural concrete forms for floating foundation. Bases for split case pumps shall be large enough to provide support for suction and discharge base ells. The base depth shall be a minimum of 1/10 of the longest span but not less than 6" or greater than 14".

Forms shall include minimum concrete reinforcement consisting of ½" bars or angles in place in 6" centers running ways and a layer 1 ½" above the bottom and a top layer of reinforcing steel as above for all bases exceeding 120" in one direction. Isolators shall be set into pocket housings which are an integral part of the base construction and set at the proper height to maintain a 1" clearance below the base. Bases shall be furnished with templates and anchor bolt sleeves as part of this system.
 2. Must be utilized with seismic restraint Type I, II or IV.
 3. Mason Type K, BMK.
- C. Isolated Curb, Type B-3:
1. Curb mounted rooftop equipment shall be mounted on structural spring isolation curbs that directly sit on roof construction and are flashed and waterproofed into roof's membrane waterproofing system. Manufacturer's curb shall not be used.
 2. All spring locations shall have removable waterproof covers to allow for spring adjustment and/or removal. All curbs shall be pitched. Contractor shall coordinate required pitch with the structural.
 3. Curbs shall have a provision for an optional sound barrier kit.
 4. All spring mounts shall be as Isolator Type A.
 5. Curbs shall have static deflection.
 6. Curbs shall be rated for 1 G of acceleration and shall be wind restrained for 110 mph wind loads.
 7. Curbs shall have California OSHPD approval.
 8. Sound barrier package, SBC-3. Two layers of waterproof sheetrock and sound insulating material shall be supplied and installed by this contractor.
 9. Curbs to be welded to building steel or bolted to concrete decks to attain acceleration criteria.

**WASHINGTON MIDDLE SCHOOL
BOILER REPLACEMENT
1225 N BROAD STREET, MERIDEN CT 06450**

10. Mason Type RSC.

- D. Roof Isolation Rail System, Type B-4: Rooftop fans, condensing units, exterior ducted air handling units, etc., shall be installed on continuous equipment support piers which shall combine a regular equipment support and an isolation system into one assembly. The system shall be designed with 2" or 3" static deflection steel springs which are both adjustable, removable, and interchangeable after equipment has been installed. The system shall maintain the same operating and installed height both with and without the equipment load and shall be fully restrained during wind load conditions allowing no more than 1/4" motion in any direction. The isolation pier shall be designed to accept the membrane waterproofing. The entire assembly shall be cold spray galvanized or plastic coated.

System design permits minimum 1 G of acceleration. Curbs to be welded to building steel or bolted to concrete decks to attain acceleration criteria. Mason Industries Model RSR.

E. Non-isolated seismic roof curbs, Type B-5:

1. Curb sections shall be either structural steel channels or 12GA. sheet metal.
2. Field assembled joints shall include a minimum of 2 rows of three bolts at each connection.
3. Curb to have a factory installed wood nailer.
4. System to be bolted or welded to deck.
5. System shall be designed for minimum 1/2G. of acceleration.
6. Mason Type RRC.

F. Dunnage steel mounted rooftop equipment. Type B-6:

1. Rooftop equipment shall be mounted on structural tubular steel boxed rail assembly.
2. Tubular steel rails shall be attached to seismic rated spring vibration isolators.
3. Isolators shall be bolted or welded to dunnage steel to meet seismic criteria of 1/2G acceleration.
4. Entire assembly shall be hot dipped galvanized.
5. Mason Type RSLR.

2.6 FLEXIBLE CONNECTORS:

A. Elastomer Type FC-1:

1. Manufactured of Kevlar reinforcement and EPDM, both molded and cured with hydraulic presses.

**WASHINGTON MIDDLE SCHOOL
BOILER REPLACEMENT
1225 N BROAD STREET, MERIDEN CT 06450**

2. Straight connectors to have two spheres reinforced with a molded-in external ductile iron ring between spheres.
 3. Elbows shall be long radius type.
 4. Rated 250 psi at 170 degrees F. Dropping in a straight line to 170 psi at 250 degrees F for sizes 1-1/2" to 12" elbows. Elbows shall be rated no less than 90% of straight connections.
 5. Sizes 10" to 12" to employ control cables with neoprene end fittings isolation from anchor plates by means of 1/2" bridge bearing neoprene bushings.
 6. Minimum safety factor, 4:1 at maximum pressure ratings.
 7. Systems bolted to victaulic type couplings or gate, butterfly, or check valves to have a minimum 5/8" flange spacer installed between conductor and coupling on flange.
 8. Submittals to include test reports.
 9. Mason Type Safeflex SFDEJ.
- B. Flexible Stainless Hose, Type FC-2:
1. Type 321 stainless steel braided flexible metal hose.
 2. 2" pipe size and smaller: threaded carbon steel fittings.
 3. 1 1/2" pipe size and larger: Class 150 carbon steel flanges.
 4. Suitable for operating pressure with 4:1 minimum safety factor.
 5. Flexible Metal Hose Company type DFC and MFC.
- C. Unbraided Exhaust Hose, Type FC-3:
1. Low pressure stainless steel annularly corrugated.
 2. Fitted with flanged ends.
 3. Maximum temperature 1,500 degrees F.
 4. Mason Type SDL-RF.
- D. 60 Degree VEE assembly:
1. Type 304 stainless steel hose and braid.
 2. 4" motion in all directions.
 3. ASA 150 carbon steel flanges.

PART 3 - EXECUTION

3.1 GENERAL SEISMIC RESTRAINT REQUIREMENTS:

- A. Install seismic restraints in accordance with manufacturers recommendations.
- B. Seismic restraining system Type III: Install taut for non-isolated equipment and slack with 1/2" cable deflection for isolated systems.
- C. Seismically restrain all piping, conduit and ductwork with Type III or Type V seismic restraint in accordance with guidelines outlined below. Restraints which are to be used in conjunction with vibration isolators shall be Type III.

**WASHINGTON MIDDLE SCHOOL
BOILER REPLACEMENT
1225 N BROAD STREET, MERIDEN CT 06450**

1. Carbon steel piping shall be braced at maximum 40' intervals and at turns of more than 4'. Lateral bracing at maximum 80' intervals. No-hub piping to be braced at maximum 20' intervals or maximum 40' using ½ G acceleration rated couplings.
 2. Ductwork shall be braced at maximum 30' and at every turn and duct run end. Lateral bracing at maximum 60'.
- D. Equipment mounted on housekeeping pads: Pads shall be properly doweled or expansion shielded to deck to meet acceleration criteria. Mason Type HPA.
- E. Seismic Restraints are not required for the following:
1. Piping in mechanical rooms or penthouses less than 1-1/4" O.D, except fire protection piping.
 2. Piping in other areas less than 2-1/2" O.D. except fire protection piping.
 3. Ducts which have a cross sectional area less than 6 square feet.
 4. All piping suspended by individual hanger 12" or less in length from the top of the pipe to the bottom of the support for the hanger, except fire protection piping.
 5. Fire protection feed mains and cross mains suspended by individual hangers 6" or less in length from the top of the pipe to the bottom of the support for the hanger.
 6. All top supported ducts suspended by hangers 12" or less in length from the top of the duct to the bottom of the support for the hanger.
 7. Electrical conduit less than 1-1/2" I.D.
- F. For overhead supported equipment, over stress of the building structure must not occur. Bracing can occur from:
1. Flanges to structural beams.
 2. Upper or lower truss chords in bar joist construction at panel points.
 3. Cast-in-place inserts or drilled and shielded inserts in concrete structures.
- G. Building seismic and expansion joints: Install hinged joints at piping crossing expansion and seismic joints and anchor the piping either side.

Anchors on each end are to be capable of accepting 1.5 times the operating pressure multiplied by the projected area of the pipe.

Fittings shall be able to compensate for 4" motions in all directions.

1. Offset shall be accomplished by the annular motion of a double sphere connector (TYPE FC-1) bolted to each end of an intermediate steel pipe. Bracket each joint with hinged steel connections. Hinge shall have a pin / slot assembly on both sides. The completed assembly shall be Mason Type Safeflex SFDEJ-HE.

3.2 GENERAL VIBRATION ISOLATION REQUIREMENTS:

- A. Install isolators in accordance with manufacturer's recommendations. Vibration isolators shall not cause any change of position resulting in stresses or misalignment.
- B. Mechanical equipment shall be isolated from the building structure by means of noise and vibration isolators.
- C. Each fan and motor assembly shall be supported on a single structural steel frame (where noted on the isolation and seismic schedule). Flexible duct connections shall be provided at inlet and discharge ducts.
- D. Provide pairs of horizontal limit springs (Thrust restraints) on fans with more than 6.0 inch static pressure, and on hanger supported, horizontally mounted axial fans where indicated
- E. Provide resiliently mounted equipment, piping, and ductwork with seismic snubbers. Each inertia base shall have minimum of four seismic snubbers located close to isolators. Snub equipment designated for post disaster use to 0.05 inch (1.5 mm) maximum clearance. Other snubbers shall have clearance between 0.15 inch (4 mm) and 0.25 inch (7mm).]
- F. Ductwork connected to rotating equipment shall be supported with Type C or Type F isolators for the first three support points.
- G. Installation of piping vibration isolators:
 - 1. All piping, except fire protection standpipe systems, is included under this section.
 - 2. Vibration isolators shall be installed on all piping outside the shafts as follows:
 - a. Piping in mechanical rooms.
 - b. Piping where exposed on roof.
 - c. Piping connected to rotating equipment and pressure reducing stations.
 - 3. Horizontal suspended pipe 2" and smaller and all steam piping shall be suspended by Type E isolator with a minimum 3/8" deflection. Water pipe larger than 2" shall be supported by Type C or Type F isolator with minimum 1" whichever is greater.
 - 4. Horizontal pipe floor supported at slab shall be supported via Type A with a minimum static deflection of 1" or same deflection as isolated equipment to which pipe connects, whichever is greater.

**WASHINGTON MIDDLE SCHOOL
BOILER REPLACEMENT
1225 N BROAD STREET, MERIDEN CT 06450**

5. Vertical riser pipe supports under 2" diameter shall utilize Type G isolation pads.
6. Vertical riser guides, if required, shall avoid direct contact of piping with building.
7. Pipe anchors or guides, where required, shall utilize resilient pipe anchors, Mason Industries Type ADA, or equivalent, to avoid direct contact of piping with building.
8. Isolated piping which requires sway bracing shall utilize two neoprene elements, Type G to accommodate tension and compression forces.
9. Pipe extension and alignment connectors: Provide connectors at riser takeoffs, cooling and heating coils, and elsewhere as required, to accommodate thermal expansion and misalignment.

H. Pipe Isolation Schedule

PIPE SIZE - INCH (MM)	ISOLATED DISTANCE FROM EQUIPMENT
1 (25)	120 diameters (3.0m)
2 (50)	90 diameters (4.5m)
3 (80)	80 diameters (6.0m)
4 (100)	75 diameters (7.5m)
6 (150)	60 diameters (9.0m)
8 (200)	60 diameters (12.0m)
10 (250)	54 diameters (13.5m)
12 (300)	50 diameters (15.0m)
16 (400)	45 diameters (18.0m)
24 (600)	38 diameters (23.0m)

3.3 EQUIPMENT INSTALLATION:

- A. Requirements for installation on concrete inertia bases shall be as follows:
1. Minimum operating clearance between concrete inertia and base and housekeeping pad or floor shall be 1".
 2. The equipment structural steel or concrete inertia base shall be placed in position and supported temporarily by blocks or shims, as appropriate, prior to the installation of the machine or isolators.
 3. The isolators shall be installed without raising the machine and frame assembly.
 4. After the entire installation is complete and under full operational load, the isolators shall be adjusted so that the load is transferred from the blocks to the isolators. When all isolators are properly adjusted, the blocks or shims shall be barely free and shall be removed.
 5. Install equipment with flexibility in wiring connection.
 6. Verify that all installed isolator and mounting systems permit equipment motion in all directions. Adjust or provide additional resilient restraints to flexibly limit start-up equipment lateral motion to ¼".

**WASHINGTON MIDDLE SCHOOL
BOILER REPLACEMENT
1225 N BROAD STREET, MERIDEN CT 06450**

7. Prior to start-up, clean out all foreign matter between bases and equipment. Verify that there are no isolation short circuits in the base, isolators, or seismic restraints.

3.4 INSPECTION:

- A. Upon completion of the installation of all vibration isolation, flexible connections and seismic restraints, the manufacturer's local representative shall visit the project job site, visibly inspect all installations and report, in writing, any and all deficiencies from the specifications. Any additional corrective measures required to put the system in total compliance shall be the responsibility of the installing contractor.

END OF SECTION 23 05 48

PART 1 - GENERAL

1.1 RELATED DOCUMENTS:

- A. The General Provisions of the Contract, including General and Supplementary Conditions and General Requirements, apply to the work specified in this Section.
- B. The General Requirements in Section 200050 shall also govern the work under this Section.
- C. Examine all drawings and data and coordinate the work of this Section with all related and adjoining work.

1.2 SCOPE OF WORK:

- A. Provide all labor, materials, equipment and tools required to complete the work described and shown on the contract drawings.

PART 2 -PRODUCTS

2.1 PRODUCTS:

- A. None required.

PART 3 - EXECUTION

3.1 GENERAL:

- A. Work shall be performed only by a firm which employs certified testing, adjusting and balancing technicians as listed by the Sheet Metal Industry National Certification Board of TAB Technicians. The work may be performed by a certified Test, Adjusting and Balancing technician who may be assisted by other TAB technicians. This firm shall provide personnel trained and experienced in system balancing. This requirement will not be waived under any condition.
- B. Before submitting system performance data for approval or acceptance, the firm shall perform all necessary tests and make all necessary adjustments as required to obtain the flow as called for on the Contract Documents.
- C. The balance reports shall include the names, signatures and registration numbers of the technicians assigned to the project. Submit reports prior to final payment.

**WASHINGTON MIDDLE SCHOOL
BOILER REPLACEMENT
1225 N BROAD STREET, MERIDEN CT 06450**

3.2 ACCEPTABLE FIRMS:

- A. Contractor shall submit the name of the proposed balancing contractor at the time of the bid. Request to employ the balancing and testing firm must be accompanied by a complete brochure of the firm listing previous installations successfully balanced, length of time in business, names and qualifications of employees and list of instruments available for use on the project.

3.3 HYDRONIC SYSTEMS:

- A. Prior to the start of balancing, the firm shall check the rotation of all pumps.
- B. The firm shall compile the following data for each pump insofar as they apply and shall include it on the final submittal:

PUMP DESCRIPTIVE DATA

Pump Number
System Served
Pump Size
Pump Make
Pump Horsepower
Motor Safety Factor
Motor Manufacturer & Size
Voltage & Phase

PUMP DESIGN & DELIVERED CONDITIONS

Pump Rpm
Pump Inlet & Outlet Pressure
Amperage
Brake Horsepower
Gpm Supply

SYSTEM DESIGN & DELIVERED CONDITIONS

Flow (Gpm) through each pump
Inlet & Outlet temperature at 3-way valve
Flow (Gpm) through each coil
Inlet & Outlet Pressure at each coil
Inlet & Outlet temperature at each coil
Type of instrument and method used

3.4 INSTALLATION TOLERANCES:

- A. Adjust heating system to the following tolerances:
1. Supply water temperature 80 degree F to 120 deg. F 0% to +10% of design value.
 2. Supply water temperature 120 degree F to 160 deg. F -5% to +10% of design value.
 3. Supply water temperature above 160 degree F -10% to +10% of design value.

3.5 FIELD VERIFICATION:

- A. The design Engineer may request verification of data contained in the balancing report. If requested the TAB technician whose initials appear on the data sheets shall take outlet and inlet readings selected at random by the Engineer who will compare these readings to those in the submitted report. If the field verification is not satisfactory, the firm doing the TAB work shall completely rebalance the system and a new report shall be prepared and submitted for approval.

END OF SECTION 23 05 93

PART 1 - GENERAL

1.1 RELATED DOCUMENTS:

- A. The General Provisions of the Contract, including General and Supplementary Conditions and Division 1, General requirements, apply to the work specified in this Section.
- B. The General Requirements in Section 200050 shall also govern the work under this Section.
- C. Scope of Work: This Section contains details for the insulation of pipe, ductwork and equipment installed under Division 23.

1.2 SUBMITTALS:

- A. In accordance with Section 200050, the following items shall be submitted for approval.
 - Piping insulation
 - Fitting insulation
 - Equipment insulation

1.3 MECHANICAL SYSTEMS INSULATION:

- A. Furnish and install all thermal and protective insulation as specified herein for piping, and equipment as shown on the drawings.
- B. The following mechanical items shall be insulated:
 - Piping - hot water supply and return
 - Fittings - Valve bodies, Victaulic couplings, elbows, tees, etc.
 - Equipment insulation

1.4 SYSTEM PERFORMANCE

- A. Insulation materials furnished and installed hereunder should meet the minimum thickness requirements of ASHRAE 90.1 (2013), "Energy Efficient Design of New Buildings," of the American Society of Heating, Refrigeration, and Air Conditioning Engineers. However, if other factors such as condensation control or personnel protection are to be considered, the selection of the thickness of insulation should satisfy the controlling factor.
- B. Insulation materials furnished and installed hereunder shall comply with NFPA 255 and shall have a maximum flame spread index of 25 and a maximum smoke developed index of 50 when tested in accordance with the following testing standard:
 - Underwriters' Laboratories, Inc. UL 723
 - Adhesives used for applying the sealed jackets shall also conform to these same ratings. The use of wheat paste or any other material not meeting these requirements will not be allowed.

**WASHINGTON MIDDLE SCHOOL
BOILER REPLACEMENT
1225 N BROAD STREET, MERIDEN CT 06450**

1.5 QUALITY ASSURANCE

- A. Insulation materials and accessories furnished and installed hereunder shall, where required, be accompanied by manufacturers' current submittal or data sheets showing compliance with applicable specifications.
- B. Insulation materials and accessories shall be installed in a workmanlike manner by skilled and experienced workers who are regularly engaged in commercial insulation work.
- C. All covering and insulating materials shall be manufactured by Owens-Corning, Knauf, Johns Manville or Armstrong.

1.6 SEAMS:

- A. On exposed insulation, all longitudinal seams shall be kept at the top and back of the pipe and circumferential joints shall be kept to a minimum. Raw end of insulation shall be concealed by neatly folding the ends of the jackets. Fittings, valve bodies and flanges shall be furnished with the same jacket materials used on adjoining insulation.

1.7 PRIOR TESTING:

- A. Covering shall not be applied until all parts of the work have been tested by the Contractor and reviewed by the Engineer.

1.8 VAPOR BARRIER:

- A. Vapor barrier shall be applied in accordance with the manufacturer's instructions to maintain the integrity of the vapor barrier on cold systems.
- B. An approved vapor retarder mastic compatible with PVC must be applied between pipe insulation and fitting cover, and on fitting cover and throat overlap seam.
- C. For fittings where operating temperature is below 45 deg. For where pipe insulation thickness is greater than 1 ½", two or more layers of Hi-Lo temp insulation inserts shall be installed beneath fitting cover.

1.9 METAL SHIELDS:

- A. Metal shields, 16 gauge galvanized, shall be applied between hangers or supports and the pipe insulation. Shields shall be roll formed to fit the insulation and shall extend up to the center line of the pipe and the length specified for the insert. Insulation shall be rigid type for length of shield to prevent crushing.

1.10 DELIVERY AND STORAGE OF MATERIALS

- A. All of the insulation materials and accessories covered by this specification shall be delivered to the job site and stored in a safe, dry place with appropriate labels and/or other product identification.

**WASHINGTON MIDDLE SCHOOL
BOILER REPLACEMENT
1225 N BROAD STREET, MERIDEN CT 06450**

- B. The contractor shall use whatever means are necessary to protect the insulation materials and accessories (wick material, sealing tape, etc) before, during, and after installation. No insulation material shall be installed that has become damaged in any way. The contractor shall also use all means necessary to protect work and materials installed by other trades.

PART 2 - PRODUCTS

2.1 PIPING:

- A. Insulate all new domestic hot, cold and recirculating hot water lines with Johns Manville Fiberglass ASJ with S.S.L. II, pipe insulation with double self-sealing lap having a factory applied jacket. All horizontal and vertical insulated piping located below 8'-0" AFF level and not protected with enclosures shall be protected with Zeston 2000 P.V.C. 30 Mil jacketing. Outdoor, exposed piping shall be protected with aluminum jacket. All horizontal and vertical insulated pipes located in the Boiler Room shall be protected with color coded Zeston 300 Series 30 Mil jacket. Acceptable equals are by SpeedLine or Proto.
- B. All piping shall be covered as follows: Apply insulation to clean dry pipe with side and end joints butted tightly. Seal lap of jacket and butt joint strips with Benjamin Foster 82-07 vapor barrier lap adhesive.

Insulate fittings, flanges and valves of piping with mitered pipe insulation, or F/G premolded fittings made smooth with insulating cement and jacket with glass cloth saturated with Benjamin Foster 30-60 lagging adhesive. Vinyl or plastic fitting jackets will be allowed.

- C. Insulate chilled water, condensate piping the same as for hot piping above except vapor seal all joints, seams, elbows and fittings.
- D. Foam insulation:
1. Piping and Fittings. MicroLok plain pipe insulation shall be wired or taped in place over clean, dry pipe with all joints butted firmly together. Vapor retarder shall be Micro-Lok AP-T plus.
 2. The insulation shall be finished with metal jacketing with a laminated moisture retarder. Metal jacketing shall be overlapped 2 to 3 inches (51 to 76 mm) and held in place with sheet metal screws or metal bands.
 3. Elbows and tees shall be finished with matching metal fitting covers. Other fittings in metal-jacketed systems shall be finished with conventional weather-resistant insulating materials with painted aluminum finish.

**WASHINGTON MIDDLE SCHOOL
BOILER REPLACEMENT
1225 N BROAD STREET, MERIDEN CT 06450**

- E. Provide minimum insulation thickness in accordance with the following table.
Minimum Pipe Insulation

Piping System Types	Fluid Temp. Range	Runouts 2 in +	1 in. and less	1-1/4 to 2 in.	2-1/2 to 4 in.	5 and Larger
	F	in.	in.	in.	in.	in.
Heating Systems						
Hot Water						
Low Temp	120-200	0.5	1.0	1.0	1.5	1.5

2.2 FITTING COVERS:

- A. Fitting covers may be used in lieu of insulating cement and jacket. Provide fitting covers in Zeston - 2000 P.V.C. (20 Mil thickness) by Johns Manville. Provide color coded fitting covers in Zeston 300 Series 30 Mil jacket for fittings located in the Boiler Rooms. Acceptable substitutions are by SpeedLine or Proto.
- B. General - The matching insert (fiberglass) should either be wrapped completely around the fitting or snugly positioned inside the fitting for proper fit. The insert shall cover the full inner surface area of the fitting cover. The fitting cover is then to be applied over the fitting and insert, and the throat secured by either tack fastening, taping, or banding.
- C. Cold Pipe - Fitting systems below ambient temperature must have a continuous vapor barrier, either with pressure sensitive PVC Tape, or an approved adhesive system. When PVC Tape is used, a 2" downward lap is required. On cold lines in severe ambient temperatures, the fiberglass insert shall be the same thickness as the adjacent pipe insulation. All joints shall then be sealed with PVC Tape.

2.3 COMBUSTION AIR PIPE:

- A. Insulate combustion air pipe in Mechanical Room with 1" thick, R-5, fiberglass ASJ-25 equipment insulation.
- B. Insulation shall be cut to fit the shape and contour of the equipment. All voids between pipe surface and insulation shall be packed with light density fiberglass. Impale insulation over welded pins on 12" centers and secure in place with speed washers.
- C. The insulation shall be vapor sealed to provide a complete airtight envelope. Vapor barrier shall consist of one layer of Ludlow Foil Barrier Paper smoothly adhered to the insulation or cement surface with Benjamin Foster 82-07 Vapor Barrier Lap Adhesive.

PART 3 – EXECUTION

3.1 SITE INSPECTION

- A. Before starting work under this section, carefully inspect the site and installed work of other trades and verify that such work is complete to the point where installation of materials and accessories under this section can begin.
- B. Verify that all materials and accessories can be installed in accordance with project drawings and specifications and material manufacturer's recommendations.
- C. Verify, by inspecting product labeling, submittal data, and/or certifications which may accompany the shipments, that all materials and accessories to be installed on the project comply with applicable specifications and standards and meet specified thermal and physical properties.

3.2 PREPARATION

- A. Ensure that insulation is clean, dry, and in good mechanical condition and that all factory-applied facings are intact and undamaged. Wet, dirty, or damaged insulation is not acceptable for installation.
- B. Ensure that pressure testing of piping and fittings has been completed prior to installing insulation.

3.3 INSTALLATION

- A. General
 - 1. Install all insulation materials and accessories in accordance with manufacturer's published instructions and recognized industry practices to ensure that it will serve its intended purpose.
 - 2. Install insulation on piping subsequent to painting, and acceptance tests.
 - 3. Install insulation materials with smooth and even surfaces. Insulate each continuous run of piping with full-length units of insulation, with single cut piece to complete run. Do not use cut pieces or scraps abutting each other. Butt insulation joints firmly to ensure complete, tight fit over all piping surfaces.
- B. Fittings
 - 1. Wrap valves, fittings, and similar items in each piping system with wicking material to ensure a continuous path (100% coverage) for the removal of condensation.
 - 2. Cover valves, fittings, and similar items in each piping system using one of the following:

**WASHINGTON MIDDLE SCHOOL
BOILER REPLACEMENT
1225 N BROAD STREET, MERIDEN CT 06450**

- a. Mitered sections of insulation equivalent in thickness and composition to that installed on straight pipe runs.
 - b. PVC Fitting Covers insulated with material equal in thickness and composition to adjoining insulation.
3. Seal all fitting joints with contractor supplied VaporWick Sealing Tape or approved vapor retarder mastic compound.
- C. Penetrations
- Extend piping insulation without interruption through walls, floors and similar piping penetrations.

3.4 FIELD QUALITY ASSURANCE

- A. Upon completion of all insulation work covered by this specification, visually inspect the work and verify that it has been correctly installed. This may be done while work is in progress, to assure compliance with requirements herein to cover and protect insulation materials during installation.

3.5 PROTECTION

- A. Replace damaged, removed or disturbed insulation with appropriate fiberglass insulation.
- B. The insulation contractor shall advise the general and/or the mechanical contractor as to requirements for protection of the insulation work during the remainder of the construction period, to avoid damage and deterioration of the finished insulation work.

3.6 SAFETY PRECAUTIONS

- A. Insulation contractor's employees shall be properly protected during installation of all insulation. Protection shall include proper attire when handling and applying insulation materials, and shall include (but not be limited to) disposable dust respirators, gloves, hard hats, and eye protection.
- B. The insulation contractor shall conduct all job site operations in compliance with applicable provisions of the Occupational Safety and Health Act, as well as with all state and/or local safety and health codes and regulations that may apply to the work.

END OF SECTION 23 07 00

PART 1 - GENERAL

1.1 RELATED DOCUMENTS

- A. The General Provisions of the Contract, including General and Supplementary Conditions and General Requirements, apply to the work specified in this Section.
- B. The General Requirements in Sections 200050 shall also govern the work under this Section.
- C. Examine all drawings and data and coordinate the work of the Section with all related and adjoining work.

1.2 GENERAL REQUIREMENTS

Description – **This specification for a Building Automation System (BAS) as detailed herein shall be strictly enforced.** Provide a Building Automation System (BAS) incorporating LonMark certified LONWORKS devices communicating over a Local Operating Network (LON) or BACnet Testing Laboratories (BTL) certified BACnet devices communicating over a Master-Slave Token Passing (MSTP) network at the field level and Niagara4 based network managers at the network level. The Niagara 4 based network managers shall bridge the Lonworks and/or BACnet/MSTP field communications network to the Meriden Public Schools Local and/or Wide Area Network, as designated by the Meriden Public Schools, and shall communicate seamlessly with the other Niagara 4 based devices on the Meriden Public Schools enterprise-wide BAS network. The BAS shall consist of Direct Digital Control (DDC) controllers, Building Controllers (BC), network management tools, programming tools, web browser based Graphical User Interface, sensors, relays, valves, actuators, and other equipment as may be necessary to provide for a complete and operational control system for the HVAC and other building related systems as described within these specifications.

The system installed shall seamlessly connect devices other than HVAC throughout the building regardless of subsystem type, i.e. HVAC, lighting, and power systems devices should easily coexists on the same network channel without the need for gateways. LONWORKS or BACnet components not supplied by the primary manufacturer of the BAS shall be integrated to share common software for network communications, time scheduling, alarm handling, and history logging.

The documentation contained in this section and other contract documents pertaining to HVAC Controls is schematic in nature. The Contractor shall provide hardware and software necessary to implement the functions shown or as implied in the contract documents.

**WASHINGTON MIDDLE SCHOOL
BOILER REPLACEMENT
1225 N BROAD STREET, MERIDEN CT 06450**

System configuration and monitoring shall be performed via a PC-type computer. Under no circumstances shall the PC be used as a control device for the network. It can be used for storage of data.

Open Systems Design - It is the Meriden Public Schools expressed goal to expand/extend the existing Niagara4 platform currently installed and to have all buildings under the responsibility of the MBOE to be fully configured, programmed and functional through the existing Campus Wide Supervisory Server. The BAS provided shall maintain open interoperability in the following areas.

Communications - Provide a peer-to-peer networked, stand-alone, distributed control system with the capability to integrate ANSI/ASHRAE Standard 135-2001 BACnet, LONWORKS technology, MODBUS, OPC, and other open communication protocols in one open, interoperable system. Where existing systems using proprietary protocols exist, a gateway or driver may be incorporated to provide for interoperability.

Network Management - Network management tools shall be based upon Niagara Framework technology as developed by the Tridium Corporation. All tools and hardware provided shall comply with the current release of the Niagara Framework platform.

User Access - The supplied system must incorporate the ability to access all data using standard Web browsers without requiring a proprietary operator/user interface and configuration programs.

Databases - All controller program graphics and network databases shall be provided in a Niagara Framework 4 format. The database shall be stored on the existing Meriden Public Schools server and provided on a separate memory device upon final acceptance of the project. An updated database shall be provided on a memory device at the end of the warranty period.

Building Controllers (BC) - All BCs (devices that provide for communication between the field level controllers and the Meriden Public Schools wide and/or local area network, and manage facility global functions such as alarms, trends, schedules and normalization of data) shall conform to the current release of the Niagara 4 Framework. All BCs shall be furnished with extended memory. No BC shall be provided with less than 128 MB of RAM. The number of BACnet or Lonworks nodes (controllers) attached to any Niagara4 based network manager shall not exceed the following limits:

**WASHINGTON MIDDLE SCHOOL
BOILER REPLACEMENT
1225 N BROAD STREET, MERIDEN CT 06450**

COMBINED MEMORY	MAXIMUM NUMBER OF NODES
128 MB SDRAM/64 MB SERIAL FLASH	15
256 MB DDR RAM/128 MB SERIAL FLASH	50
1 GB DDR2 RAM/1 GB SERIAL FLASH	125

Regardless of the maximum number of nodes indicated above, it is ultimately the exclusive responsibility of the systems integrator/building controls contractor to ensure that the BC has adequate resources for the number of nodes (controllers) attached to it.

All Niagara 4 Network Manager controllers (BC) shall be integrated into the existing MBOE Campus Wide Supervisory Server. All local control programming shall reside on the network managers to maintain standalone control and all system wide programming and all graphical images shall be hosted and served by the supervisory server. The Meriden Public Schools will supply all required static IP address' as necessary to accommodate multiple BC's per building.

Direct Digital Controllers (DDC) - All DDC devices for HVAC and lighting control, with the exception of DDC device furnished as part of the OEM control package, shall be certified to the current LONMARK and BTL standards appropriate to their application provided an appropriate LONMARK or BTL Certification standard exist. All points within a controller including hard I/O and software based points shall be available for viewing, management, and manipulation through the Niagara Framework tools.

Software Tools - All software tools needed for full functional use, including programming of BCs and DDC, network management and expansion, and graphical user interface development, of the BAS described within these specifications, shall be provided to the Meriden Public Schools or his designated agent. Any licensing required by the manufacturer now and into the future, including changes to the licensee of the software tools and the addition of hardware corresponding to the licenses, to allow for a complete and operational system for both normal day to day operation and servicing shall be provided. Any such changes to the designated license holders shall be made by the manufacturer upon written request by the Meriden Public Schools or his agent. Any cost associated with the license changes shall be identified within the BAS submittals.

Programming Tools - Provide freely available Niagara 4 Wizards to facilitate the programming and configuration of all of the DDC devices that are provided for the HVAC and lighting control. Wizards shall be provided free of charge and be compatible with the current published versions of the network management tool

**WASHINGTON MIDDLE SCHOOL
BOILER REPLACEMENT
1225 N BROAD STREET, MERIDEN CT 06450**

that is provided as part of this project. The wizard software shall be available for public access from the manufacturer’s web site. These wizard programming tools shall be compatible with at least 3 other brands of the Niagara Framework network management tools. The SI shall demonstrate as part of their prequalification as to how they intend to comply with these requirements.

Software License Agreement - The Meriden Public Schools shall sign a copy of the manufacturer's standard software and firmware licensing agreement as a condition of this contract. Such license shall grant use of all programs and application software to Meriden Public Schools as defined by the manufacturer's license agreement, but shall protect manufacturer's rights as it relates to disclosure of trade secrets contained within said software. The Meriden Public

Schools shall be the named license holder of all software associated with any and all incremental work on the project(s). In addition, the Meriden Public Schools shall receive ownership of all job specific configuration documentation, data files, and application-level software developed for the project. This shall include all custom, job specific software code, databases and documentation for all configuration and programming that is generated for a given project and/or configured for use with the BC, BAS Server(s), and any related LAN / WAN / Intranet and Internet connected routers and devices. Any and all required IDs and passwords for access to any component or software program shall be provided to the Meriden Public Schools.

The System Integrator shall provide as part of the submittals a copy of the Niagara Compatibility Statement (NiCS) verifying that all aspect of the Niagara Framework as provided maintain an Open System Design. The System as provided shall confirm with the following NiCS

Property	Value
STATION COMPATIBILITY IN	All
STATION COMPATIBILITY OUT	All
TOOL COMPATIBILITY IN	All
TOOL COMPATIBILITY OUT	All

Quality Assurance

General - The HVAC Control System shall be furnished, engineered, and installed by a licensed Controls Contractor or System Integrator (SI). All work provided under this section shall be provided by direct employees of the SI or under the direct supervision of the SI personnel.

**WASHINGTON MIDDLE SCHOOL
BOILER REPLACEMENT
1225 N BROAD STREET, MERIDEN CT 06450**

System Integrator Qualifications

The SI must be regularly engaged in the service and installation of LONWORKS, BACnet, and Niagara based systems as specified herein, The SI shall have a minimum of 5 years experience in the sales, installation, engineering, programming servicing and commissioning of the Niagara platform and the field controllers as proposed

The system integrator must be an authorized factory direct representative in good standing of the manufacturer of the proposed hardware and software components. Provide a letter dated within the last 6 months, from the manufacture certifying that the System Integrator is an authorized factory direct representative.

The SI shall have an office within 20 miles of the Building site that is staffed with a minimum of five (5) technicians who have successfully completed the factory authorized training of the proposed manufactures hardware and software components and have successfully completed a Niagara 4 certification course. SI must provide proof of required training. The SI capabilities shall include engineering and design of control systems, programming, electrical installation of control systems, troubleshooting shooting and service.

The SI shall submit a list of no less than three (3) similar projects, which have similar Building Automation Systems as specified herein installed by the SI. These projects must be on-line and functional such that the Meriden Public Schools representative can observe the system in full operation.

Hardware and Software Component Manufacturer Qualifications

The manufacturer of the hardware and software components must be primarily engaged in the manufacture of both LonWorks and BACnet based systems as specified herein, and must have been so for a minimum of three (3) years. The manufacturer shall demonstrate that they are the manufacturer of all DDC devices and Niagara 4 products provided.

The manufacturer of the hardware and software components as well as its subsidiaries must be a member in good standing of the LONMARK Association, BACnet International, and the BACnet Manufacturers Association.

The manufacturer of the hardware and software components shall have a technical support group accessible via a toll free number that is staffed with qualified personnel, capable of providing instruction and technical support service for networked control systems.

Submittals

Submit 6 complete sets of documentation in the following phased delivery schedule:

1. Valve and damper schedules
2. Equipment data cut sheets
3. System schematics, including:
 - a. sequence of operations
 - b. point names

**WASHINGTON MIDDLE SCHOOL
BOILER REPLACEMENT
1225 N BROAD STREET, MERIDEN CT 06450**

- c. point addresses
 - d. point to point wiring
 - e. interface wiring diagrams
 - f. panel layouts
 - g. system riser diagrams
4. Visio or AutoCAD compatible as-built drawings

Upon project completion, submit operation and maintenance manuals, consisting of the following:

1. Index sheet, listing contents in alphabetical order
2. Manufacturer's equipment parts list of all functional components of the system, disk of system schematics, including wiring diagrams
3. Description of sequence of operations
4. As-Built interconnection wiring diagrams
5. User's documentation containing product, system architectural and programming information.
6. Trunk cable schematic showing remote electronic panel locations, and all trunk data
7. List of connected data points, including panels to which they are connected and input device (ionization detector, sensors, etc.)
8. Copy of the warranty
9. Recommended spare parts list

Training - Meet all applicable Training requirements of Division 1, Division 15, and the following.

Instruct the operators how to accomplish control of the system. Include basic troubleshooting and override of equipment and controls in the event of system failure.

Training Allowance: Provide not less than 40 hours formal training to the Meriden Public Schools designated operations personnel.

Trainers - Persons conducting the training shall hold a Niagara4 certification, be knowledgeable in the workings of the system, and shall be regularly engaged in training exercises, so as to provide effective training.

Training Classes - Prior to conducting training, prepare and submit for approval the proposed training literature and topics. Submit this information at least two weeks prior to the first class.

Training - Manufacturer provided training on the use and operation of all products provided within these specifications shall be available for purchase and attendance by the Meriden Public Schools or his designated agent. Such training shall be of the same curriculum as the training courses provided by the manufacturer to the System Integrator. A manufacturer advanced 4 certified instructor shall give all training classes. A list of training courses and the

Temperature control

23 09 23- 6

**WASHINGTON MIDDLE SCHOOL
BOILER REPLACEMENT
1225 N BROAD STREET, MERIDEN CT 06450**

associated cost shall be provided as part of the BAS submittals.

Warranty

The HVAC Control System shall be free from defects in workmanship and material under normal use and service. If within twelve (12) months from the date of substantial completion or the Meriden Public Schools receives beneficial use of the system, the installed equipment is found to be defective in operation, workmanship or materials, the building systems contractor shall replace, repair or adjust the defect at no cost. Service shall be provided within the next business day upon notice from Meriden Public School's designated Representative.

The warranty shall extend to material that is supplied and installed by the Contractor. Material supplied but not installed by the Contractor shall be covered per the above to the extent of the product only. Installation labor shall be the responsibility of the trade contractor performing the installation.

All corrective software modifications made during warranty service periods shall be updated on all user documentation and on user and manufacturer archived software disks.

1.7 MERIDEN PUBLIC SCHOOLS OWNERSHIP OF PROPRIETARY MATERIAL

- A. Project-specific software and documentation shall become Meriden Public Schools property. This includes, but is not limited to:
1. Graphics
 2. Record drawings
 3. Database
 4. Application programming code
 5. Documentation
 6. Provide to the Meriden Public Schools the highest level administrative password for the system. This password is to be filed away by the Meriden Public Schools and not used during the warranty period. This is to protect the Meriden Public Schools interest in the system they purchased.

PART2 – PRODUCTS

2.1 Acceptable Manufactures

- A. Distech Controls by Connecticut Temperature Controls. (860) 788-3435. The new system shall be an extension of the existing campus wide supervisory server located at the Meriden Board of Education building.
- B. Controls shall be microprocessor based Interoperable Niagara4 Controllers in accordance with the JSR-60 Baja Specification. Inclusion on this list does not guarantee acceptance of products or installation. Control systems shall comply with the terms of this specification.

WASHINGTON MIDDLE SCHOOL
BOILER REPLACEMENT
1225 N BROAD STREET, MERIDEN CT 06450

1. The Contractor shall use only operator workstation software, controller software, custom application programming language, and controllers from the corresponding manufacturers and product line. The use of field level controllers from multiple manufacturers is acceptable provided no proprietary configuration or programming software is needed. **All field level controllers must be fully configurable through the Niagara4 automation level controller and the existing Niagara4 Campus Wide Supervisory Server. No additional tools, software or links to other servers/computers/systems shall be installed on this server.**
 2. Other products specified herein (such as sensors, valves, dampers, and actuators) need not be manufactured by the above manufacturers.
- 2.2 Networks – All Niagara 4 based network managers supplied under this section shall bridge the Lonworks, BACnet or ModBus field bus to the Meriden Public Schools Local Area Network (LAN) and/or Wide Area Network (WAN) as designated by the Meriden Public Schools. The network managers shall communicate at no less than 100 Megabits/sec over the Ethernet network and shall support BACnet over IP, Java, XML, HTTP, Fox and SOAP for maximum flexibility as it relates to the integration of building data with enterprise information systems. The system shall provide support for multiple network managers, Building Controllers (BC), user workstations and shall be fully configured through the exist campus wide site supervisor. The WAN and/or LAN will be provided by others. The SI shall coordinate with the General Contractor for the access to the WAN and/or LAN.
- A. Network minimum physical and media access requirements:
 1. Ethernet; IEEE standard 802.3
 2. Cable; 100 Base-T, UTP-8 wire, category 5
Minimum throughput; 100 Mbps
 - B. Network Access - Remote Access - For Local Area Network installations; provide access to the WAN and/or LAN from a remote location, via the Internet. This connection already exists to the existing campus wide site supervisor. The Meriden Public Schools will provide a WAN
- 2.3 Network - Field Level Controllers – The communication network between the field level controllers shall be Lonworks TP/FT 10 bus topology, BACnet MSTP, BACnet/IP, Modbus RS-485 or Modbus/IP. All wiring shall be provided in accordance with the standards for the appropriate protocol. The number of devices on any one network shall not exceed 90% of capacity.
- 2.4 Network Management Devices – These various devices will service multiple functions on the network depending on network design, communication medium and needed task. These functions can include: management of traffic on the network, reconfiguring and strengthening of signals, the conversion of protocols, normalizing of data, global management of alarms, trends and schedules, control logic, protocol conversion and web page hosting for use as a Graphical User Interface.

**WASHINGTON MIDDLE SCHOOL
BOILER REPLACEMENT
1225 N BROAD STREET, MERIDEN CT 06450**

- A. Building Controller (BC) – This Niagara Framework based device shall provide the interface between the LAN or WAN and the field control devices, and provide global supervisory control functions over the control devices connected to the BC.
1. It shall be provided with these features
 - a. Web page hosting
 - b. Extended memory
 - c. Network management tools resident within the BC (optional)
 - d. Appropriate hardware and driver(s) associated with the protocol it manages
 - e. Din rail mounted power supply
 2. Provide multiple Building Controllers as necessary. In order to maintain peak performance of the network, limit the maximum consumed resources to 80 percent as indicated by the resource meter resident in the network management tools.
 3. Provide for the creation of a minimum of eight of alarm classes for the purpose of routing types and or classes of alarms, i.e.: security, HVAC, Fire, etc. Manage alarms as defined in the points list.
 4. Provide timed (schedule) routing of alarms by class, object, group, or node.
 5. Provide alarm generation from binary object “runtime” and /or event counts for equipment maintenance. The user shall be able to reset runtime or event count values with appropriate password control. Control equipment and network failures shall be treated as alarms and annunciated.
 6. Alarms shall be annunciated in any of the following manners as defined by the user:
 - a. Screen message text
 - b. Email of the complete alarm message to multiple recipients.

Provide the ability to route and email alarms based on:

 - 1.Day of week
 - 2.Time of day
 - 3.Recipient
 - c. Pagers via paging services that initiate a page on receipt of email message
 - d. Graphic with flashing alarm object(s)
 - e. Printed message, routed directly to a dedicated alarm printer
 7. The following shall be recorded by the BC for each alarm (at a minimum):
 - a. Time and date
 - b. Location (building, floor, zone, office number, etc.)
 - c. Equipment (air handler #, access way, etc.)
 - d. Acknowledge time, date, and user who issued acknowledgement.

**WASHINGTON MIDDLE SCHOOL
BOILER REPLACEMENT
1225 N BROAD STREET, MERIDEN CT 06450**

- e. Number of occurrences since last acknowledgement.
 8. Alarm actions may be initiated by user defined programmable objects created for that purpose.
 9. Defined users shall be given proper access to acknowledge any alarm, or specific types or classes of alarms defined by the user.
 10. A log of all alarms shall be maintained by the BC and/or a server (if configured in the system) and shall be available for review by the user.
 11. A separate log for system alerts (controller failures, network failures, etc.) shall be provided and available for review by the user.
 12. A separate log for system alerts (controller failures, network failures, etc.) shall be provided and available for review by the user.
 13. Data Collection and Storage - The BC shall collect data for any property of any object and store this data as defined in the points list.
 14. The data collection shall be performed by log objects, resident in the BC that shall have, at a minimum, the following configurable properties:
 15. Designating the log as interval or deviation.
 16. For interval logs, the object shall be configured for time of day, day of week and the sample collection interval.
 17. For deviation logs, the object shall be configured for the deviation of a variable to a fixed value. This value, when reached, will initiate logging of the object.
 18. For all logs, provide the ability to set the maximum number of data stores for the log and to set whether the log will stop collecting when full, or rollover the data on a first-in, first-out basis.
 19. Each log shall have the ability to have its data cleared on a time-based event or by a user-defined event or action.
 20. Audit Log - Provide and maintain an Audit Log that tracks all activities performed on the BC. Provide the ability to specify a buffer size for the log and the ability to archive log based on time or when the log has reached its user-defined buffer size. Provide the ability to archive the log locally (to the BC), to another BC on the network, or to a server. For each log entry, provide the following data:
 - a. Time and date
 - b. User ID
 - c. Change or activity: i.e., Change setpoint, add or delete objects, commands, etc.
- B. Routers and Repeaters – A router or repeater may be used on a LON segment between controllers and a BC as a means to manage traffic and reconfigure and strengthen a transmission signal. Routers shall be fully programmable and permit a systems integrator to define message traffic, destination, and other network management functions utilizing LONWORKS. A repeater or signal booster may only be used to increase this signal strength of the communications. Under no circumstances may it be used in the place of a router.
- C. Campus Wide Server Supervisor – The entire building management system shall be integrated into the existing Niagara4 campus wide supervisor located at the

Temperature control

23 09 23– 10

**WASHINGTON MIDDLE SCHOOL
BOILER REPLACEMENT
1225 N BROAD STREET, MERIDEN CT 06450**

Board of Education Building. All programming and configuration on the existing Niagara4 Web Supervisor must be performed by Connecticut Temperature Controls as this company is responsible for this software's proper function and energy performance under a current contract with the MBOE. Connecticut Temperature Controls must perform all work on this software and server. This Contractor shall include all costs associated with the server integration and programming.

PART 3- BUILDING AUTOMATION SYSTEM CONTROLLERS

- 3.1 All controllers shall be designed for easy installation and servicing including removable enclosures, removable terminals, and factory applied labels for all I/O. All internal points within the Programmable Controllers shall be fully supported by the Graphical User Interface (GUI), allowing the user to easily modify them and monitor them. All of the internal programming points (e.g. variables, constants, PID's, timers, inputs and outputs) shall be exposed to the network on dedicated network variable outputs. All controllers programs and schedules shall contain non-volatile flash memory. Upon a loss of power all controllers shall perform a self-restart.
- 3.2 Programmable Controllers (PC) – a controller designed for more complex sequences of operations such as built up AHU, central plant operations, electrical monitoring, and control and management for chillers, boilers and generators. The PCs are to allow for the flexibility of custom control programming to meet the needed sequences of operation.
 - B. Performance – Each PC shall have a minimum of 64K of Non-volatile Flash memory for control applications and 128K non-volatile flash memory for storage with a 8 bit processor. The PC shall have a minimum ambient operating temperature range of -0°C to 70°C or 32°F to 158°F.
 - C. Inputs – Analog inputs shall have the following minimum level of performance: 16-bit A to D resolution; allow monitoring of platinum 100 ohms, platinum 1000 ohm, nickel 1000 ohms, thermistor 10K type II, thermistor 10K type III, voltage input 0-10VDC, current input 4-20mA, digital input, pulsed input minimum 2 Hz.
 - D. Outputs – Outputs shall be either software configurable to be either analog or digital or dedicated digital only - Analog outputs shall be selectable as voltage of 0-10 VDC (linear) or 4-20mA or Digital outputs shall be 0-12 VDC (off/on), floating or PWM. Outputs shall have an adjustable range of 2 seconds to 15 minutes. Output Resolution shall be a minimum 8 bits digital / analog converter. All individual outputs and power supply shall be protected by an auto reset fuse. There shall be an LED status indicator on each of the outputs.
 - E. Programmable Controller Features
 - 1. Provide an onboard network communication jack
 - 2. The PC shall be provided with a diagnostic indicator lights for power and network communication of transmit and receive along with a light indication position for each output

Temperature control

**WASHINGTON MIDDLE SCHOOL
BOILER REPLACEMENT
1225 N BROAD STREET, MERIDEN CT 06450**

3. LCD Operator Interface – For all controllers applied to a AHU, Chiller, Pumps Cooling Tower or Boiler Plant, provide a controller with a fully integrated LCD interface for manual override and adjustment of all Analog and Digital outputs. The LCD Operator interface shall be an integral part of the controller. LCD interface external from the controller shall not be accepted.
 4. Enclosures – Provide for an enclosure with a separate back plate with terminals such that the electronic portion of the controller can be easily removed for ease of installation and servicing.
- 3.3 Configurable Controllers (CC) - A controller designed through its I/O configuration and configurable control logic to be used for a specific type mechanical equipment.
- B. Performance: Inputs Provide software selectable universal inputs. Analog inputs - shall have the following minimum level of performance: 16 bit A to D resolution for all terminal box applications, 12 bit A to D resolution for all other configurable applications, manage thermistors with an accuracy of: $\square 0.5^{\circ}\text{C}$;
 $\square 0.9^{\circ}\text{F}$, and a Potentiometer
 - C. Output – Analog outputs shall have the following minimum level of performance: Tri-mode Voltage of 0-10 VDC (linear), digital 0-12 VDC (off/on) or PWM. All analog outputs shall be equipped with an auto reset fuse. Output Resolution shall be a minimum 8 bits digital / analog converter. Digital outputs shall be provided with a minimum of a triac output rated at 24VAC and 1 amp. All analog outputs shall be fuse protected
 - D. CC Features:
 1. The CC except for the VAV shall be provided with an optimum start program internal to its control logic. The optimum start shall be activated by a event signal from its associated scheduler on the network.
 2. The CC shall allow the use of its spare I/O as dumb I/O to be shared over the network to other controllers such as PC or the Building Controller (BC), where a sequence of operation can be applied to the I/O. Such applications shall include but not be limited to exhaust fan control, heaters, light control, etc.
 3. Enclosures – Provide for all CC except for the VAV, an enclosure with a separate back plate with terminals such that the electronic portion of the controller can be easily removed for ease of installation and servicing.
- 3.4 Special Purpose Configurable Controllers (SPCC) – A controller designed with unique functions and features particular to a specific type of mechanical equipment or applications that may be less common and or standardized in its use and application.
- B. SPCC – Thermostat (SPCCT) – A self contained controller with a built-in user interface that is intended for installation in the occupied space of the building.

**WASHINGTON MIDDLE SCHOOL
BOILER REPLACEMENT
1225 N BROAD STREET, MERIDEN CT 06450**

The SPCCT shall have the following features:

1. The SPCCT shall be a microprocessor based controller with all of its control logic, sensors, inputs and outputs, network communication and user interface provided within a manufacture provided enclosure specific to the application. The enclosure shall be aesthetically appealing with a modern design that will fit in with the architecture of the building. A sample of the SPCCT shall be provided as part of the submittal process.
2. The SPCCT shall be programmed through the user interface contained within the controller and through the LNS plug-in.
3. The User interface display shall be provided with 3 levels of password protection: Level 1 – Lockout with view only and time adjustment; Level 2 - schedule override and mode settings; Level 3 – full access to all parameters. The display shall be back lighted for easy viewing.
4. The SPCCT shall utilize a PI (proportional and integral) control algorithm. Upon power failure, all programmed schedules and parameters must be retained in non volatile flash memory. Progressive temperature recovery shall be a standard feature. Two configurable digital/binary inputs will be available as well as two remote temperature sensor inputs for outdoor air and remote room/return air monitoring. Built-in frost protection, which can be disabled, will energize the heating as soon as the ambient temperature falls below 45°F (5°C). An auxiliary digital/binary output, which can be configured for normally open or normally closed operation, will also be available.

C. Lighting Control (SPCC-LC) – A standalone microprocessor based control panel that contains line and or low voltage relays for control of the lighting circuits along with the appropriate schedules and local user interface.

1. The SPCC-LC shall provide as a minimum the following functionality;
 1. Occupant-Sensitive Operating Scenarios
 2. Schedule With Flick Warn
 3. Time-delay Overrides With Flick Warn
 4. Common Area Interlock With Egress Timer
 5. Master Switch Control With Flick Option
 6. Cleaning Lights
 7. Automatic Daylight Switching With Occupant Interlock/Override
 8. Status and Runtime Data
2. It shall manage input switches and sensors, output relays as well as lighting sequences and groups, enabling the user to configure and monitor a very large number of different lighting schemes and schedules.
3. Provide for a manual override of each circuit.
4. The SPCC-LC shall provide, as a minimum, the ability to interface with the hardware of the associated relay panels to allow for minimal disruption to the existing high voltage panel wiring. The SPCC-LC shall be capable of providing all logic, control, runtime data, status information, and communications functions.
5. If specified, provide a built-in LCD operator interface with the ability to read the status of the lighting relays and switches and implement temporary override command.

Temperature control

PART 4 - BAS SOFTWARE TOOLS

- 4.1 Provide 5 copies of all tools necessary for the development, maintenance, expansion and use of the BAS described within these specifications. All software tools shall be a part of the Niagara Framework tools or be provided as Wizards that operates within the Niagara Framework environment. For the purpose of this specification software tools shall be divided into the following categories and meet these specified requirements.
- B. Controller Programming Software
1. Provide Wizards or objects that facilitate the programming and configuration of the Configurable Controllers (CC), Programmable Controller (PC) and or the Special Purpose Configurable Controllers (SPCC) sequence of operation through menu driven wizard. The programming tools shall perform the following functions:
 1. PC programming shall be accomplished by graphical programming language (GPL) where objects are used to define different portions of the control sequence. All control sequences programmed into the PC shall be stored in non-volatile memory. Systems that only allow selection of sequences from a library or table are not acceptable. All code must be exportable to a library for future use.
 2. CC and SPCC – Provide for the programming of the required sequence of operation through an intuitive configuration menu driven selection process. The configuration tools menu shall define items such as I/O configurations, set point, delays, PID loops, optimum start stops, and network variables settings. The configuration tool must indicate the device status and allows system override. Graphical programming language as described for the PC is acceptable.

**WASHINGTON MIDDLE SCHOOL
BOILER REPLACEMENT
1225 N BROAD STREET, MERIDEN CT 06450**

- 4.2 The Graphical User Interface (GUI) shall employ browser-like functionality for ease of navigation. It shall include a tree view (similar to Windows Explorer) for quick viewing of, and access to, the hierarchical structure of the database. In addition, menu-pull downs, and toolbars shall employ buttons, commands and navigation to permit the operator to perform tasks with a minimum knowledge of the HVAC Control System and basic computing skills. These shall include, but are not limited to, forward/backward buttons, home button, and a context sensitive locator line (similar to a URL line), that displays the location and the selected object identification.
- A. Provide a visual graphical representation of each piece of mechanical equipment and/or mechanical system that duplicates the represented system, where applicable. Graphics shall include at a minimum the value of each input, each output, each setpoint, alarms and graphical representation of trend logs. The graphic shall provide for the ability to command each point, including both timed and permanent overrides. In addition, provide for all information represented in the graphics in an associated graphical table with links to the equipment graphics and commandable points. All graphics shall commiserate with latest industries standards and practices. Sample graphics shall be provided as part of the submittals for approval by Meriden Public Schools.
- B. Real-Time Displays. The GUI, shall at a minimum, support the following graphical features and functions:
1. Graphic screens shall be developed using any drawing package capable of generating or assembling objects from a GIF, or JPG file format. Use of proprietary graphic file formats shall not be acceptable. In addition to, or in lieu of a graphic background, the GUI shall support the use of scanned pictures.
 2. Graphic screens shall have the capability to contain objects for text, real-time values, animation, color spectrum objects, logs, graphs, HTML or XML document links, schedule objects, hyperlinks to other URL's, and links to other graphic screens.
 3. Modifying common application objects, such as schedules, calendars, and set points shall be accomplished in a graphical manner.
 - a) Schedule times will be adjusted using a graphical slider, without requiring any keyboard entry from the operator.
 - b) Holidays shall be set by using a graphical calendar, without requiring any keyboard entry from the operator.
 4. Commands to start and stop binary objects shall be done by right- clicking the selected object and selecting the appropriate command from the pop-up menu. No entry of text shall be required.

**ROGER SHERMAN ELEMENTARY SCHOOL
BOILER REPLACEMENT AND TEMPERATURE CONTROL UPGRADES
MERIDEN, CONNECTICUT
PROJECT# B018-14**

5. Adjustments to analog objects, such as set points, shall be done by right-clicking the selected object and using a graphical slider to adjust the value. No entry of text shall be required.
- C. System Configuration. At a minimum, the GUI shall permit the operator to perform the following tasks, with proper password access:
1. Create, delete or modify control strategies.
 2. Add/delete objects to the system.
 3. Tune control loops through the adjustment of control loop parameters.
 4. Enable or disable control strategies.
 5. Generate hard copy records or control strategies on a printer.
 6. Select points to be alarm-able and define the alarm state.
 7. Select points to be trended over a period of time and initiate the recording of values automatically.
- D. On-Line Help. Provide a context sensitive, on-line help system to assist the operator in operation and editing of the system. On-line help shall be available for all applications and shall provide the relevant data for that particular screen. Additional help information shall be available through the use of hypertext. All system documentation and help files shall be in HTML format.
- E. Security. Each operator shall be required to log on to that system with a user name and password in order to view, edit, add, or delete data. System security shall be selectable for each operator. The system administrator shall have the ability to set passwords and security levels for all other operators. Each operator password shall be able to restrict the operators' access for viewing and/or changing each system application, full screen editor, and object. Each operator shall automatically be logged off of the system if no keyboard or mouse activity is detected. This auto log-off time shall be set per operator password. All system security data shall be stored in an encrypted format.
- F. System Diagnostics. The system shall automatically monitor the operation of all workstations, printers, modems, network connections, building management panels, and controllers. The failure of any device shall be annunciated to the operator.
- G. Alarm Console
1. The system will be provided with a dedicated alarm window or console. This window will notify the operator of an alarm condition, and allow the operator to view details of the alarm and acknowledge the alarm. The

**ROGER SHERMAN ELEMENTARY SCHOOL
BOILER REPLACEMENT AND TEMPERATURE CONTROL UPGRADES
MERIDEN, CONNECTICUT
PROJECT# B018-14**

use of the Alarm Console can be enabled or disabled by the system administrator.

2. When the Alarm Console is enabled, a separate alarm notification window will supersede all other windows on the desktop and shall not be capable of being minimized or closed by the operator. This window will notify the operator of new alarms and un-acknowledged alarms. Alarm notification windows or banners that can be minimized or closed by the operator shall not be acceptable.

PART 5 - USER INTERFACES

A. Web Browser Clients – shall be capable of total integration of the facility infrastructure systems with user access to all system data either locally over a secure Intranet within the building or by remote access by a standard Web Browser over the Internet. **Systems requiring additional software (to enable a standard Web browser) to be resident on a client machine, or manufacture-specific browsers shall not be acceptable.**

5.1 Provide for a series of browser accessible graphical screens that are resident on the Campus Wide Server that represent the systems controllers and managed by that server and its associated controllers.

A. The Web browser client shall support at a minimum, the following functions:

A. Unlimited concurrent users shall be able to simultaneously login without the need of any additional user licenses or fees.

B. User log-on identification and password shall be required. If an unauthorized user attempts access, a blank web page shall be displayed. Security using Java authentication and encryption techniques to prevent unauthorized access shall be implemented.

C. Graphical screens developed for the GUI shall be the same screens used for the Web browser client. Any animated graphical objects supported by the GUI shall be supported by the Web browser interface.

D. HTML programming shall not be required to display system graphics or data on a Web page

E. Storage of the graphical screens shall be in the Building Controller (BC), without requiring any graphics to be stored on the client machine. Systems that require graphics storage on each client are not acceptable.

F. Real-time values displayed on a Web page shall update automatically without requiring a manual “refresh” of the

**ROGER SHERMAN ELEMENTARY SCHOOL
BOILER REPLACEMENT AND TEMPERATURE CONTROL UPGRADES
MERIDEN, CONNECTICUT
PROJECT# B018-14**

Web page.

- G. Users shall have administrator-defined access privileges. Depending on the access privileges assigned, the user shall be able to perform the following:
 - A. Modify common application objects, such as schedules, calendars, and set points in a graphical manner.
 - A. Schedule times will be adjusted using a graphical slider, without requiring any keyboard entry from the operator.
 - B. Holidays shall be set by using a graphical calendar, without requiring any keyboard entry from the operator.
 - B. Commands to start and stop binary objects shall be done by right-clicking the selected object and selecting the appropriate command from the pop-up menu. No entry of text shall be required.
 - C. View logs and charts
 - D. View and acknowledge alarms
- H. The system shall provide the capability to specify a user's (as determined by the log-on user identification) home page. Provide the ability to limit a specific user to just their defined home page. From the home page, links to other views, or pages in the system shall be possible, if allowed by the system administrator.
- I. Graphic screens on the Web Browser client shall support hypertext links to other locations on the Internet or on Intranet sites, by specifying the Uniform Resource Locator (URL) for the desired link.

PART 7 - EXECUTION

7.1 INSTRUCTION AND ADJUSTMENTS

Upon completion of the project, the Temperature Control Contractor shall: Check, validate, and calibrate, where required, all controllers, controlled devices, valves, actuators, auxiliary devices, relays, etc. provided under this section.

7.2 COORDINATION

**ROGER SHERMAN ELEMENTARY SCHOOL
BOILER REPLACEMENT AND TEMPERATURE CONTROL UPGRADES
MERIDEN, CONNECTICUT
PROJECT# B018-14**

Coordinate the controls furnished under this section with the controls furnished with the boilers and chillers resulting in a complete system properly interfaced.

7.3 SYSTEM TURN OVER

Upon completion of the installation, the Control Contractor shall start-up the system and perform all necessary testing and run diagnostics to ensure proper operation. An acceptance test in the presence of the Meriden Public Schools Representative, the Architect, or the Engineer shall be performed. The acceptance test shall consist of a point-to-point check-out within each terminal unit controller to insure proper operation of all system components.

When the system is deemed satisfactory in whole or in part by these observers, the system parts will be accepted for beneficial use and placed under warranty.

Problems which occur within approved hardware or software shall be corrected in an appropriate fashion under warranty. Any such occurrence shall not void previous approval; however, the Control Contractor shall be responsible to attend to, and remedy, such items within the warranty period. Appropriate logs, schedules, and reports shall be maintained to reflect these items and their redress.

7.4 TRAINING/MERIDEN PUBLIC SCHOOLS'S INSTRUCTION

- A. The Control Contractor shall provide two (2) copies of an operator's manual describing all operating and routine maintenance service procedures to be used with the system. The Control Contractor shall instruct the Meriden Public Schools designated representative in these procedures during the start-up and test period. The duration of the instruction are to be conducted during normal working hours and shall be no less than sixteen (16) hours divided in (4), four hours sessions.

END OF SECTION 23 09 23

PART 1 - GENERAL

1.1 RELATED DOCUMENTS:

- A. The General Provisions of the Contract, including General and Supplementary Conditions and General Requirements, apply to the work specified in this Section.
- B. The General Requirements in Section 200050 shall also govern the work under this Section.
- C. Examine all drawings and data and coordinate the work of this Section with all related and adjoining work.

1.2 SCOPE OF WORK:

- A. This Contract includes all labor, material, equipment, tests and appliances required to furnish and install all HVAC as shown on drawings, implied and herein specified.
- B. The present location of the building will be as shown on drawings. Visit the site and examine the Mechanical trades showing all details of construction before submitting proposal.
- C. Connect new boilers and pumps to existing and leave ready to operate. Check all Mechanical and Electrical drawings and coordinate all work accordingly.
- D. Refer to Section 230548 for Seismic Restraints.
- E. Drawings are diagrammatic and indicate the general arrangement of piping and do not show all minor details and fittings. Such items shall be included, as well as reasonable modification, in the layout as directed to prevent conflict with other trades.

1.3 SUBMITTALS:

- A. In accordance with Section 200050, the following items shall be submitted for review.

Pipe and fittings Pumps
Hydronic Equipment and Specialties
Boiler

1.4 MOTOR CONTROL:

- A. Each electric motor of 3 phase characteristics shall be furnished with an automatic starter as specified in Section 200050, Motor Control.

**WASHINGTON MIDDLE SCHOOL
BOILER REPLACEMENT
1225 N BROAD STREET, MERIDEN CT 06450**

PART 2 -PRODUCTS

2.1 PIPE AND FITTINGS:

A. Copper Tubing:

1. Type "L", ASTM Specifications B88, shall be used for water lines.
2. Fittings shall be wrought copper or cast brass solder- joint pressure rated type.
3. Type "K" shall be used for underground piping with flared fittings.

B. Steel Piping:

1. Pipe shall be Standard Wall (Sch. 40) black carbon steel, ASTM A-120, Grade B, with threaded ends for sizes 1/2" through 2", for hot water heating piping.
2. All steam condensate return piping shall be run in (SCH 80) black steel.
3. Fittings shall be standard weight (125 lbs.), cast iron screwed, ASTM A126, Class A, for sizes 1/2" through 2". Piping 2" and under shall be screwed.
4. Victaulic Grade E couplings, fittings and accessories in conjunction with grooved end schedule 40 piping will be permitted in existing and new construction for hot water heating system.

2.2 PIPE AND FITTINGS:

- A. All fittings on welded lines shall be furnished in accordance with ASTM A105 Specification designed for welding. Branch outlets on mains 2-1/2" and smaller to be made with Weldolets or Threadolets. Welding fittings on mains and branches 3" and larger are to be full size of reducing tube designed for welding.
All flanged valves 3" and larger and special equipment connections to be installed with weld neck flanges for welded construction.
- B. All nipples shall be extra strong as follows: Pipe size 1/2" to 4" - 6" close. Pipe size 5" - 12" - 12" close and of the same material as the piping they are used with.
- C. All copper tubing shall be furnished in Type "L" using sweat fittings unless otherwise noted. Copper tubing shall be furnished in Chase, Anaconda, Bridgeport or Revere.
- D. All black steel over 4" or other welded pipe shall have long radius welding ells and tees of the same wall thickness as the pipe. Welding tees will not be required where the mains and branches comply with the following schedule:

Min. Size of Mains

Max. Size of Branch

2 1/2"	3/4"
3"	1 1/4"
4"	2"
5"	3"
6"	4"
8"	6"

WASHINGTON MIDDLE SCHOOL
BOILER REPLACEMENT
1225 N BROAD STREET, MERIDEN CT 06450

10"	8"
12"	10"

- E. Welding flanges shall be slip-on or welding neck type, 300 psig forged steel conforming to ANSI Specification B-16.5.
- F. All necessary precautions shall be taken when welding in the new building to prevent combustion of structure.

2.3 GROOVE PIPING:

- A. Victaulic couplings may be used in lieu of welding, thread or flanging on 2 1/2" through 30" carbon steel pipe, on heating water services from -30 deg. F. to 230 deg. F. within the manufacturer's rated working pressures. Pipe grooving shall be cut grooved and/or rolled grooved as per manufacturer's latest spec. Installation is per manufacturer's latest recommendations. All piping shall be Schedule 40. grooved piping shall be used only in concealed or service areas. Grooved piping will not be accepted in finished areas with no ceiling.
- B. Piping Components - Grooved couplings consisting of two or more pieces of ductile or malleable iron. Coupling gaskets will be a synthetic rubber gasket with a central cavity pressure responsive design. Coupling bolts and nuts shall be heat treated carbon steel, track head conforming to physical properties of ASTM-A-183. All grooved couplings shall be as manufactured by Victaulic Co. Style 77, 07 or equal.
- C. For piping 2 1/2" and larger, full size branch connections shall be made with manufactured grooved end tees. Branch connections for less than full size shall be made with Victaulic hole cut products. Style 920 or Style 921 branch connections with locating collar engaging into hole or style 72 outlet coupling used to join grooved pipe and to create a branch connection. Gaskets for branch connection shall be Victaulic Grade "E" EPDM Compound with working temperature of -30 deg. F. to 230 deg. F.
- D. Flanges - Vic-Flange Style 741 (2-24") for connection to ANSI class 125 and 150 flanged components.
- E. Fittings - Fittings shall be full flow cast fittings, steel fittings or segmentally welded fittings with grooves or shoulders designed to accept Victaulic grooved end couplings.
 - 1. Standard Fittings - shall be cast of ductile iron conforming to ASTM A-536 (Grade 65-45-12) or malleable iron conforming to ASTM A-47, Grade 32510, painted with a rust inhibiting modified vinyl Alkyd enamel or hot-dip galvanized to ASTM A-153 or zinc electroplated to ASTM B-633, as required.
 - 2. Standard Steel Elbow Fittings - (14" - 24"), shall be forged steel conforming to ASTM A-106 Grade B (0.375" wall), painted with rust inhibiting modified vinyl Alkyd enamel or hot-dip galvanized to ASTM A-153.
 - 3. Standard Segmentally Welded Fittings - shall be factory fabricated, by fitting manufacturer, of carbon steel pipe as follows, 3/4" - 4" conforming to ASTM A-53, Type F; 5" - 6" Sch. 40 conforming to ASTM A-53, Type E or S, Grade B; 8" - 12" Sch. 30 conforming to ASTM A-53, Type E or S, Grade B; 14" - 24" 0.375" wall

**WASHINGTON MIDDLE SCHOOL
BOILER REPLACEMENT
1225 N BROAD STREET, MERIDEN CT 06450**

conforming to ASTM A-53, Type E or S, Grade B, painted with rust inhibiting modified vinyl Alkyd enamel or hot-dip galvanized to ASTM A-153, as required.

- F. Victaulic Pipe Hanging (Victaulic Hanging Standard A-130)
1. Style 07 Zero-Flex for rigid piping systems should be supported as per Building Services B31.9 Hanging.
 2. Style 77 flexible piping systems are supported as per Victaulic Hanging Standard A-130.

2.4 PIPING JOINTS:

- A. Welded Joints shall be fusion welded in accordance with American Standard B31.1, Section 6, except as modified hereinafter. Changes in direction of piping shall be made with welding fittings only. Mitering, notching or direct welding of pipe to the main in order to form tees or ells will not be permitted. Branch connections may be made with welding tees or forced branch outlet fittings, as manufactured by Bonney Forge, either being acceptable without size limitation. Bonney Thredolets shall be used in lieu of Hald couplings when reducing from a welded run to a screwed branch. Outlet fittings where used shall be forged, flared for improved flow where attached to the run, reinforced against external strains and designed to maintain full pipe bursting strength. Fillet welds shall be used for welding screwed and slip-on steel flanges to pipes. Where lateral connections are to be used, either lateral fittings or Bonney Latrolets are acceptable. Wedded joints shall be used in finished areas with no ceiling.
- B. Screwed Joints: The ends of pipes to be threaded shall be cut square and reamed. Pipe threads shall be standard taper, shall be cut straight and clean and to full depth, and shall be free from dirt, chips and burrs when the joint is made. Pipe joint lubricant or compound shall be selected for the pipe line service and shall be applied to male threads only. Screwed joints shall not be caulked.
- C. Flanged Joints: This heading covers flanged joints of all types, including those made with flange unions. Flanged joints shall be made with suitable reinforced gaskets. Clean all parts and align the joint before assembling; support pipes or heavy parts independently. Opposite bolts shall be pulled up successively. Screwed steel flanges shall be welded to pipes; slip-on steel flanges shall be welded front and back.
- Cast iron flanges shall not be welded to pipes. If raised face flanges are to be bolted against plain face flanges, the raised face shall be removed and a full face gasket used. Where flanged base elbows are installed, the base shall not be used for anchoring the line or otherwise subjected to tension or shear.
- D. Soldered Joints in Copper Tubing: Cut the ends of tubes square, remove burrs, clean tube ends and fitting sockets with emery cloth and remove all particles before applying flux and making the joint. Insert tubes to full socket depth. Use the following solders at the given conditions.

95 - 5% Tin-Antimony/all services/high pressure 250 degrees F. Max.
Silver - 35 to 45% alloy-refrigerant piping/high pressure and temperature.

**WASHINGTON MIDDLE SCHOOL
BOILER REPLACEMENT
1225 N BROAD STREET, MERIDEN CT 06450**

2.5 PIPE HANGERS:

- A. Securely hang and anchor pipe as shown and required with proper provision for expansion, contraction and elimination of undue stress and strain on piping.
- B. Provide a pipe hanger within two (2) feet of each elbow, tee, wye, valve, strainer and similar device.
- C. Secure and support runs at base and at sufficiently close intervals to hold pipe at alignment and to carry safely the weight of piping and contents without undue stress thereon.
- D. Except as indicated to the contrary, secure and support all horizontal piping as follows and required to prevent sagging, undue pipe movement and preserve proper alignment in each run.

<u>Piping</u>	<u>Sizes</u>	<u>Maximum Interval</u>
Cast Iron	All sizes	At each hub or joint
Steel	2" & smaller	Six (6) feet
Steel	2 1/2" & larger	Ten (10) feet
Copper Tubing	1 1/4" & smaller	Five (5) feet
Copper Tubing	1 1/2" & larger	Eight (8) feet

- E. Hangers up to and including 2" shall be the adjustable band type equal to Empire. Figure 310 for iron pipe and Fig. 310CT for copper tubing.
- F. Hangers for piping 2-1/2" and up shall be the clevis type, equal to Empire. Figure 11 for iron pipe and Figure 110CT for copper tubing.
- G. Hangers shall be suspended from one of the following devices:
 - 1. "C" clamps.
 - 2. Trapeze hanger assemblies consisting of back-to-back horizontal steel channels with end-type rod hangers.
 - 3. Expansion shield embedded into concrete or masonry.
- H. On hot water systems, provide over-sized hangers.
- I. Refer to Section 15010 for Seismic Restraints.

2.6 VALVES:

- A. This Contractor shall furnish and install valves where shown on plans and also wherever necessary to make the system complete in its operation. All valves shall be as manufactured by Stockham, Jamesbury, Centerline, Appollo, Milwaukee and Victaulic.

Hot Water Heating

2" and smaller

Ball valves	Apollo 71-100/200
Check valves	Stockham B-310-T

**WASHINGTON MIDDLE SCHOOL
BOILER REPLACEMENT
1225 N BROAD STREET, MERIDEN CT 06450**

Vertical check valves Stockham B-310-T

2-1/2" and larger

Butterfly valves Stockham - LG712-BS3-B (Lug Style)

Check valves Centerline - Series 800 S.S. plate and spring, and nypalon seats.

Furnish all valve materials suitable for service intended. No gate valves shall be allowed.
Provide all valves with factory installed extension stems.

2.7 UNIONS:

- A. All unions shall be furnished in Nibco-633 or equal in Chase, Revere, Jefferson and Anaconda.

2.8 GASKETS:

- A. Where flanges occur, they shall be packed with Klinger or approved equivalent high quality non-asbestos material composed of fibers for industrial maintenance service with high chemical stability and heat resistance. Nitrile rubber bonded.

Temperature 750 deg. F. max.

Pressure 1450 psi max.

Compressibility ASTM F36A

Tensile Strength ASTM F152

2.9 REAMING OF PIPES:

- A. All pipes to be carefully reamed after cutting and threading.

2.10 PIPE ANCHORS:

- A. Furnish and install all steel clamps around mains not less than 1/4" thick and welded to pipe and necessary angle braces to substantial construction to meet job conditions. Anchored mains shall be properly guided.
- B. Vertical risers, if any, shall be anchored by similar clamps secured to floor, concealed in wall construction.

2.11 HANGERS AND SLEEVES:

- A. All horizontal piping shall be supported in a good, firm and substantial manner. No chains, horizontal pieces of pipe or hangers formed by means of perforated steel bands, pipe rings and hooks will be permitted. All hangers shall be oversized
- B. All pipes passing through walls or partitions shall be provided with sleeves sized to give a minimum of 1/2" clearance between sleeve and the outside diameter of the pipe or insulation enclosing the pipe.

**WASHINGTON MIDDLE SCHOOL
BOILER REPLACEMENT
1225 N BROAD STREET, MERIDEN CT 06450**

2.12 SPECIALTIES FOR HOT WATER SYSTEM:

- A. Furnish and install all hot water equipment in Bell & Gossett as specified below and as shown on the drawings.
 - 1. Pressure reducing valve for each closed system.
 - 2. B & G Triple Duty flow control valves shall be furnished in either the angle type or straightaway to suit each individual location and full size of each main or branch main.
 - 3. Provide B&G circuit setter plus calibrated balancing valves Model C.B. on air handling equipment.

- B. Furnish and install the following accessories and equipment in make other than Bell & Gossett.
 - 1. Thermometers: Install Ashcroft Fig. 7173T BI-Metal "Every Angle" thermometers where shown and/or called for on plans or in specifications.
 - 2. Thermometers shall have 5" aluminum hermeticism sealed case with stainless steel stem with 1/2" NPT connection. Install in separable well in brass with lagging extension neck. Stem length and dial range shall be 6" and 0 degrees to 250 degrees F., respectively.
 - 3. Furnish and install on non-critical systems, gauges suitable for use on hot water where indicated on drawings or called for in specifications. Gauge shall be Ashcroft Fig. 2070 with silver brazed boudon tube, aluminum back flange type epoxy coated case, chrome ring, 1/4" NPT lower connection, stainless steel movement with 1% accuracy. Pressure range shall be as required. Furnish 1/4" needlepoint valve in Crane #88 for each gauge. Where sharp pressure fluctuations may occur, mount gauge on a 1/4" Fig. 1106B pulsation dampener. Provide compound gauges where required or called for.
 - 4. Furnish and install gauges on all pump discharge and compound gauges on all pump suction.
 - 5. Furnish and install balancing valves on air handling unit coil, etc., runouts 2" and smaller in Tour Andersson STA-D Series with "A metal" construction. Branch mains 2 1/2" and larger shall be provided with Tour Andersson STA-F Series balancing valve.
 - 6. Furnish and install dielectric fittings.

2.13 IN-LINE MOUNTED CENTRIFUGAL PUMPS:

- A. Furnish and install the in-line centrifugal pumps complete with motors and trim meeting the performance, size, electrical requirements as scheduled or otherwise specified in Bell & Gossett. Maximum operating temperature shall be 225 degrees F with a maximum working pressure of 175 PSI.

- B. All in-line centrifugal pumps shall be furnished complete with motor and trim suitable for service indicated on plans or otherwise specified. Pump volute shall be of cast iron design. Volute shall include gauge, vent and drain ports. The connection style shall be flanged. The mechanical contractor shall coordinate system connection sizes with trim and pump size and provide all fittings and hardware necessary to connect pump to system piping. . The pump

**WASHINGTON MIDDLE SCHOOL
BOILER REPLACEMENT
1225 N BROAD STREET, MERIDEN CT 06450**

internals shall be capable of being serviced without disturbing piping connections to the pump.

- C. Furnish motors for all in-line centrifugal pumps meeting the electrical requirements scheduled and specified in accordance with specification section 15010. All 120 volt motors shall be supplied with built in thermal overload protection.
All three phase motors of 1HP or greater shall be supplied as premium efficiency motors. Motors shall be selected to be non-overloading at any point along the pump curve and shall meet NEMA specifications.
- D. Pumps shall be of the maintainable design. Provide City of Meriden with complete parts list with service information.
- E. Each pump shall be factory tested per Hydraulic Institute standards and name-plated prior to shipment. Impeller shall be both hydraulically and dynamically balanced, keyed to the shaft and secured by a locking cap screw or nut.
- F. Each pump shall have a three year warranty from the date of installation.
- G. Each pump shall be factory primed and painted to prevent rust and corrosion of the pump exterior surfaces.
- H. Provide seismic restraints and vibration isolation for each pump in accordance with specification section 15010.
- I. Pump shall be installed, aligned and started in accordance with manufacturer's recommendations
- J. Long-Coupled In-Line Pump (B&G Series 60)
 - 1. Long-Coupled In-Line centrifugal pumps shall be horizontal, permanently lubricated and specifically designed and guaranteed for quiet operation. The pump shall be single stage, vertical split case design in cast iron bronze fitted construction
 - 2. The pump shall be composed of three separable components: a motor, bearing assembly and pump end (wet end). The motor shaft shall be connected to the pump via a replaceable flexible coupler. The pump shall have a solid SAE 1144 steel shaft supported by two sealed ball bearings. A non-ferrous shaft sleeve shall be employed to completely cover the wetted area under the seal. The pump shall be equipped with an internally flushed mechanical seal assembly. Seal assembly shall have a brass housing, Buna bellows and seal gasket, stainless steel spring, and be of carbon ceramic design with the carbon face rotating against the stationary ceramic face.
 - 3. A flexible-type coupling shall be employed between the pump and motor. To ensure alignment, the motor shall be mounted to the bearing assembly via a bolted motor bracket assembly with a rubber motor mount.
 - 4. The pump shall be designed to allow for true back pull-out access to the pumps working components.

**WASHINGTON MIDDLE SCHOOL
BOILER REPLACEMENT
1225 N BROAD STREET, MERIDEN CT 06450**

- K. Close-Coupled In-Line Pump (B&G Series 80 & 90)
1. Close-Coupled In-Line centrifugal pumps shall be single stage design suitable for installation in vertical or horizontal positions, permanently lubricated and specifically designed and guaranteed for quiet operation.
 2. Pump casing shall be Class 30 cast iron, bronze fitted. The impeller shall be cast bronze, closed type
 3. The liquid cavity shall be sealed off at the motor shaft by an internally-flushed mechanical seal with ceramic seal seat and carbon seal ring, suitable for continuous operation. A bronze shaft sleeve shall completely cover the wetted area under the seal.

2.14 BASE MOUNTED CENTRIFUGAL PUMPS:

- A. Furnish and install the base mounted centrifugal pumps complete with motors and trim meeting the performance, size, electrical requirements as scheduled or otherwise specified in Bell & Gossett. Maximum operating temperature shall be 225 degrees F with a maximum working pressure of 175 PSI.
- B. All base mounted centrifugal pumps shall be furnished complete with motor and trim suitable for service indicated on plans or otherwise specified. Pump shall be of the single stage end suction design with a class 30 cast iron volute with a foot integrally cast to the pump. Volute shall include gauge, vent and drain tapings. The connection style shall be flanged. The mechanical contractor shall coordinate system connection sizes with trim and pump size and provide all fittings and hardware necessary to connect pump to system piping. The pump internals shall be capable of being serviced without disturbing piping connections to the pump.
- C. The pump impeller shall be cast bronze enclosed type (bronze fitted). The liquid cavity shall be sealed off at the pump shaft by an internally-flushed mechanical seal with ceramic seat and carbon steel ring. Replaceable bronze shaft sleeve shall completely cover the wetted area under the seal.
- D. Pump shall come from the factory fully assembled and mounted to a baseplate. The baseplate shall be of structural steel with fully enclosed sides and ends and securely welded cross members. Grouting area shall be fully open.
A flexible type, center dropout design coupler capable of absorbing torsional vibration shall be employed between the pump and the motor. Coupler shall be shielded by an ANSI/OSHA compliant coupler guard securely fastened to the base frame.
- E. Furnish motors for all base mounted centrifugal pumps meeting the electrical requirements scheduled and specified in accordance with specification section 15010. All three phase motors of 1HP or greater shall be supplied as premium efficiency motors.

Motors shall be selected to be non-overloading at any point along the pump curve and shall meet NEMA specifications. Pump and motor shall be factory aligned and (if required) re-aligned in the field by the installing contractor.
- F. Pumps shall be of the maintainable design. Provide West Hartford Public Schools with

**WASHINGTON MIDDLE SCHOOL
BOILER REPLACEMENT
1225 N BROAD STREET, MERIDEN CT 06450**

complete parts list with service information.

- G. Each pump shall be factory tested per Hydraulic Institute standards and name-plated prior to shipment. Impeller shall be both hydraulically and dynamically balanced, keyed to the shaft and secured by a locking cap screw or nut.
- H. Each pump shall have a three year warranty from the date of installation.
- I. Each pump shall be factory primed and painted to prevent rust and corrosion of the pump exterior surfaces.
- J. Mechanical contractor to provide pressure gauges vents and other trim for each base mounted pump. Pump shall be installed, aligned and started in accordance with manufacturer's recommendations.
- K. Provide seismic restraints and vibration isolation for each pump in accordance with specification section 230548.

2.15 CHEMICAL FEEDING EQUIPMENT :

- A. For each closed system the Contractor shall furnish and install the following apparatus (including isolation and drain valves):
 - 1. One shot combination filter feeder, minimum five gallon capacity with quarter turn cap and 3 ½" opening. The feeder shall be rated for 200 psi service.
- B. The Contractor shall provide ports to test the chemical concentration.
- C. Furnish one year's supply of filters and the formulas for control of scale and corrosion in the closed hot water recirculating system. Formulations shall not contain any ingredients which may be harmful to system materials of construction. Provide MSD sheets on all chemical products. No system shall be operated without the benefit of chemical protection. Once the recommended chemical residual is achieved, any additional chemicals required to re-treat the system due to water loss or to accomplish other work shall be provided by the Mechanical Contractor.

2.16 CONDENSING BOILERS

- A. Work Included: Provide equipment, labor, materials and services as required for the complete installation of three boiler/burner units.
- B. Submittals: Provide manufacturer's catalog brochures and technical data for boiler[s], burner[s], accessories.
- C. Boiler and burner installation shall comply with all state and local code requirements. Contractor shall obtain installation permit prior to installation and a certificate of boiler inspection after the installation has been completed and shall pay all fees associated with those requirements.

**WASHINGTON MIDDLE SCHOOL
BOILER REPLACEMENT
1225 N BROAD STREET, MERIDEN CT 06450**

- D. General - Furnish and install as shown on plans in accordance with all codes and authorities having jurisdiction, Boiler Plant Model BMK-3000LN-2. Plant shall consist of 2 multiple boilers, Model BMK-3,000LN as manufactured by AERCO International, Inc.. Boilers shall be UL/FM approved and have a total input of 3,000mbh with a combined output rating of 5,580mbh. Each boiler shall have an input of 3,000mbh when fired with natural gas. Boiler Plant shall provide maximum Interval Part Load Value (IPLV) efficiency throughout the entire heating season.

Substitutions shall be considered on their ability to fit the design documents without substantial modification or redesign of system schematic and the ability to meet the design temperature schedule. All requests for alternate consideration shall require a full set of plans indicating details, locations, sizing, integration into existing mechanical room and control sequence for engineers review. All boiler manufacturers shall have a minimum of 5 years field experience and operation in similar low temperature systems for consideration.

- E. Electrical Service - Single point connection to each unit shall be 480V/3/60Hz 10 amp service. The boiler control panel shall be proprietary in design and incorporate the functions of temperature control, combustion safeguard control, message annunciation, and fault diagnostic display, on individual field replaceable circuit boards mounted within a single housing. Each boiler shall have a footprint of no more than 28" W, 68.4" D, 79.8" H with a UL Listing for zero sidewall clearance. The boiler installed weight shall not exceed 2,170 lbs. dry.
- F. Boiler piping shall be primary to the system flow, without the use of pumps or other energy consuming devices. Multiple independently fired boilers shall be installed as shown on the plans and as per the manufacturer's standard instructions. Each unit shall be valved and capable of being isolated from the system if needed. Units shall be suitable to accept system flow and temperature fluctuations at any point along the system design reset schedule without thermal shock or condensation restriction.
- G. Efficiency - System supply temperature at design conditions shall be 200F, with a 20F degree temperature differential at full design load. Boilers requiring a higher differential or not delivering equal thermal efficiency will not be considered as equal or acceptable. Each independent boiler shall be Low NOx discharge and meet the SCQAMD qualifications for clean emissions. Boiler manufacturer shall supply certificate of approval with boiler submissions for engineers review and verification.

Boiler shall be supplied with confirmed thermal efficiency performance profile by a third party national testing agency, such as UL or CSA. Boiler manufacturer shall supply partial and full load efficiency performance at various return water temperatures and various input firing. A single test point shall not be considered equal.

- H. Boiler Construction – Each boiler shall be of natural gas fired, condensing fire tube design with a modulating power burner and positive pressure discharge. Boilers shall be ANSI Class IV.
- I. Modulating Air/Fuel Valve and Burner: The boiler burner shall be capable of a 15 to 1 turndown ratio of the firing rate without loss of combustion efficiency or staging of gas valves. The burner shall be fibre mesh design, with spark ignition and flame rectification. All burner material exposed to the combustion zone shall be of stainless steel construction.

**WASHINGTON MIDDLE SCHOOL
BOILER REPLACEMENT
1225 N BROAD STREET, MERIDEN CT 06450**

There shall be no moving parts within the burner itself. A modulating air/fuel, valve shall meter the air and natural gas input. The modulating motor must be linked to both the gas valve body and air valve body with a single linkage. The linkage shall not require any field adjustment.

- J. Pressure Vessel/Heat Exchanger The boiler shall be capable of handling return water temperatures down to 40 F without any failure due to thermal shock or fireside condensation. The heat exchanger shall be ASME stamped for a working pressure not less than 150 psig. The pressure vessel shall have a maximum water volume of 55 gallons. The boiler water pressure drop shall not exceed 4.0psig at 500gpm. The boiler water connections shall be 4" flanged 150 lb. ANSI rated. The pressure vessel is to be constructed of SA53 carbon steel, with a 0.25 in. thick wall and 0.50 in. thick upper head. Inspection openings in the pressure vessel shall be in accordance with ASME Section IV pressure vessel code.

The boiler shall be designed so that the thermal efficiency increases as the boiler firing rate decreases. The heat exchanger shall be constructed of 316L stainless steel fire tubes and tube sheets with a one-pass combustion gas flow design. The fire tubes shall be 5/8 in. OD with no less than 0.065 in. wall thickness. The upper and lower stainless steel tubesheet shall be no less than 0.313 in. thick. The pressure vessel/heat exchanger shall be welded construction. Access to the tubesheets and heat exchanger shall be available by burner and exhaust manifold removal. Minimum access opening shall be no less than 13.5 in. diameter.

Exchanger shall incorporate a fire tube design that will be self-supporting, baffle free, and warranted to withstand thermal shock under any flow condition primary to the main heating system. Both primary and secondary heat exchangers shall be ASME stamped for a working pressure not less than 150 psig. Unit shall have an ASME approved relief valve with a setting of 30 psig. Boiler supply and return connections shall not be less than 4" flanged to accommodate water flow through each boiler.

- K. Exhaust manifold shall be of cast aluminum, with an 8" diameter flue connection. Exhaust manifold shall have a gravity drain for the elimination of condensation with cast aluminum float style trap. Contractor shall be responsible for piping all boiler relief discharges and boiler condensate drains into a suitable removal header. Individual connections shall be indirect to allow gravity flow to drain point.
- L. Boiler plant piping shall be field constructed of materials as specified. Each boiler shall have individual isolating shutoff valves for service and maintenance. Each boiler shall require a minimum gas pressure of 4-10" W.C. (FM gas train) at 3,000 scfh. Gas vents shall be run outdoors.
- M. ASME Safety Controls Each boiler shall incorporate an electric probe type low water cutoff, automatic reset high limit, and a manual reset high limit safety device in accordance with ASME Section IV and CSD-1. Remote fault alarm contacts, sensor failure detection, and auxiliary contacts shall be standard equipment.
- N. Boiler Controls: The boiler integral control system shall be segregated into three components: "C-More" Control Panel, Power Box, and Input/Output Connection Box. The entire system shall be Underwriters Laboratories Recognized. The "C-More" control panel shall consist of 6 individual circuit boards utilizing state-of-the-art surface-mount technology in a single enclosure. These circuit boards shall be defined as follows:

**WASHINGTON MIDDLE SCHOOL
BOILER REPLACEMENT
1225 N BROAD STREET, MERIDEN CT 06450**

Display board incorporating LED display to read temperature
LCD display module for all message annunciation
CPU board which houses all control functions
Electric low water cutoff board with test and manual reset functions
Power supply board
Ignition /Stepper board incorporating flame safeguard control

Each board shall be individually field replaceable. The combustion safeguard/flame monitoring system shall utilize spark ignition and a rectification type flame sensor. The control panel hardware shall support both RS-232 and RS485 remote communications. The controls shall annunciate boiler & sensor status and include extensive self-diagnostic capabilities that incorporate a minimum of 8 separate status messages and 34 separate fault messages.

The "C-More" control panel shall incorporate three self-governing features designed to enhance operation in modes where it receives an external control signal by eliminating nuisance faults due to over-temperature, improper external signal or loss of external signal. These features shall be called: Setpoint High Limit, Setpoint Low Limit and Failsafe Mode. Setpoint High Limit allows for a selectable maximum boiler outlet temperature and acts as temperature limiting governor. It is a PID function that automatically limits firing rate to maintain outlet temperature within a 0 to 10 degree selectable band from the desired maximum boiler outlet temperature. Setpoint Low Limit allows for a selectable minimum operating temperature. Failsafe Mode allows the boiler to switch its mode to operate from an internal setpoint if its external control signal is lost, rather than shut off. This is a selectable mode; hence the control can be set to shut off the unit upon loss of external signal if so desired.

The boiler control system shall incorporate the following additional features for enhanced external system interface: system start temperature feature; pump delay timer; auxiliary start delay timer; auxiliary temperature sensor; mA output feature which allows for simple monitoring of temperature setpoint, outlet temperature, or fire rate; remote interlock circuit; delayed interlock circuit; and fault relay for simple remote fault alarm.

Each boiler shall utilize an electric single seated safety shutoff valve with proof of closure switch in its gas train and incorporate dual over-temperature protection with manual reset in accordance with ASME Section IV and CSD-1.

- O. Temperature Control Mode - Boiler shall include direct drive integral factory wired operating controls to control all operation and energy input of the boiler. The controller shall have the ability to vary boiler input throughout its full range to maximize the condensing capability of the boiler without header temperature swings.

The boiler will operate to vary the boiler firing rate linearly as an externally applied 4ma to 20ma signal is supplied. Unit shall operate with an inverse Efficiency Curve, with known Part Load Value Efficiencies. Maximum efficiency shall be achieved at minimum firing input. The boiler shall have LCD display for monitoring of all sensors and interlocks.

- P. Boiler Management System - Boiler manufacturer shall supply as part of boiler package a completely integrated AERCO Boiler Management System Model 168 to control all operation and energy input of the multiple boiler plant. The system shall be comprised of a

**WASHINGTON MIDDLE SCHOOL
BOILER REPLACEMENT
1225 N BROAD STREET, MERIDEN CT 06450**

microprocessor based control utilizing pulse width modulation for bumpless transfer of header temperature and sequential firing.

The controller shall have the ability to vary each individual module input throughout its full range to maximize the condensing capability of the module and the entire plant without header temperature swings. The controller shall be PID type for accurate temperature control with excellent frequency response. BMS shall provide contact closure for automatic adjustable heat start circuit for plant activation and have contact closure for auxiliary equipment such as pumps and combustion air dampers.

The BMS will operate on an adjustable inverse ratio in response to outdoor temperature to control the main header temperature outlet to +/- 2F. Units shall operate with an Inverse Efficiency Curve, with known Part Load Value Efficiencies. Maximum efficiency shall be achieved at minimum firing input. Control setpoints and ratio shall be fully field adjustable from 0.3 to 3.0 in operation. The controller shall have LCD display for monitoring of all sensors and interlocks. Non-volatile backup of all control setpoints shall be internally provided as standard with a communication interface for monitoring by building management computer. Control will automatically balance operating time on each module by a first on-first off mode and provide for setback and remote alarm contacts.

Boiler Model 168 shall interface with the Building Management System through a RS232 wiring port and Modbus communication. Communication shall be a two way monitoring and read/write registers as detailed in control specification. Connection between central BMS system and individual modules shall be through RS-485 connection port with daisy chained field wiring. All low voltage wiring shall be twisted pair low voltage field wiring to CMore control box terminal strips. All programming and hardware necessary to communicate both BAS system shall be supplied and provided by ATC contractor.

- Q. Exhaust Venting and Combustion Air - All aspects of installation of Boiler Plant shall be in strict accordance with manufacturer's instructions. Contractor shall submit on a complete exhaust venting system for the boiler plant as shown on the plans. Materials shall conform to all manufacturers' recommendations and shall be constructed of AL-29-4C Stainless Steel Positive Pressure U/L 1738 Listed Vent System. Venting shall be the responsibility of the installing Contractor.

Combustion air shall be fitted with field supplied materials as shown on the plans. Ducted combustion air shall be sized in accordance with the boiler manufacturers' instructions. Contractor shall coordinate with all other trades before installing supply and discharge vent piping.

- R. Spares - A spare set of ignitors and flame detectors shall be supplied for each boiler. Spares shall be turned over to the Meriden Public Schools's representative during building commissioning. Any other planned maintenance consumables or special tools required must be included in each spare set.
- S. Warranty - The water pressure vessel of boiler shall carry an unconditional 10 year warranty against leakage due to defective materials or workmanship. Manufacturer shall specifically warrantee heat exchanger from corrosion due to low temperature operation. The heat exchanger tubes/combustion chamber assembly shall be warranted against failure due to thermal stress failure or internal corrosion for a ten year period. A Warranty Certificate

**WASHINGTON MIDDLE SCHOOL
BOILER REPLACEMENT
1225 N BROAD STREET, MERIDEN CT 06450**

must be issued to the Meriden Public Schools from the manufacturer and a copy of warranty be submitted for engineers approval.

- T. Field Services - Contractor shall provide the services of a local factory authorized representative to supervise all phases of equipment startup. A letter of compliance with all factory recommendations and installation instructions shall be submitted to the engineer with operation and maintenance instructions.

Contractor shall provide the services of a licensed combustion technician to field adjust all boilers at full and partial load as recommended by the manufacturer. Combustion readings shall be recorded and included in the Meriden Public School's final documentation on the boiler plant

PART 3 -EXECUTION

3.1 INSTALLATION:

- A. Furnish and install the hot water piping as shown on plans and required for a complete installation. Furnish and install all control valves, flow valves, air vents, gate valves and/or balancing valves and drain valves.
- B. Provide hot water shutoff valves and combination shutoff and balancing cock for all equipment, hose cocks and drain valves at all low points. Provide air vents on all air handling equipment where they are required for proper operation of the system. Furnish and install balancing cocks on return flow of each and air handling unit.
- C. All piping work shall be installed with proper provision to allow for expansion and contraction of lines so as to prevent any undue strains on pipe and fittings, any trapping of lines or lifting or dislocating of any appliances.

Rectify without cost to the City of Meriden any conditions of noisy circulation due to trapped or air bound lines, including the expense of cutting and repairing of the building structure incident to making such alterations.

- F. Install the work to conform to space conditions and the work of other trades. The drawings indicate generally the runs and sizes of piping and, although the size must not be decreased, nor the drawings deviated from, except as unforeseen space conditions may require, the right is reversed to make minor changes in the arrangement of the work to meet conditions arising during construction.

3.2 TESTING:

- A. All flow piping shall be tested and made tight.
- B. All piping, including hot water piping, shall be tested and made tight at 100 psi or 50 psi above the city pressure before any piping is concealed or approved.
- C. After the system is thoroughly cleaned, it shall be put into operation by this Contractor. All parts of the system shall be thoroughly tested and this Contractor shall carefully instruct the

**WASHINGTON MIDDLE SCHOOL
BOILER REPLACEMENT
1225 N BROAD STREET, MERIDEN CT 06450**

City of Meriden authorized representative as to the proper operation and are of the entire system.

- D. All low pressure piping shall be tested and made tight at 100 lbs. per square inch hydrostatic pressure before any piping is concealed or covered.

3.3 BALANCING AND VENTING OF HOT WATER SYSTEM:

- A. Contractor shall provide all labor and materials as required to assist the Balancing Contractor in proper balancing of the water systems. Contractor shall return to the job and shall make necessary adjustments and corrections to the systems as required by the Balancing Contractor in order to achieve satisfactory system performance in accordance with design parameters.
- B. Contractor shall carefully vent the system when filling same and return to the job during the eighteen months guarantee period as required to assure the City of Meriden of a proper operating system.
- C. System shall be slowly filled with cold water to purge air and shall maintain 4 psig on a gauge located conveniently near the top of the system.

END OF SECTION 23 50 00

**WASHINGTON MIDDLE SCHOOL
BOILER REPLACEMENT
1225 N BROAD STREET, MERIDEN CT 06450**

SECTION 23 51 33 - BREECHINGS, CHIMNEY, AND STACKS FOR CONDENSING APPLIANCES

PART 1 - GENERAL

1.1 RELATED DOCUMENTS:

- A. The General Provisions of the Contract, including General and Supplementary Conditions and General Requirements, apply to the work specified in this Section.
- B. The General Requirements in Section 200050 shall also govern the work under this Section.
- C. Examine all drawings and data and coordinate the work of this Section with all related and adjoining work.

1.2 SUMMARY

- A. Section Includes:
 - 1. Venting for the removal of products of combustion for Category II, III, IV gas burning appliances

1.3 REFERENCES

- A. Underwriters Laboratories (UL):
 - 1. UL1738
- B. National Fire Protection Association (NFPA):
 - 1. NFPA 54 – National Fuel Gas Code

1.4 QUALITY ASSURANCE

- A. Comply with NFPA 54
- B. Must install duct in accordance to manufacturer's listings and installation instructions.
- C. Components coming in contact with the products of combustion shall carry the appropriate UL or cUL listing, mark or label.

1.5 WARRANTY

- A. Condensing Appliance vent listed to UL1738 shall have a limited lifetime warranty to begin at the date of installation. Any portion of the vent repaired or replaced under warranty shall be warranted for the remainder of the original warranty period.

PART 2- PRODUCTS

2.1 AVAILABLE MANUFACTURERS

- A. Listed Double-Wall vent for condensing appliances, as manufactured by Metal-Fab, Inc.

2.2 LISTED VENTING FOR CONDENSING APPLIANCES

- A. The condensing appliance vent shall be double-wall for use with Category II natural draft appliances and Category III or IV positive pressure appliances.
- B. Maximum temperature shall not exceed 550° F (288° C).
- C. Vent shall be listed for an internal static pressure of 6" w.g. and tested to 15" w.g. for diameters 6-36 inches and 10" w.g. for diameters 3-5.
- D. Vent shall be constructed of a material tested to UL1738, .015 thickness for 3"-12" diameters, .024 thickness for 14" to 24" diameters, and .035 thickness for 26" to 36" diameters.
- E. Outer casing shall be constructed of aluminized steel, type 430, 304, 316 stainless steel of .018 thickness for 3"to 12" diameters, .024 thickness for 14" to 24" diameters, and .035 thickness for 26" to 36" diameters.

PART 3 - EXECUTION

3.1 STORAGE AND CONSTRUCTION

- A. Protect materials from accidental damage.
- B. All supports, roof or wall penetrations, terminations, appliance connectors and drain fittings required to install the vent system shall be included.
- C. Joint assembly utilizes flanged mating surfaces with a factory supplied gaskets for diameters 6" through 24", for diameters 26" to 36" P070 sealant will be used on the flange surface. Flanges are joined with a vee band secured by tightening draw bolts. Diameters 3-5 inch utilize a snap-lock, gasketed connection.
- D. Where exposed to weather, the outer closure band shall be sealed to prevent moisture from entering the space between the walls.
- E. All parts exposed to the weather shall be protected by one (1) coat of corrosion and heat resistant base primer and one (1) coat of heat resistant paint unless constructed of 430, 304 or 316 stainless steel.
- F. Vent shall terminate in accordance with installation instructions and local codes.
- G. Installation shall conform to manufacturers installation instructions.

END OF SECTION 23 51 33

PART 1 - GENERAL

1.1 RELATED DOCUMENTS:

- A. The General Provisions of the Contract, including General and Supplementary Conditions and Division 1, General Requirements, apply to the work specified in this Section.
- B. Section 260000, General Electrical, shall govern the work under all Sections of Division 26.

1.2 DESCRIPTION:

- A. Work Included: The electrical work shall consist of all labor, equipment and services required to complete, ready for correct operation, all of the work called for by the accompanying drawings and these specifications.
- B. The work shall include, but is not limited to:
 - 1. Demolition.
 - 2. Raceways and Boxes.
 - 3. Branch Circuit Wiring.
 - 4. Wiring Devices.
 - 5. Circuit Breakers.

1.3 SITE CONDITIONS:

- A. Prior to submitting bid, visit the site and identify existing conditions and difficulties that will affect work called for by the Contract Documents.
- B. No compensation will be granted for additional work caused by unfamiliarity with site conditions that are visible or readily construed by experienced observers. Include in the bid amount all demolition work required.
- C. The Contractor shall verify and obtain all necessary dimensions at the site.

1.4 DEFINITIONS:

- A. Furnish: The word "furnish" is used to mean "supply and deliver the referenced item to the project site, ready for unloading, unpacking, assembly, and installation".
- B. Install: The word "install" is used to describe operations at the project site involving the referenced item including the actual "unloading, unpacking, assembly, erection, placing, anchoring, applying, working to dimension, finishing, curing, protecting, cleaning, and similar operations".
- C. Normally Occupied: The words "normally occupied" are used to mean "all rooms within a building except for crawlspaces, underground tunnels, attic spaces, mechanical rooms, telephone rooms, data distribution rooms, and electrical rooms".

**WASHINGTON MIDDLE SCHOOL
BOILER REPLACEMENT
1225 N BROAD STREET, MERIDEN CT 06450**

- D. Or Approved Equal: The words "or approved equal" are used to mean "any product which in the opinion of the Engineer is essentially equal in quality, size, arrangement, appearance, construction, and performance to that product specified or shown on the drawings".
- E. Provide: The word "provide" means "to furnish and install the referenced item, complete and ready for the intended use".
- F. Remove: The word "remove" means "to disconnect from its present position, remove from the project site, and to dispose of in a legal manner".

1.5 QUALITY ASSURANCE:

A. Codes and Standards

- 1. All work under this section shall comply with the applicable requirements of the National Electrical Code, local electrical and other codes, laws, regulations and standards including those of all state authorities. Where references are made in laws codes regulation and standards, these documents, including the latest revisions and amendments in effect as of the date of bid opening, shall form part of these specifications. Upon completion of the work, the contractor shall furnish Certificates of Approval from the local inspection authorities having jurisdiction for approving materials, equipment, installation pertaining to the electrical work as may be required by the local and/or state authority for the issuance of a permanent Certificate of Occupancy. All expenses arising from the procurement of these Certifications shall be paid by the contractor and shall be included in the lump sum contract price.
- 2. Codes enforced at time of bidding include: 2022 Connecticut State Building Code, 2021 IBC, 2022 Connecticut Fire Safety Code, 2020 National Electrical Code, ICC/ANSI A117.1-2017, Accessible and Usable Buildings and Facilities, ADA, and 2021 International Energy Conservation Code (IECC).

B. Submittals

- 1. The contractor shall submit for approval a complete list of materials, fixtures and equipment to be incorporated in the work. The list shall include manufacturer's names and catalog numbers, descriptive data, manufacturer's ratings and application recommendations, cuts, diagrams, performance curves and such other information as may be required by the City of Meriden to judge compliance with the requirements of the contract and suitability to the application. Items on the list shall be clearly identified as to proposed application. Approval of materials and equipment will be based on manufacturer's published ratings. Submittal procedures shall be in accordance with Division 1 of these specifications.
- 2. When directed by the City of Meriden, the contractor shall submit in approved form for record, a Certificate of Compliance with a cited code or standard for the designated materials and equipment; such certificates may be accepted in lieu of samples. Any materials or equipment submitted for approval, which are not in accordance with the specifications requirements may be rejected.
- 3. As part of the coordination work required of the contractor, installation drawings shall be prepared by the contractor as necessary. It is intended that these drawings be used to

**WASHINGTON MIDDLE SCHOOL
BOILER REPLACEMENT
1225 N BROAD STREET, MERIDEN CT 06450**

coordinate the work of the various trades and to clarify details of proposed assembly, erection and installation. Installation drawings shall be prepared when indicated in these specifications or on the electrical drawings, or when directed by the City of Meriden for comment or approval when an installation condition or problem arises which the contractor wishes the City of Meriden to review. All installation drawings submitted for review will be considered and treated as shop drawings and the requirements pertaining to shop drawings shall govern.

C. Equipment alternates, substitutions, and deviations:

1. Wherever more than one manufacturer is mentioned in the specifications or on the drawings, any of those named shall be considered equally acceptable to that on upon which design was based, and providing all aspects of the specification are met insofar as quality, construction, performance, space requirements, noise levels and special accessories or materials, any of those named may be included in Contractor's bid.
2. Bidders wishing to obtain approval on brands other than those specified by name shall submit their request to the Engineer not less than ten (10) business days before the date fixed for opening of bids. Approval by the Engineer will be in the form of an Addendum to the specifications issued to all prospective bidders, indicating that the additional brand or brands are approved as equal to those specified so far as the requirements of the project are concerned.
3. Wherever a single manufacturer is used in the specifications or on the drawings and is followed by the words "or approved equal" the Contractor must use the item named or he may apply for an alternate equipment deviation.
4. Alternate equipment to that specified or shown on the drawings, as proposed to be provided by the contractor, must be essentially equal in quality, size, construction, and performance to that item specified or shown on the drawings.
5. Submittals for alternate equipment shall list all deviations and differences from the specified equipment. Failure to submit this list will result in rejection of the submittal.

Any deviations and differences not listed but discovered after installation shall be rectified as directed by the Engineer at the Contractor's cost.

6. Furnish samples of alternate equipment proposed to be provided when so requested by the Engineer.
7. Where the Contractor proposes to use an item of equipment which differs from that upon which design was based, which requires any redesign of the structure, partitions, foundations, piping, wiring or of any other part of Mechanical, Electrical Layout, all such redesign, new drawings or detailing required shall be prepared by Contractor at his own expense for approval of the Engineer.
8. Where approved substitutions or deviations require a different quantity, size or arrangement of structural supports, wiring, conduit, piping, ductwork, and equipment from that upon which design was based, all additional items required by the systems shall, with the approval of the Engineer, be furnished by Contractor at no additional cost to The City of Meriden.

**WASHINGTON MIDDLE SCHOOL
BOILER REPLACEMENT
1225 N BROAD STREET, MERIDEN CT 06450**

- D. Allow sufficient time so that the delivery and installation of equipment will not be delayed as a result of the time required to review, process and transmit submittals, including resubmittals. Failure by the Contractor to transmit submittals to the Engineer in ample time for review and processing shall not entitle him to an extension of the Contract Time and no claim for an extension of time by reason of such default will be allowed.
- E. Submittals, shop drawings, and samples will be reviewed with reasonable promptness and will be stamped indicating appropriate action as follows:
1. "No Exceptions Taken" means that fabrication, manufacture, or construction may proceed providing submittal complies with contract documents.
 2. "Amend as Noted" means that fabrication, manufacture, or construction may proceed, providing the submittal complies with Engineer's notations and contract documents.
 3. "Resubmit" means that submittal, or equipment proposed to be provided, does not comply fully with the contract documents and that fabrication, manufacture, or construction shall not proceed. Resubmit in accordance with the Engineer's notations and contract documents.
 4. "Rejected" means that submittal does not comply with contract documents, or that equipment proposed to be provided does not comply with the specified requirements or is not equal or better in quality and performance than that item specified. Fabrication, manufacture, or construction shall not proceed. Resubmit in accordance with the contract documents and specified requirements.
- F. If material or equipment is installed prior to review, or without review, it shall be removed and replaced at no extra charge to the City of Meriden if, in the opinion of the Engineer, the material or equipment is not in compliance with the Contract Documents.
- G. Record Drawings
1. The contractor shall maintain an accurate record of all deviations in work as actually installed from work as indicated. This record shall be kept current and shall be kept available at the site for inspection. Upon completion of the work, and before final payment is authorized, marked prints with signed certifications of accuracy shall be delivered to the engineer.
- H. Manuals
1. The contractor shall furnish to the City of Meriden operating and maintenance instructions for each piece of equipment and each device.
 2. The instructions shall provide detailed descriptions of the operation and maintenance of the equipment or device and shall include manufacturer's literature, detailed wiring diagrams, device internal wiring diagrams, characteristics curves and graphs, data sheets and descriptive literature. The instructions shall be furnished to the City of Meriden 30 days prior to the completion of the building work.
- I. Product Handling
1. All work, materials and equipment, whether incorporated into the building or not, shall be protected from damage due to moisture, dirt, plaster, concrete, or from carelessness.

**WASHINGTON MIDDLE SCHOOL
BOILER REPLACEMENT
1225 N BROAD STREET, MERIDEN CT 06450**

2. All material and equipment which is damaged, including installed work, shall be repaired or replaced to the satisfaction of the City of Meriden.
3. After work is complete, all equipment, including switchboards, transformers, panelboards, lighting fixtures and lamps, shall be cleaned of all construction dirt.

1.6 INTENT OF SPECIFICATIONS:

- A. It is the intent of these Specifications each subcontractor or equipment suppliers to furnish all equipment complete with all motors, drives and magnetic starters throughout for all equipment furnished under these specifications. The above shall also apply to any additions to this Contract, either as covered by and Addenda or Change Orders.
- B. The Electrical Contractor shall provide overload and short circuit protection for all motors unless provided by equipment supplier for packaged type equipment.

1.7 GUARANTEE FOR EQUIPMENT AND SYSTEMS:

- A. Refer to Specifications.
- B. The entire Electrical System included under this Section of the Specifications shall be guaranteed by this Contractor against original defects of equipment and workmanship for a period of 12 months from date of acceptance, unless otherwise specified.

1.8 CUTTING AND PATCHING:

- A. Cutting and patching for all electrical work inside building shall be done in accordance with Division 1.

1.9 SLEEVES AND OPENINGS:

- A. This Electrical Contractor shall furnish and install all necessary sleeves and openings as required to permit the installation of the electrical systems.

1.10 ACCESS PANELS:

- A. Provide access panels to make all junction and pull boxes accessible as required by The National Electrical Code.

1.11 PAINTING:

- A. All painting of electrical work will be done in accordance with Division 9 unless otherwise specified.

1.12 RUBBISH AND CLEANING:

- A. This Contractor shall be responsible for removal of all rubbish and trash created by the installation of the electrical systems and equipment from the job site. Contractor shall sweep clean all areas.

1.14 INSTRUCTIONS:

**WASHINGTON MIDDLE SCHOOL
BOILER REPLACEMENT
1225 N BROAD STREET, MERIDEN CT 06450**

- A. The Superintendent of the electrical work for this particular project shall spend all necessary time required to instruct the custodians of the building, together with representatives from the Maintenance Department, in the installation including all special controls and devices installed or connected under this contract.

1.15 POWER SHUTDOWNS:

- A. Any power shutdown required for the completion of the electrical work shall be scheduled with the City of Meriden at least ten working days in advance and shall be done at The City of Meriden convenience.

1.17 SEISMIC:

- A. Provide seismic restraining devices on all required items of electrical equipment in accordance with the 2022 Connecticut State Building Code.

END OF SECTION 26 00 00

**WASHINGTON MIDDLE SCHOOL
BOILER REPLACEMENT
1225 N BROAD STREET, MERIDEN CT 06450**

SECTION 26 05 00

BASIC ELECTRICAL MATERIALS & METHODS

PART 1 - GENERAL

1.1 RELATED DOCUMENTS:

- A. The Bidding Requirements, Contract Forms and Conditions of the Contract, including General Conditions of the Contract for Construction, and Division 1 - General Requirements, apply to the work specified in this Section.
- B. Section 260000, General Electrical, shall also govern the work under this Section.
- C. This Section includes requirements that are binding on other Sections of Division 26.

1.2 SCOPE:

- A. Scope of work consists of installation of materials to be furnished under this Section, and without limiting generality thereof consists of furnishing labor, materials, equipment, hoisting, plant, transportation, rigging, staging, appurtenances, and services necessary and/or incidental to properly complete all electrical work as shown on the drawings, as described in these specifications or as reasonably inferred from either as being required in opinion of the City of Meriden.
- B. Work Included: Provide complete electrical services where shown on the drawings, as specified herein and as needed for a complete and proper installation including but not necessarily limited to:
 - 1. General
 - 2. Conduits & Raceways
 - 3. Identification
 - 4. Wire and Cables
 - 5. Wiring Devices
 - 6. Outlet Boxes, Junction Boxes, Pull Boxes
 - 7. Supporting Devices
 - 8. Disconnect Switches
 - 9. Grounding.
 - 10. Circuit Breakers.

1.3 QUALITY ASSURANCE:

- A. Refer to Section 260000.

1.4 SUBMITTALS:

- A. Shop Drawings: Submit for all items listed in Paragraph 1.2.B.

PART 2 - PRODUCTS

2.1 GENERAL:

**WASHINGTON MIDDLE SCHOOL
BOILER REPLACEMENT
1225 N BROAD STREET, MERIDEN CT 06450**

- A. Provide only materials that are new and of type and quality specified, or approved equal. Where Underwriters' Laboratories, Inc. has established standards for such materials, provide only materials bearing the UL label.
- B. Provide materials and equipment necessary to make installation complete in every detail, and to conform to manufacturers' latest installation instructions, under this contract whether or not specifically shown on drawings or specified herein.

2.2 TEMPORARY FACILITIES:

- A. Refer to the requirements of Division 1 regarding temporary facilities.
- B. Scaffolding and other temporary construction shall be rigidly built in accordance with Local and State requirements. Remove from premises upon completion of work.
- C. Provide temporary construction required for electrical work as directed by the City of Meriden.

2.3 RACEWAYS:

- A. Electrical Metallic Tubing:
 - 1. Shall be manufactured from high grade mild strip steel, shall be hot dipped galvanized, and shall be chromated and lacquered to form additional protective layer. EMT conduit shall conform to UL 797 and ANSI C80.3 and shall be as manufactured by Allied Tube and Conduit, or approved equal.
 - 2. Connectors and couplings shall be galvanized steel set screw type. Provide gland compression type couplings and connectors for exposed work in wet locations.
 - 3. Shall be used for all branch circuit wiring.
- B. Flexible Steel Conduit:
 - 1. Shall be manufactured from high grade strip steel and shall be hot dipped in a molten zinc bath. The steel strip shall be formed into interlocking convolutions that are continuously joined, metal to metal, assuring continuous grounding contact. Flexible steel conduit shall be UL listed and shall be as manufactured by AFC Cable Systems, or approved equal.
 - 2. May be used in short lengths where EMT cannot be installed due to interferences and obstacles.
 - 3. Provide for final connections to motor driven equipment or where subject to vibration.
- C. Liquid tight Flexible Steel Conduit:
 - 1. Shall be similar to flexible steel conduit, but with pressure-extruded moisture and oil-proof outer jacket of gray polyvinyl chloride plastic. Liquid tight flexible steel conduit shall be UL listed (UL 360) and shall be as manufactured by AFC Cable Systems, or approved equal.
 - 2. Fittings, couplings and connectors shall be hot dipped galvanized and threaded, liquid tight type.
 - 3. Provide where located outdoors or in damp or wet areas for final connections to motor driven equipment or where subject to vibration.

**WASHINGTON MIDDLE SCHOOL
BOILER REPLACEMENT
1225 N BROAD STREET, MERIDEN CT 06450**

2.4 IDENTIFICATION:

- A. Identify all junction boxes and pull boxes installed above ceilings and in unfinished spaces with branch circuit designations. Identification shall be done with black felt tip permanent marker in a neat and readily legible manner.

2.5 SAFETY SWITCHES:

- A. Furnish and install disconnect switches where shown on the drawings.

2.6 CONDUCTORS:

- A. All conductors shall be copper rated 600 volts, 90 deg. C., wet and dry locations, Type XHHW-2.
- B. Grounding electrode conductors and bonding conductors shall be soft drawn copper, ASTM B3 solid bare copper for sizes smaller than #8AWG, ASTM B8 stranded bare copper for sizes #8AWG and larger.
- C. Minimum gauge conductors for power and lighting shall be #12 AWG. Increase to #10 AWG for runs exceeding 75'-0", and #8AWG for runs exceeding 150'-0".
- D. Wire Size #8 AWG and larger shall be stranded. Wire of size smaller than #8 AWG shall be solid.
- E. Wire and cable conductors shall be soft drawn copper with conductivity of not less than 98 percent of ANSI Standard for annealed copper. Aluminum conductors shall not be used.

2.7 OUTLET, JUNCTION AND PULL BOXES:

- A. Provide outlet boxes as required for a complete installation.
- B. Outlet boxes shall be code gauge galvanized steel and shall be of shapes and sizes to suit their respective locations and installations, and shall be provided with covers to suite their function and installation. Outlet boxes shall be equipped with fixture stud or straps where required.
- C. The minimum box size for all wall outlet boxes shall be nominal 4" square x 2 1/8" deep (2-gang). Provide larger size outlet boxes, or gangable type boxes where required for the installation.
- D. For exposed work in normally unoccupied (unfinished) areas, provide pressed steel boxes with galvanized or cadmium plated steel covers with rounded corners. Provide cast boxes for work exposed to wet locations and where called for on the drawings.
- E. For above ground pull boxes, provide galvanized code-gauge sheet steel units with screwed on covers, of size and shape required to accommodate wires without crowding, and to suit the location. Provide pull boxes as specified herein, as required for job conditions, and as follows:
 - 1. Indoors: NEMA Type 1.
 - 2. Outdoors or Damp or Wet Locations: NEMA Type 3R.
 - 3. Hosedown and Splashing Water Locations: NEMA Type 4.

**WASHINGTON MIDDLE SCHOOL
BOILER REPLACEMENT
1225 N BROAD STREET, MERIDEN CT 06450**

- H. Wireways shall be code gauge galvanized steel, manufactured standard sections and fittings, with hinged and/or screw covers, indoors NEMA Type 1/Outdoors NEMA Type 3R. Wireways shall be sized to code conductor fill requirements and shall be provided as required for job conditions.

2.8 WIRING DEVICES:

- A. Provide the boiler emergency off switch with red cover plate where called for on the drawings.

2.9 CIRCUIT BREAKERS:

- A. Provide circuit breakers as noted on the drawings.

2.10 ACCESS PANELS:

- A. Provide access panels for electrical equipment and wiring splices which are not readily accessible. This includes electrical equipment and wiring splices installed above hung ceilings which are not readily removable, within walls, inside chases, or inside dead cavity spaces.
- B. Access panels shall be prime painted steel, with screwdriver lock, shall bear the same fire rating as the wall or ceiling in which they are installed, and shall be of sufficient size for wiring splice access or electrical equipment removal and replacement.

Access panels shall be provided in Milcor manufacturer , or approved equal. Provide Milcor Type A in acoustical tile surfaces, Type K for plastered surfaces, and Type M for masonry construction.

2.11 OTHER MATERIALS:

- A. Provide other materials, not specifically described but required for a complete and proper installation, as selected by the contractor subject to the approval of the engineer.

PART 3 - EXECUTION

3.1 GENERAL:

- A. Unless specifically noted or shown otherwise, install all equipment and material specified herein or shown on drawings whether or not specifically itemized herein. PART 3 covers particular installation methods and requirements peculiar to certain items and classes of materials and equipment.
- B. Examine the areas and conditions under which work of this Section will be performed. Correct conditions detrimental to timely and proper completion of the work. Do not proceed until satisfactory conditions are corrected.
- C. The electrical drawings are diagrammatic, but are required to be followed as closely as actual construction and work of other trades will permit. Where deviations are required to conform with actual construction and the work of the other trades, make such deviations without additional cost to the City of Meriden.
- D. Data indicated on the drawings and in these specifications are as exact as could be secured, but their absolute accuracy is not warranted. The exact locations, distances, levels and other

**WASHINGTON MIDDLE SCHOOL
BOILER REPLACEMENT
1225 N BROAD STREET, MERIDEN CT 06450**

conditions will be governed by actual construction and the drawings and specifications should be used only for guidance in such regard.

- E. Verify all measurements at the building. No extra compensation will be allowed because of differences between work shown on the drawings and actual measurements at the site of construction.
- F. Do not scale drawings. Scale indicated on drawings is for establishing reference points only. Actual field conditions shall govern all dimensions.
- G. Coordinate:
 - 1. Coordinate as necessary with other trades to assure proper and adequate provisions in the work of those trades for interface with the work of this Section.
 - 2. Coordinate delivery of electrical equipment to project prior to installation. Equipment stored for an extended period of time prior to installation may be subject to rejection by Engineer.
 - 3. Coordinate the installation of electrical items with the schedule for work of other trades to prevent unnecessary delays in the total work.
 - 4. Where electrical items are shown in conflict with locations of structural members and mechanical or other equipment, provide required supports and wiring to clear the encroachment.
 - 5. Arrange installation to provide access to equipment for easy maintenance and repair.

3.2 INSTALLATION OF RACEWAYS AND FITTINGS:

- A. Install wire and cable in approved raceways as specified and as approved by authorities having jurisdiction.
- B. All conduits shall be concealed from view above ceilings, in chases, and in walls. Conduits may only be installed exposed to view in mechanical and electrical rooms and where run overhead in rooms without ceilings.
- C. Run conduit and cable parallel to or at right angles with lines of the building, to present a neat appearance.
 - 1. Make bends with standard conduit elbows or conduit bent to not less than the same radius.
 - 2. Make bends free from dents and flattening.
- D. Provide code sized conduit unless a larger size is shown on the drawings or specified herein. Minimum size shall be ¾".
- E. Securely and rigidly support conduit throughout the work with approved conduit clips and hangers all in conformance with code seismic requirements.
 - 1. Do not use mechanics wire for supporting conduit.
 - 2. Do not support conduits on hung ceilings or from mechanical or electrical equipment.
 - 3. Steel supports and racks shall be galvanized steel channel and fittings, unistrut or approved equal.
 - 4. Provide clamps and support rods as required.

**WASHINGTON MIDDLE SCHOOL
BOILER REPLACEMENT
1225 N BROAD STREET, MERIDEN CT 06450**

5. Steel support rods or support bolts for conduits shall be 1/8 inch diameter for each inch or fraction thereof of diameter of conduit size, but no rod or bolt shall be less than 1/4" in diameter.
 6. Horizontal and vertical conduit supports shall not be more than 10' apart or more than 1' from any fitting.
- F. Do not install conduit runs exposed on the building exterior.
- G. Maintain at least 3" clearance between conduits and heating pipes when running parallel to these pipes, and at least 1" clearance when running perpendicular to these pipes.
- H. Provide double locknuts on all conduits terminating in sheet metal enclosures.
- I. Provide expansion couplings for rigid metallic and non-metallic conduits where such conduits are subject to thermal expansion and contraction.
- J. Provide full wall steel flexible conduit for all conduit penetrations through fire walls. Full wall steel flexible conduit shall be 3-hour through penetration fire wall rated and shall be as manufactured by AFC Cable Systems, or approved equal.
- K. Provide necessary sleeves and chases where conduits and cables pass through floors, walls, ceilings, and roofs, and provide other necessary openings and spaces, all arranged for in proper time to prevent unnecessary cutting. Perform cutting and patching in accordance with the provisions for the original work.
- L. Provide offsets prior to entrance into outlet boxes and other electrical equipment for proper adjustment to finished building surfaces.
- M. Seal around all conduit and cable penetrations through fire rated walls and ceilings with 3M Brand CP25N/S fire barrier caulking.
- N. Carefully clean and dry all conduit before installation of conductors. Plug conduit ends to exclude dust, moisture, plaster, or mortar while building is under construction. Lubricants or cleaning agents which might have deleterious effect on conductor coverings shall not be used for drawing conductors into raceways.
- O. All wiring shall be installed in electrical metallic tubing unless otherwise specified herein or called for on the drawings.

3.3 SLEEVES:

- A. Provide EMT sleeves for each conduit and cable passing through walls, partitions, and floors.
1. Set pipe sleeves in place before wall, floor, or partition is finished. Seal between sleeves and wall, partition, or floor.
 2. Support conduit and cable free from sleeves.
 3. Provide sleeves two pipe sizes larger than the conduit or cable passing through, or provide a minimum of 1/2" clearance.
- B. Caulk the space between sleeve and conduit or cable using 3M Brand OP25N/S fire barrier caulking.

**WASHINGTON MIDDLE SCHOOL
BOILER REPLACEMENT
1225 N BROAD STREET, MERIDEN CT 06450**

- C. Fireproof all penetrations made in fire rated walls or floors with UL approved materials to prevent passage of fire and smoke and maintain original fire rating of floors or walls.

3.4 CONDUCTOR INSTALLATION:

A. General:

- 1. The interior of all conduits shall be cleared of burrs, moisture, dirt and obstructions before wires are pulled.
- 2. Lubricant for pulling wires shall be inert to cable and conduit, shall not in any way restrict ease of pulling through conduit with passage of time, and shall be special lubricant designed specifically for cable pulling and shall be chemically compatible with cable.

B. Color Coding:

- 1. Consistent phase identification of all conductors shall be maintained as follows:

	<u>120/208V</u>
Phase A	Black
Phase B	Red
Phase C	Blue
Neutral Wire	White

Provide colored plastic tape of specified color code identification for large size conductors available only in black. Wrap tape three complete turns around conductor, at ends and at connections and splices. Provide same color coding for switch legs as corresponding phase conductor.

C. Minimum Conductor Sizes:

- 1. The minimum branch circuit conductor size shall be #12AWG. Provide #10AWG conductors for branch circuits where the conductor run exceeds 75 feet, and #8AWG conductors where the conductor run exceeds 150 feet.

- D. Provide the number of conductors required for a given branch circuit, or as required for circuitry, whether indicated on the drawings or not.

E. Neutral Conductors:

- 1. All branch circuits shall be installed with a separate neutral conductor. Shared neutrals for groups of branch circuits shall not be permitted.

- F. Provide each circuit with a dedicated ground wire. Use #12 minimum size.

- G. Identify conductors passing through pull boxes, junction boxes, and wireways to indicate circuit designation. Identify pull boxes and junction boxes as specified herein.

**WASHINGTON MIDDLE SCHOOL
BOILER REPLACEMENT
1225 N BROAD STREET, MERIDEN CT 06450**

- H. Branch circuit wiring and arrangement of home runs have been designed for maximum economy consistent with adequate sizing for voltage drops, circuit ampacities and other considerations.
 - 1. Install the wiring with circuits arranged as shown on the drawings, except as otherwise approved in advance by the Engineer.
 - 2. Do not make changes and rearrange circuits without prior approval.
 - 3. If more than 3 current carrying conductors are installed in one conduit they shall be derated in accordance with the National Electric Code.
 - 4. Do not install more than three 30 Amp single phase or four 20 Amp single phase circuits in the same conduit. Do not run emergency and normal power wiring in the same conduit.

- I. Splices and Connections:
 - 1. Makes splices electrically and mechanically secure with pressure-type connectors.
 - a. For wires size #8AWG and smaller, provide solderless, screw-on connectors, “Scotch-Lock” or equal, 600V rating, of size and type to manufacturer’s recommendation, with temperature ratings equal to the conductor insulation.
 - b. Make splices and terminations to conductors #6AWG and larger with corrosion-resistant, high conductivity, pressure indent, hex screw or bolt clamp connectors, with or without tongues, designed specifically for intended service.
 - 2. Insulate splices with a minimum of two layers of scotch brand No. 33 vinyl-plastic electrical tape where insulation is required.
 - 3. Tape joints as required with rubber tape 1 ½ times the thickness of the conductor insulation, then cover with the vinyl-plastic electrical tape specified above.
 - 4. Provide high conductivity copper alloy bolt-on lugs with pressure plate and socket set screw or hex head screw to attach wire and cable to disconnect switches, transformers, and other electrical equipment as required.

3.5 OUTLET BOXES:

- A. All outlet boxes in finished areas shall be concealed from view above hung ceilings or recessed (flush) in walls and floors. Outlet boxes may only be exposed to view or surface mount type in mechanical and electrical rooms, or for feeding items overhead in rooms without ceilings.

- C. Install outlet boxes at uniform heights and straight and true with reference to walls, floors, ceilings and casework.

- D. Provide knockout plugs in boxes with unused openings.

- E. Secure all outlet boxes to building structure with metal straps, rods, or bolts independently of entering conduits or cables.

- F. Provide bar hanger outlets in hollow framed partitions with bar hanger secured to partition studs with self-threading screws, or drill through hangers with Caddy or equal clips.

**WASHINGTON MIDDLE SCHOOL
BOILER REPLACEMENT
1225 N BROAD STREET, MERIDEN CT 06450**

- G. Provide horizontal separation for outlet boxes mounted on opposite sides of common wall. Back to back or thru-wall boxes will not be permitted.

3.6 PULL BOXES AND JUNCTION BOXES:

- A. Provide pull boxes and junction boxes where shown on the plans and where required to facilitate proper pulling of wires and cables. Install pull boxes or pull fittings no less than one every 100 ft. of straight horizontal conduit run, or three 90 degree bends, unless otherwise noted.

3.7 MOTOR POWER AND CONTROL WIRING:

- A. Contractor shall provide and be responsible for the complete power wiring of all motors and motorized equipment.
- B. Furnish proper overload and short circuit protection for all new motors. Provide a combination thermal overload and disconnect for switch all equipment using fractional horsepower motors.
- C. Check electrical connections and sizing of motor circuit protection and prevent damage to motor and equipment from incorrect direction of rotation.
- D. Provide mounting for motor and equipment disconnect switches adjacent to motor and supported independent of motor.
- E. Connections to miscellaneous building equipment:
 - 1. Wire to and connect to, all items of building equipment not specifically described in this Section but to which electrical power is required.
 - 2. Coordinate as necessary with other trades and suppliers to verify types, numbers and locations of equipment.

3.8 GROUNDING SYSTEM:

- A. Provide a complete grounding system which will thoroughly ground the non-current carrying metal parts of every piece of installed equipment, as described herein and as indicated on the drawings.
- B. System shall be mechanically and electrically connected to provide an independent return path to the grounding sources.
- C. Each grounding conductor shall have a minimum capacity of 25 percent of the rated capacity of the equipment it grounds, unless otherwise indicated.
- D. The minimum size of grounding conductors shall be No. 12 AWG copper. Insulation color of grounding conductors shall be green.
- E. Provide a separate green ground conductor for each branch circuit.

3.9 SPECIAL REQUIREMENTS:

**WASHINGTON MIDDLE SCHOOL
BOILER REPLACEMENT
1225 N BROAD STREET, MERIDEN CT 06450**

- A. Wiring shall be bundle tied where passing through pull boxes, wireways, and panelboards in neat and orderly manner with plastic cable ties. Cable ties shall be Ty-Raps as manufactured by Thomas & Betts, or equal.
- B. Provide miscellaneous hardware and support accessories, including Unistrut, channels, support rods, nuts, bolts, screws, and other such items, with galvanized or cadmium plated finish, or other approved rust inhibiting coatings.
- C. Unload electrical equipment and materials delivered to site. Pay cost for rigging, hoisting, lowering and moving electrical equipment on site, in building or on roof. During construction provide additional protection against moisture, dust accumulation and physical damage of electrical equipment. Provide temporary heaters within units, as approved to evaporate excessive moisture and provide ventilation as required.

3.10 TESTING AND INSPECTION:

- A. Provide personnel and equipment, make required tests, and secure required approvals from the Engineer and governmental agencies having jurisdiction.
- B. When material and/or workmanship is found to not comply with the specified requirements, within three days after receipt of notice of such non-compliance remove the non-complying items from the job site and replace them with items complying with the specified requirements, all at no additional cost to the City of Meriden.
- C. Perform all required adjustments and settings. Verify and correct deficiencies as necessary including voltages, tap settings, trip settings and phasing of equipment from distribution system to point of use.
- D. Provide all necessary testing equipment.
- E. In the City of Meriden Presence:
 - 1. Test all parts of the electrical system and prove that all such items provided under this Section function electrically in the required manner.

3.13 PROJECT COMPLETION:

- A. Upon completion of the work of this Section, thoroughly clean all exposed portions of the electrical installation, removing all traces of soil, labels, grease, oil and other foreign material, and using only the type cleaner recommended by the manufacturer of the item being cleaned.
- B. Equipment with damage to painted finish shall be repaired to satisfaction of the Engineer.
- C. On the first day the facility is in operation, for at least eight hours, at a time directed by the Owner, provide a qualified foreman and crew to perform such electrical work as may be required by the Owner.
- E. Thoroughly indoctrinate the City of Meriden's operation and maintenance personnel in the contents of the operations and maintenance manual required to be submitted under these Specifications.

3.14 EQUIPMENT SPECIFIED:

**WASHINGTON MIDDLE SCHOOL
BOILER REPLACEMENT
1225 N BROAD STREET, MERIDEN CT 06450**

- A. Contractor shall furnish equipment or systems in manufacturers specified or named herein or on the drawings. No other manufacturers shall be considered.

END OF SECTION 26 05 00

**WASHINGTON MIDDLE SCHOOL
BOILER REPLACEMENT
1225 N BROAD STREET, MERIDEN CT 06450**

SECTION 26 29 23 VARIABLE FREQUENCY DRIVES FOR HVAC APPLICATION

PART 1 - GENERAL

1.1 RELATED DOCUMENTS:

- A. The General Provisions of the Contract, including General and Supplementary Conditions and General Requirements, apply to the work specified in this Section.
- B. The General Requirements in Section 200050 shall also govern the work under this section.

1.2 DESCRIPTION

- A. This specification is to cover a complete Variable Frequency motor Drive (VFD) consisting of a pulse width modulated (PWM) inverter designed for use on a standard NEMA Design B induction motor.
- B. The drive manufacturer shall supply the drive and all necessary controls as herein specified. The manufacturer shall have been engaged in the production of this type of equipment for a minimum of twenty years. All VFDs installed on this project shall be from the same manufacturer.

1.3 QUALITY ASSURANCE

- A. Referenced Standards:
 - 1. Institute of Electrical and Electronic Engineers (IEEE)
 - a) Standard 519-1992, IEEE Guide for Harmonic Content and Control.
 - 2. Underwriters laboratories
 - a) UL508C
 - 3. National Electrical Manufacturer's Association (NEMA)
 - a) ICS 7.0, AC Adjustable Speed Drives
 - 4. IEC 16800 Parts 1 and 2
- B. Qualifications:
 - 1. VFDs and options shall be UL listed as a complete assembly. VFDs that require the customer to supply external fuses for the VFD to be UL listed are not acceptable. VFDs with requiring additional branch circuit protection are not acceptable. The base VFD shall be UL listed for 100 KAIC without the need for input fusing.
 - 2. CE Mark – The VFD shall conform to the European Union ElectroMagnetic Compatibility directive, a requirement for CE marking. The VFD shall meet product standard EN 61800-3 for the First Environment restricted level.
 - 3. Acceptable Manufactures:
 - a) ABB ACH580 Series

1.4 SUBMITTALS

- A. Submittals shall include the following information:
 - 1. Outline dimensions, conduit entry locations and weight.
 - 2. Customer connection and power wiring diagrams.

**WASHINGTON MIDDLE SCHOOL
BOILER REPLACEMENT
1225 N BROAD STREET, MERIDEN CT 06450**

3. Complete technical product description include a complete list of options provided. Any portions of the specifications not complied with must be clearly indicated or the supplier and contractor shall be liable to provide all components required to meet the specification.
4. Compliance to IEEE 519 – harmonic analysis for particular jobsite including total harmonic voltage distortion and total harmonic current distortion (TDD).
 - a) The VFD manufacturer shall provide calculations; specific to the installation, showing total harmonic voltage distortion is less than 5%. Input filters shall be sized and provided as required by the VFD manufacturer to ensure compliance with the IEEE electrical system standard 519. All VFDs shall include a minimum of 5% equivalent impedance reactors, no exceptions.

PART 2 – PRODUCTS

2.01 VARIABLE FREQUENCY DRIVES

- A. The VFD package as specified herein shall be enclosed in a UL Listed Type enclosure, (NEMA rated enclosures are not acceptable) completely assembled and tested by the manufacturer in an ISO9001 facility. The VFD tolerated voltage window shall allow the VFD to operate from a line of +30% nominal, and -35% nominal voltage as a minimum.
 1. Environmental operating conditions: 0 – 40° C continuous. Altitude 0 to 3300 feet above sea level, up to 95% humidity, non-condensing. All circuit boards shall have conformal coating.
 2. Enclosure shall be rated UL type 1 and shall be UL listed as a plenum rated VFD.
- B. All VFDs shall have the following features:
 1. All VFDs shall have the same customer interface, including digital display, and keypad, regardless of horsepower rating. The keypad shall be removable, capable of remote mounting and allow for uploading and downloading of parameter settings as an aid for start-up of multiple VFDs.
 2. The keypad shall include Hand-Off-Auto selections and manual speed control. There shall be fault reset and “Help” buttons on the keypad. The Help button shall include “on-line” assistance for programming and troubleshooting.
 3. There shall be a built-in time clock in the VFD keypad. The clock shall have a battery back up with 10 years minimum life span. The clock shall be used to date and time stamp faults and record operating parameters at the time of fault. If the battery fails, the VFD shall automatically revert to hours of operation since initial power up. The clock shall also be programmable to control start/stop functions, constant speeds, PID parameter sets and output relays. The VFD shall have a digital input that allows an override to the time clock (when in the off mode) for a programmable time frame. There shall be four (4) separate, independent timer functions that have both weekday and weekend settings. Capacitor backup is not acceptable.
 4. The VFD shall be capable of starting into a coasting load (forward or reverse) up to full speed and accelerate or decelerate to setpoint without safety tripping or component damage (flying start).

**WASHINGTON MIDDLE SCHOOL
BOILER REPLACEMENT
1225 N BROAD STREET, MERIDEN CT 06450**

5. The overload rating of the drive shall be 110% of its normal duty current rating for 1 minute every 10 minutes, 130% overload for 2 seconds. The minimum FLA rating shall meet or exceed the values in the NEC/UL table 430-150 for 4-pole motors.
 6. The VFD shall have 5% equivalent impedance internal reactors to reduce the harmonics to the power line and to add protection from AC line transients. The 5% equivalent impedance may be from dual (positive and negative DC bus) reactors, or 5% AC line reactors. VFDs with only one DC reactor shall add an AC line reactor.
 7. The VFD shall include a coordinated AC transient protection system consisting of 4-120 joule rated MOV's (phase to phase and phase to ground), a capacitor clamp, and 5% equivalent impedance internal reactors.
 8. The VFD shall provide a programmable proof of flow Form-C relay output (broken belt / broken coupling). The drive shall be programmable to signal this condition via a keypad warning, relay output and/or over the serial communications bus. Relay outputs shall include programmable time delays that will allow for drive acceleration from zero speed without signaling a false underload condition.
- D. All VFDs to have the following adjustments:
1. Three (3) programmable critical frequency lockout ranges to prevent the VFD from operating the load continuously at an unstable speed.
 2. Two (2) PID Setpoint controllers shall be standard in the drive, allowing pressure or flow signals to be connected to the VFD, using the microprocessor in the VFD for the closed loop control. The VFD shall have 250 ma of 24 VDC auxiliary power and be capable of loop powering a transmitter supplied by others. There shall be two parameter sets for the first PID that allow the sets to be switched via a digital input, serial communications or from the keypad for night setback, summer/winter setpoints, etc. There shall be an independent, second PID loop that can utilize the second analog input and modulate one of the analog outputs to maintain setpoint of an independent process (ie. valves, dampers, etc.). All setpoints, process variables, etc. to be accessible from the serial communication network.
 3. Two (2) programmable analog inputs shall accept current or voltage signals.
 4. Two (2) programmable analog outputs (0-20ma or 4-20 ma). The outputs may be programmed to output proportional to Frequency, Motor Speed, Output Voltage, Output Current, Motor Torque, Motor Power (kW), DC Bus voltage, Active Reference, and other data.
 5. Six (6) programmable digital inputs.
 6. Three (3) programmable digital Form-C relay outputs. The relays shall include programmable on and off delay times and adjustable hysteresis. The relays shall be rated for maximum switching current 8 amps at 24 VDC and 0.4 A at 250 VAC; Maximum voltage 300 VDC and 250 VAC; continuous current rating 2 amps RMS. Outputs shall be true Form-C type contacts; open collector outputs are not acceptable.
 7. Run permissive circuit - There shall be a run permissive circuit for damper or valve control. Regardless of the source of a run command (keypad, time-clock control, or serial communications) the VFD shall provide a dry contact closure that will signal the damper to open (VFD motor does not operate). When the damper is fully open, a normally open dry contact (end-switch) shall close. The closed end-switch is wired to a VFD digital input and allows motor

**WASHINGTON MIDDLE SCHOOL
BOILER REPLACEMENT
1225 N BROAD STREET, MERIDEN CT 06450**

- operation. Two separate safety interlock inputs shall be provided. When either safety is opened, the motor shall be commanded to coast to stop, and the damper shall be commanded to close.
8. Two independently adjustable accel and decel ramps with 1 – 1800 seconds adjustable time ramps.
 9. The VFD shall include a motor flux optimization circuit that will automatically reduce applied motor voltage to the motor to optimize energy consumption and audible motor noise.
 10. The VFD shall include a carrier frequency control circuit that reduces the carrier frequency based on actual VFD temperature that allows higher carrier frequency without derating the VFD or operating at high carrier frequency only at low speeds.
 11. The VFD shall include password protection against parameter changes.
- E. The Keypad shall include a backlit LCD display. The display shall be in complete English words for programming and fault diagnostics (LED and alpha-numeric codes are not acceptable). All VFD faults shall be displayed in English words.
- F. All applicable operating values shall be capable of being displayed in engineering (user) units. A minimum of three operating values from the list below shall be capable of being displayed at all times. The display shall be in complete English words (alpha-numeric codes are not acceptable):
- Output Frequency
 - Motor Speed (RPM, %, or Engineering units)
 - Motor Current
 - Drive Temperature
 - DC Bus Voltage
 - Output Voltage
- G. The VFD shall include a fireman’s override input. Upon receipt of a contact closure from the fireman’s control station, the VFD shall operate in one of two modes: 1) Operate at a programmed predetermined fixed speed or operate in a specific fireman’s override PID algorithm that automatically adjusts motor speed based on override set point and feedback . The mode shall override all other inputs (analog/digital, serial communication, and all keypad commands), except customer defined safety run interlock, and force the motor to run in one of the two modes above. “Override Mode” shall be displayed on the keypad. Upon removal of the override signal, the VFD shall resume normal operation.
- H. Serial Communications
1. The VFD shall have an RS-485 port as standard. The standard protocols shall be Modbus, BACnet, Johnson Controls N2 bus, and Siemens Building Technologies FLN. Each individual drive shall have the protocol in the base VFD. The use of third party gateways and multiplexers is not acceptable. All protocols shall be “certified” by the governing authority (i.e. BTL Listing for BACnet). Use of non-certified protocols is not allowed.
 2. The BACnet connection shall be an RS485, MS/TP interface operating at 9.6, 19.2, 38.4, or 76.8 Kbps. The connection shall be tested by the BACnet Testing Labs (BTL) and be BTL Listed. The BACnet interface shall conform

**WASHINGTON MIDDLE SCHOOL
BOILER REPLACEMENT
1225 N BROAD STREET, MERIDEN CT 06450**

- to the BACnet standard device type of an Applications Specific Controller (B-ASC). The interface shall support all BIBBs defined by the BACnet standard profile for a B-ASC including, but not limited to:
- a. Data Sharing – Read Property – B.
 - b. Data Sharing – Write Property – B.
 - c. Device Management – Dynamic Device Binding (Who-Is; I-AM).
 - d. Device Management – Dynamic Object Binding (Who-Has; I-Have).
 - e. Device Management – Communication Control – B.
3. Serial communication capabilities shall include, but not be limited to; run-stop control, speed set adjustment, proportional/integral/derivative PID control adjustments, current limit, accel/decel time adjustments, and lock and unlock the keypad. The drive shall have the capability of allowing the DDC to monitor feedback such as process variable feedback, output speed / frequency, current (in amps), % torque, power (kW), kilowatt hours (resettable), operating hours (resettable), and drive temperature. The DDC shall also be capable of monitoring the VFD relay output status, digital input status, and all analog input and analog output values. All diagnostic warning and fault information shall be transmitted over the serial communications bus. Remote VFD fault reset shall be possible.
- I. EMI / RFI filters. All VFDs shall include EMI/RFI filters. The VFD shall comply with standard EN 61800-3 for the First Environment, restricted level with up to 100' of motor cables. No Exceptions. Certified test lab test reports shall be provided with the submittals.
- J. All VFDs through 60HP shall be protected from input and output power miswiring. The VFD shall sense this condition and display an alarm on the keypad. The VFD shall not be damaged by this condition.
- K. OPTIONAL FEATURES – Optional features to be furnished and mounted by the drive manufacturer. All optional features shall be UL Listed by the drive manufacturer as a complete assembly and carry a UL508 label. The bypass enclosure door and VFD enclosure must be interlocked such that input power is turned off before either enclosure can be opened. The VFD and Bypass as a package shall have a UL listed short circuit rating of 100,000 amps and shall be indicated on the data label.
1. A complete factory wired and tested bypass system consisting of an output contactor and bypass contactor, service (isolation) switch and VFD input fuses are required. Bypass designs, which have no VFD only fuses, or that incorporate fuses common to both the VFD and the bypass will not be accepted
 2. Door interlocked padlockable circuit breaker that will disconnect all input power from the drive and all internally mounted options.
- L. The following operators shall be provided:
- a. Bypass Hand-Off-Auto
 - b. Drive mode selector and light
 - c. Bypass mode selector and light
 - d. Bypass fault reset

**WASHINGTON MIDDLE SCHOOL
BOILER REPLACEMENT
1225 N BROAD STREET, MERIDEN CT 06450**

- e. Bypass LDC display, 2 lines, for programming and status / fault / warning indications
1. Motor protection from single phase power conditions - The Bypass system must be able to detect a single phase input power condition while running in bypass, disengage the motor in a controlled fashion, and give a single phase input power indication. Bypass systems not incorporating single phase protection in Bypass mode are not acceptable.
 2. The system (VFD and Bypass) tolerated voltage window shall allow the system to operate from a line of +30%, -35% nominal voltage as a minimum. The system shall incorporate circuitry that will allow the drive or bypass contactor to remain “sealed in” over this voltage tolerance at a minimum.
 3. The Bypass system shall NOT depend on the VFD for bypass operation. The bypass shall be completely functional in both Hand and Automatic modes even if the VFD has been removed from the enclosure for repair / replacement.
 4. Serial communications – the bypass and VFD shall be capable of being monitored and or controlled via serial communications. Provide communications protocols for ModBus; Johnson Controls N2; Siemens Building Technologies FLN (P1) and BACnet in the bypass controller.
 5. BACnet Serial communication bypass capabilities shall include, but not be limited to; bypass run-stop control; the ability to force the unit to bypass; and the ability to lock and unlock the keypad. The bypass shall have the capability of allowing the DDC to monitor feedback such as, bypass current (in amps), bypass kilowatt hours (resettable), bypass operating hours (resettable), and bypass logic board temperature. The DDC shall also be capable of monitoring the bypass relays output status, and all digital input status. All bypass diagnostic warning and fault information shall be transmitted over the serial communications bus. Remote bypass fault reset shall be possible. The following additional bypass status indications and settings shall be transmitted over the serial communications bus – keypad “Hand” or “Auto” selected, and bypass selected. The DDC system shall also be able to monitor if the motor is running under load in both VFD and bypass (proof of flow) in the VFD mode over serial communications or Form-C relay output. A minimum of 40 field parameters shall be capable of being monitored in the bypass mode.
 6. Run permissive circuit - there shall be a run permissive circuit for damper or valve control. Regardless of the source of a run command (keypad, time-clock control, or serial communications) the VFD and bypass shall provide a dry contact closure that will signal the damper to open (VFD motor does not operate). When the damper is fully open, a normally open dry contact (end-switch) shall close. The closed end-switch is wired to a VFD system input and allows motor operation. Two separate safety interlock inputs shall be provided. When either safety is opened, the motor shall be commanded to coast to stop, and the damper shall be commanded to close.
 7. The bypass control shall monitor the status of the VFD and bypass contactors and indicate when there is a welded contactor contact or open contactor coil. This failed contactor operation shall be indicated on the Bypass LCD display as well as over the serial communications protocol.
 8. The bypass control shall include a programmable time delay for bypass start and keypad indication that this time delay is in process. This will allow

**WASHINGTON MIDDLE SCHOOL
BOILER REPLACEMENT
1225 N BROAD STREET, MERIDEN CT 06450**

- VAV boxes to be driven open before the motor operates at full speed in the bypass mode. The time delay shall be field programmable from 0 – 120 seconds.
9. The bypass control shall be programmable for manual or automatic transfer to bypass. The user shall be able to select via keypad programming which drive faults will generate an automatic transfer to bypass and which faults require a manual transfer to bypass.
 10. There shall be an adjustable motor current sensing circuit for the bypass and VFD mode to provide proof of flow indication. The condition shall be indicated on the keypad display, transmitted over the building automation protocol and on a relay output contact closure.
 11. The bypass controller shall have six programmable digital inputs, and five programmable Form-C relay outputs.
 12. The relay outputs from the bypass shall be programmable for any of the following indications.
 - a. System started
 - b. System running
 - c. Bypass override enabled
 - d. Drive fault
 - e. Bypass fault
 - f. Bypass H-O-A position
 - g. Motor proof of flow (broken belt)
 - h. Overload
 - i. Bypass selected
 - j. Bypass run
 - k. System started (damper opening)
 - l. Bypass alarm
 - m. Over temperature
 13. The digital inputs for the system shall accept 24VAC or 24VDC. The bypass shall incorporate internally sourced power supply and not require an external control power source. The bypass power board shall supply 250 ma of 24 VDC for use by others to power external devices.
 14. Customer Interlock Terminal Strip – provide a separate terminal strip for connection of freeze, fire, smoke contacts, and external start command. All external safety interlocks shall remain fully functional whether the system is in VFD or Bypass mode. The remote start/stop contact shall operate in VFD and bypass modes. The terminal strip shall allow for independent connection of up to four (4) unique safety inputs.
 15. The user shall be able to select the text to be displayed on the keypad when the safety opens. Example text display indications include “Firestat”, “Freezestat”, “Over pressure” and “Low pressure”. The user shall also be able to determine which of the four (4) safety contacts is open over the serial communications connection.
 16. Class 10, 20, or 30 (selectable) electronic motor overload protection shall be included.

PART 3 – EXECUTION

3.1 INSTALLATION

**WASHINGTON MIDDLE SCHOOL
BOILER REPLACEMENT
1225 N BROAD STREET, MERIDEN CT 06450**

- A. Installation shall be the responsibility of the mechanical contractor. The contractor shall install the drive in accordance with the requirements of the VFD manufacturer's installation manual.

3.2 START-UP

- A. Certified factory start-up shall be provided for each drive by a factory certified service center. A certified start-up form shall be filled out for each drive with a copy provided to the West Hartford Public Schools, and a copy kept on file at the manufacturer.

3.3 PRODUCT SUPPORT

- A. Factory trained application engineering and service personnel that are thoroughly familiar with the VFD products offered shall be locally available at both the specifying and installation locations. A toll free 24/365 technical support line shall be available.
- B. A computer based training CD or 8-hour professionally generated video (VCR format) shall be provided to the West Hartford Public Schools at the time of project closeout. The training shall include installation, programming and operation of the VFD, bypass and serial communication.

3.4 WARRANTY

- A. Warranty shall be 24 months from the date of certified start-up, not to exceed 30 months from the date of shipment. The warranty shall include all parts, labor, travel time and expenses.

END OF SECTION 26 29 23

LIST OF DRAWINGS

- COVER
- M0.1 BOILER ROOM PART PLAN – MECHANICAL DEMOLITION and NEW WORK
- M0.2 MECHANICAL SCHEMATIC PIPING DIAGRAM, DETAILS and SCHEDULES
- M0.3 MECHANICAL DETAILS
- M1.1 1st FLOOR SECTION "A" – MECHANICAL DEMOLITION and NEW WORK
- M1.2 1st FLOOR SECTION "B" – MECHANICAL DEMOLITION and NEW WORK
- M2.1 2nd FLOOR SECTION "B" – MECHANICAL DEMOLITION and NEW WORK
- M3.1 MECHANICAL TEMPERATURE CONTROL DIAGRAMS

- EO.1 BOILER ROOM PART PLAN – ELECTRICAL DEMOLITION and NEW WORK

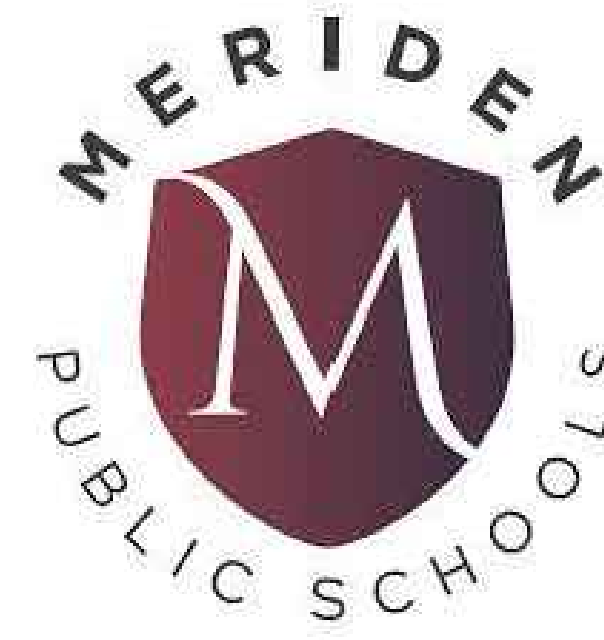

WASHINGTON MIDDLE SCHOOL

1225 N Broad Street
MERIDEN, CONNECTICUT 06450



BOILER REPLACEMENT AND TEMPERATURE CONTROL UPGRADES

M/E/P ENGINEER
BEMIS ASSOCIATES LLC
185 MAIN STREET
FARMINGTON, CONNECTICUT
Phone: 860-667-3233
Fax: 860-321-7070

© COPYRIGHT
This drawing is an instrument of service and shall remain the property of BEMIS ASSOCIATES, L.L.C. No part of this drawing may be reproduced or transmitted in any form or by any means, electronic or mechanical, including photocopying, recording, or by any information storage and retrieval system, without the express written approval of BEMIS ASSOCIATES, L.L.C.
Minimum or maximum dimensions shown on drawings are for informational purposes only. The contractor shall verify all dimensions and conditions of work in the field. Any discrepancy or deviation from the drawings shall be reported to the project manager immediately. The contractor shall be responsible for any and all costs incurred by the client as a result of any error or omission on the part of the contractor. Any adjustment or variation of the drawings of BEMIS ASSOCIATES, L.L.C. shall be approved by the client prior to construction.

WASHINGTON MIDDLE SCHOOL BOILER REPLACEMENT

MERIDEN, CONNECTICUT

BEMIS ASSOCIATES, L.L.C.
Consulting Engineers
185 Main Street
Farmington, CT 06032
Tel: (860) 321-7070
Fax: (860) 321-7070
www.bemisassociates.com

BA

TITLE
BOILER ROOM PART PLAN
MECHANICAL DEMOLITION AND NEW WORK

DATE 03/14/2024

DWG. NO.

M0.1

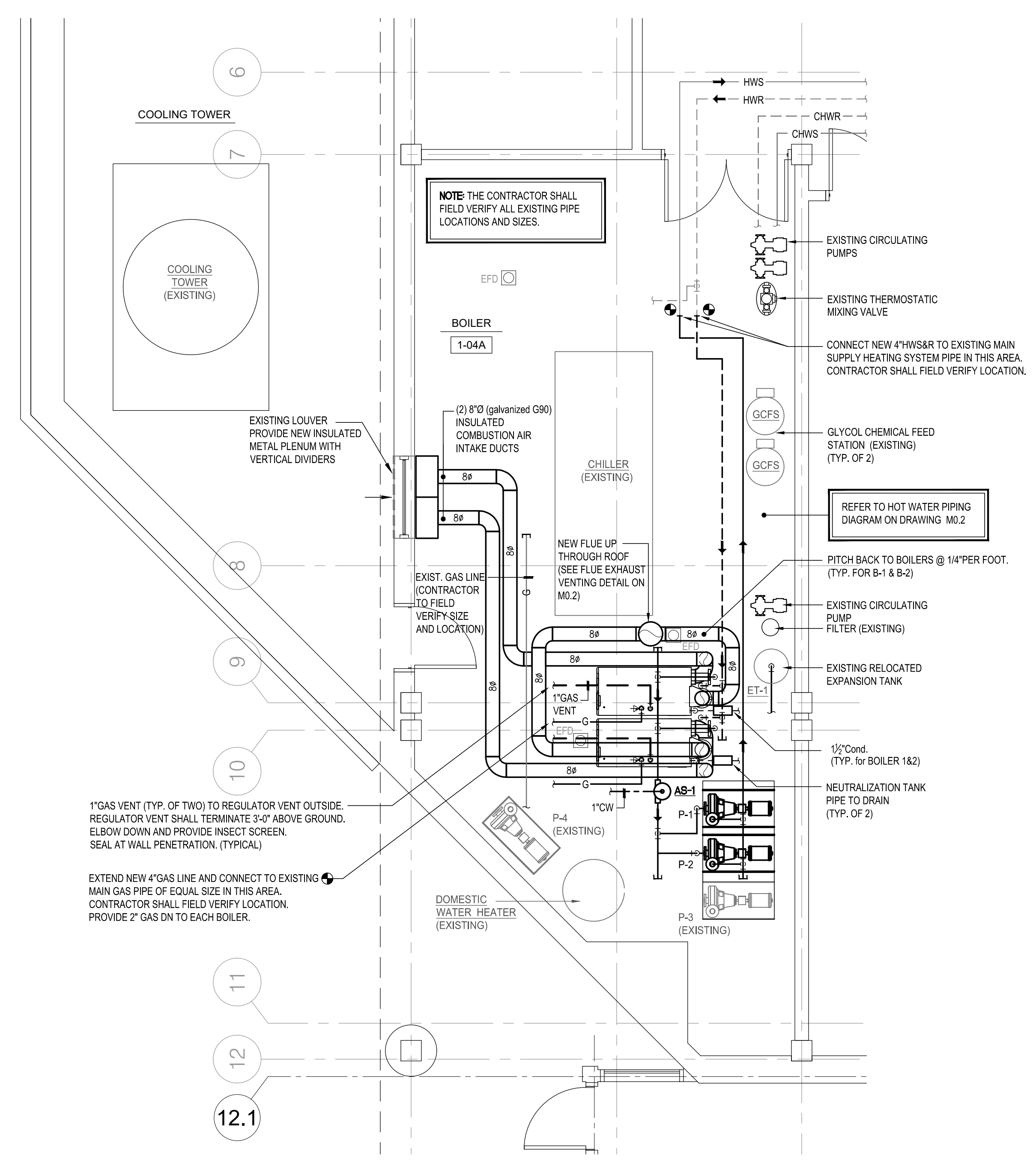

BOILER ROOM PART PLAN - MECHANICAL NEW WORK
SCALE: 1/4"=1'-0"

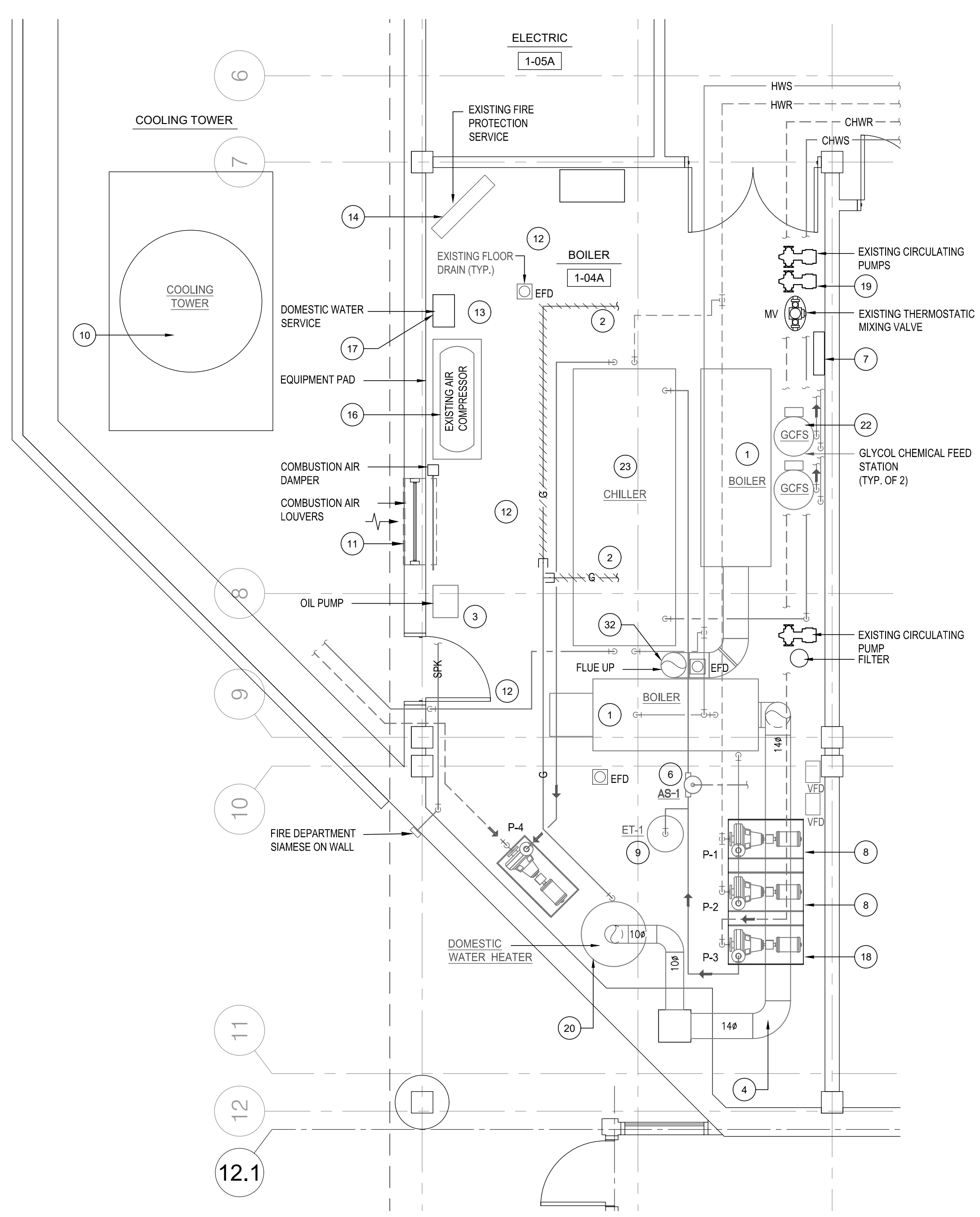

BOILER ROOM PART PLAN - MECHANICAL DEMOLITION
SCALE: 1/4"=1'-0"

- MECHANICAL DEMOLITION WORK SYMBOLS -	
TAG	ACTION
1	EXISTING HEATING BOILER WITH ASSOCIATED PRIMARY PUMP, PIPING, VALVES, ACCESSORIES AND CONCRETE PAD SHALL BE REMOVED. CAP HOT WATER SUPPLY AND RETURN PIPING FOR FUTURE CONNECTION.
2	EXISTING GAS PIPING SHALL BE REMOVED AND CAPPED FOR FUTURE CONNECTION. EXISTING BOILER GAS VENTS SHALL BE REMOVED.
3	EXISTING FUEL OIL PUMP AND CONCRETE PAD SHALL BE REMOVED. PATCH TO MATCH FLOOR. EXISTING FUEL OIL GAUGE SHALL BE REMOVED. EXISTING PIPING SHALL BE REMOVED BACK TO WALL AND CAPPED. OIL IN PIPES SHALL BE DISPOSED OFF SAFELY IN ACCORDANCE WITH LOCAL AND STATE CODE.
4	EXISTING BOILER BREECING SHALL BE REMOVED. PATCH REMAINING CHIMNEY OPENING TO MATCH EXISTING. CONTRACTOR SHALL CLEAN THE INTERIOR OF THE EXISTING CHIMNEY. CONTRACTOR SHALL OPEN THE BOTTOM OF CHIMNEY TO ALLOW FOR INSTALLATION OF NEW FLUE. PROVIDE NEW ACCESS DOOR PATCH TO MATCH.
5	EXISTING UNIT HEATER SHALL REMAIN.
6	EXISTING AIR SEPARATOR AND ASSOCIATED PIPING SHALL BE REMOVED.
7	EXISTING BOILER CONTROL PANEL AND PNEUMATIC CONTROL PANEL SHALL BE REMOVED.
8	EXISTING HOT WATER HEATING PUMPS, ASSOCIATED PIPING, ACCESSORIES AND CONCRETE PAD SHALL BE REMOVED. CAP REMAINING PIPES FOR FUTURE CONNECTION.
9	EXISTING EXPANSION TANK SHALL BE RELOCATED AND SHALL BE USED WITH THE NEW SYSTEM. STORE AT A SAFE LOCATION.
10	EXISTING COOLING TOWER SHALL REMAIN. INTEGRATE UNIT INTO NEW DDC SYSTEM.
11	EXISTING COMBUSTION AIR LOUVER SHALL REMAIN. BLOCK THE BOTTOM OPENING WITH INSULATED PANEL. LEAVE TOP COMBUSTION AIR OPENING AS REQUIRED FOR NEW BOILERS AND NEW DOMESTIC WATER HEATER.
12	EXISTING INSULATION ON ALL PIPING (HEATING AND CHILLED WATER, DOMESTIC WATER AND REFRIGERANT PIPING), SHALL BE REPLACED.
13	EXISTING MAKE-UP WATER WITH BACKFLOW PREVENTER AND PRESSURE REDUCING VALVE SHALL BE REPLACED. PROVIDE NEW REDUCED PRINCIPLE BACK FLOW PREVENTER AND PRESSURE REGULATING VALVE. INSTALL 5/4\"/>

GENERAL DEMOLITION NOTES

- 1- THE CONTRACTOR SHALL BE RESPONSIBLE FOR THE LOCATION AND PROTECTION OF ALL EXISTING UTILITY LINES INCLUDING ELECTRICAL, SEWER, WATER, GAS, TELEPHONE, ETC. THE DRAWINGS SHOW DIAGRAMMATICALLY THE APPROXIMATE LOCATION OF UTILITIES WHERE INFORMATION IS AVAILABLE, BUT THE DRAWINGS ARE NOT EXACT AS TO THE QUANTITY, EXTENT OR LOCATION. THE CONTRACTOR SHALL EXERCISE EXTREME CAUTION DURING ALL PHASES OF THE WORK TO LOCATE, IDENTIFY, AND PROTECT EXISTING UTILITIES. THE CONTRACTOR SHALL RECORD RECORD LOCATION OF AND REPAIR DAMAGE TO EXISTING UTILITIES WHICH ARE ENCOUNTERED AS A RESULT OF WORK UNDER THIS CONTRACT.
- 2- COORDINATE ALL DEMOLITION WORK WITH THE REQUIREMENTS OF THE NEW SCOPE OF WORK.

MECHANICAL DEMOLITION WORK NOTES

- 1- PRIOR TO SUBMITTING BID, VISIT THE SITE AND IDENTIFY EXISTING CONDITIONS AND DIFFICULTIES THAT WILL AFFECT WORK TO BE PERFORMED. NO COMPENSATION WILL BE GRANTED FOR ADDITIONAL WORK CAUSED BY UNFAMILIARITY WITH SITE CONDITIONS THAT ARE VISIBLE OR READILY CONSTRUED BY EXPERIENCED OBSERVERS. INCLUDE IN THE BID ALL DEMOLITION WORK REQUIRED.
- 2- THE DEMOLITION DRAWINGS ARE INTENDED ONLY TO DEFINE THE GENERAL SCOPE OF DEMOLITION WORK AND TO ASSIST THE CONTRACTOR DURING BIDDING. THE DEMOLITION DRAWINGS MAY NOT SHOW EVERY ITEM WHICH MUST BE DISCONNECTED, REMOVED, OR RELOCATED IN ORDER TO FACILITATE NEW WORK. THE CONTRACTOR SHALL BE RESPONSIBLE FOR ALL DEMOLITION WORK REQUIRED WHETHER OR NOT SHOWN ON THE PLANS.
- 3- COORDINATE AND SCHEDULE ALL WORK WITH THE OWNER TO MINIMIZE INCONVENIENCE TO THE BUILDING OCCUPANTS. ALL SERVICES AND SYSTEMS SERVING OCCUPIED AREAS OF THE BUILDING SHALL BE MAINTAINED IN OPERATION DURING WORKING SHIFTS.
- 4- CONTRACTOR IS RESPONSIBLE FOR ANY TEMPORARY WORK REQUIRED TO KEEP THE BUILDING OCCUPIED DURING CONSTRUCTION.
- 5- REMOVE AND/OR RELOCATE ALL EXISTING MECHANICAL WORK AS NECESSARY FOR THE PERFORMANCE OF THE WORK OF THIS CONTRACT.
- 6- REMOVE ALL DEMOLITION MATERIAL FROM THE JOB SITE UNLESS NOTED DIFFERENTLY.
- 7- CONTRACTOR SHALL FIELD VERIFY LOCATION AND SIZE OF EXISTING HOT WATER HEATING SUPPLY AND RETURN PIPING.
- 8- CONTRACTOR SHALL MEASURE AND RECORD EXISTING HEATING SYSTEM PUMP FLOW AND HEAD PRIOR TO ANY DEMOLITION.
- 9- CONTRACTOR SHALL REPLACE INSULATION ON ALL EXISTING PIPING IN THE MECHANICAL ROOM (REFRIGERANT, DOMESTIC HOT AND COLD AND RE-CIRCULATING HOT WATER, CHILLED, HOT WATER AND CONDENSING WATER)
- 10- REPLACE ALL EXISTING THERMOSTATS. CONTRACTOR SHALL FIELD VERIFY LOCATION AND QUANTITY BEFORE SUBMITTING HIS BID. FURNISH AND INSTALL NEW TEMPERATURE SENSORS ABLE TO COMMUNICATE SEAMLESSLY WITH THE NEW BMS.
- 11- TCC SHALL FURNISH NEW CONTROL VALVES TO THE OWNER TO BE INSTALLED BY FACILITY PERSONNEL.

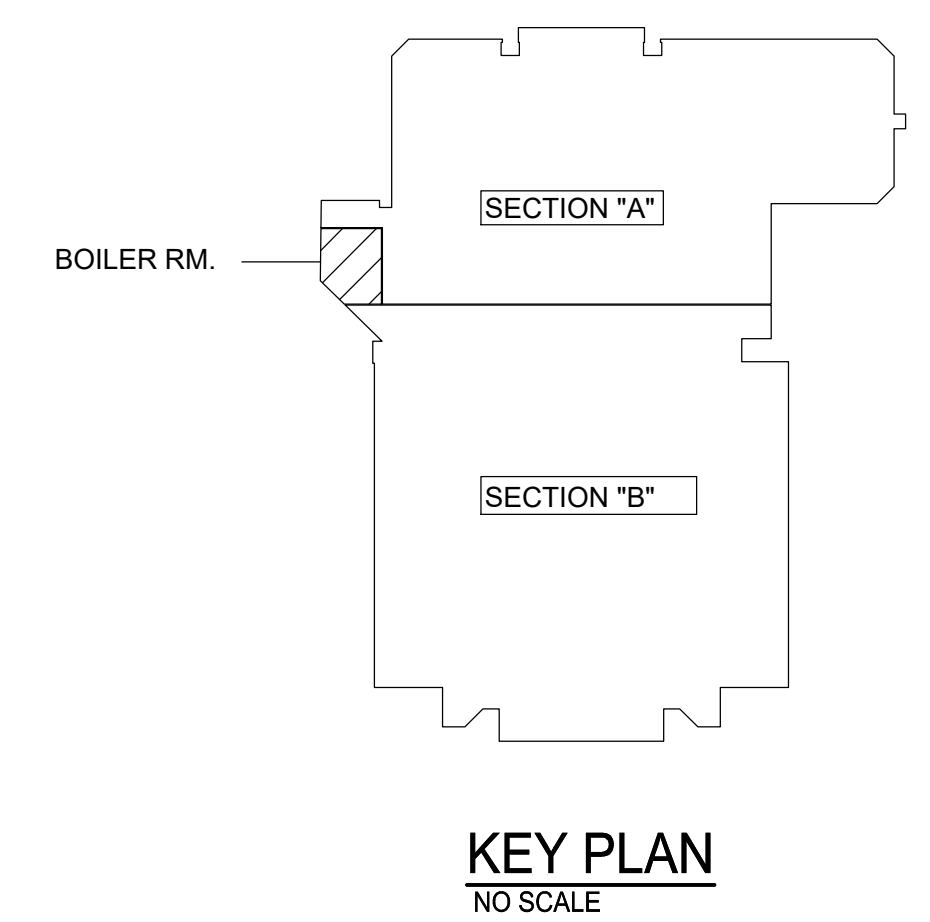

KEY PLAN
NO SCALE

GAS FIRED, HOT WATER BOILER SCHEDULE (4"WC NATURAL GAS)																
TAG	LOCATION	MANUF.	MODEL	WATER FLOW (MIN/MAX) (GPM)	WATER VOLUME (GAL)	FUEL	GAS			ELECTRICAL			VENT DIA (inch)		REMARKS	
							INPUT (MBH)	OUTPUT (MBH)	PRESSURE (MIN/MAX)	THERMAL EFFICIENCY	VOLTAGE	PHASE	FLA	(INTAKE)		(OUT)
B-1	MECHANICAL RM	AERCO	BENCHMARK 3000	25-350	55	GAS	3000	2790	4"WC MIN	94.6%	460	3	15	8	8	1,2,3,4,5,6
B-2	MECHANICAL RM	AERCO	BENCHMARK 3000	25-350	55	GAS	3000	2790	4"WC MAX	94.6%	460	3	15	8	8	1,2,3,4,5,6

REMARKS:
 1. REFER TO SPECIFICATIONS FOR ADDITIONAL INFORMATION.
 2. POWER WIRING AND RACEWAY BY DIVISION 26.
 3. DISCONNECT MOTOR STARTERS AND CONTROLS BY DIVISION 23.
 4. PROVIDE WATER LEVEL CONTROLS.
 5. UNIT MANUFACTURER SHALL PROVIDE LOCK-UP STYLE REGULATOR. REGULATOR SHALL BE INDEPENDENTLY VENTED TO OUTSIDE.
 6. UNIT MANUFACTURER SHALL PROVIDE CONDENSATE NEUTRALIZATION TUBE, JM-30.

VFD SCHEDULE						
UNIT SERVED	MANUF.	MODEL	HP	VOLTS	PH.	REMARKS
P-1	ABB	ACH 550	7.5	460	3	
P-2	ABB	ACH 550	7.5	460	3	

PUMP SCHEDULE																			
PUMP No.	LOCATION	AREA SERVED	TYPE	MANUFACTURER	SERIES	MODEL	GPM	HEAD (FT)	RPM	HP	VOLTS	PH	Duty point Pump EFFICIENCY	SUCTION DIFFUSER			TRIPLE DUTY VALVE	REMARKS	
														MODEL	SYS. SIDE	SUCT. SIDE			
P-1	MECHANICAL RM	HEATING SYSTEM	BASE MTD.	BELL & GOSSETT	e-1510	3BD	280	55	16.5	1800	7.5	460	3	75.1%	EE-3X	4	4	30S-4S	1,2,3,5,6
P-2	MECHANICAL RM	HEATING SYSTEM (STAND-BY)	BASE MTD.	BELL & GOSSETT	e-1510	3BD	280	55	16.5	1800	7.5	460	3	75.1%	EE-3X	4	4	30S-4S	1,2,4,5,6

REMARKS:
 1. UNIT SHALL BE SEISMICALLY SUPPORTED.
 2. INSTALL ACCORDING TO MANUFACTURER'S RECOMMENDATIONS.
 3. OPERATING.
 4. STANDBY.
 5. PROVIDE WITH PREMIUM EFFICIENCY MOTOR.
 6. PROVIDE VARIABLE FREQUENCY DRIVE.

ENGINEERING SPECIFICATION FOR BELL & GOSSETT ROLAIR/ROL AIR SEPARATOR (HOT WATER SIDE)

Furnish and install as shown on plans, a centrifugal type air separator. The unit shall have 4" Flanged or Grooved inlet and outlet connections tangential to the vessel shell. Vessel shell diameter to be three times the nominal inlet/outlet pipe diameter.

The unit shall have an internal stainless steel air collector tube with 5/32" diameter perforations and 63% open area designed to direct accumulated air to the compression tank via an NPT connection at top of unit.

The unit shall have a removable galvanized steel system strainer with 3/16" diameter perforations and a free area of not less than five times the cross-sectional area of the connecting pipe. A blow-down connection shall be provided to facilitate routine cleaning of the strainer.

Manufacturer to furnish data sheet specifying air collection efficiency and pressure drop at rated flow.

The air separator(s) must be designed, constructed, and stamped for 125 psig @ 350°F in accordance with Section VIII, Division 1 of the ASME Boiler and Pressure Vessel Code, and registered with the National Board of Boiler and Pressure Vessel Inspectors. The air separator(s) shall be painted with one shop coat of light gray air dry enamel.

A Manufacturer's Data Report for Pressure Vessels, Form U-1 as required by the provisions of the ASME Boiler and Pressure Vessel Code shall be furnished for each air separator upon request.

The manufacturer shall be ITT Bell & Gossett, Model R-4F

The unit shall be: 20.5" long, 31.44" high, 12.75" wide.
 Shipping Weight 170.0 pounds, Flooded Weight 278.0 pounds

GENERAL MECHANICAL NOTES:

- DRAWINGS ARE DIAGRAMMATIC AND SHOW GENERAL INTENT OF WORK. ALL CONTRACTORS MUST COORDINATE WITH OTHER TRADES OTHER TRADES BEFORE PROCEEDING WITH ANY WORK.
- THE CONTRACTOR SHALL COORDINATE THE ROUTING AND INSTALLATION OF ALL SYSTEMS TO AVOID CONFLICTS.
- THE CONTRACTOR SHALL VISIT THE SITE AND FAMILIARIZE HIMSELF WITH THE EXISTING CONDITIONS PRIOR TO SUBMITTING HIS BID.
- THE CONTRACTOR SHALL FIELD VERIFY ALL EXISTING PIPE LOCATIONS AND SIZES.
- INSTALL PIPES TO ALLOW EASY ACCESS TO VALVES.
- INSULATE ALL HOT WATER HEATING SUPPLY AND RETURN PIPING AND DOMESTIC WATER PIPING.
- INSULATE ALL EXISTING CHILLED WATER SUPPLY AND RETURN PIPING.
- BRANCH TAKE-OFFS FOR FLUE AND COMBUSTION AIR SHALL BE AT 45° ANGLES.
- THE CONTRACTOR SHALL BE RESPONSIBLE FOR ANY TEMPORARY WORK REQUIRED TO KEEP THE BUILDING OCCUPIED DURING THE CONSTRUCTION.
- CLEAN AND DISINFECT EXISTING DUCTWORK.
- EXISTING FIN TUBE RADIATION SHALL REMAIN, CLEAN AND DISINFECT FINS. (TYPICAL)
- EXISTING CABINET UNIT HEATER SHALL REMAIN, CLEAN AND DISINFECT FINS. (TYPICAL)
- EXISTING UNIT HEATER SHALL REMAIN, CLEAN AND DISINFECT FINS. (TYPICAL)
- CLEAN AND DISINFECT EXISTING AIR HANDLING UNIT COILS, REPLACE FILTERS. (TYPICAL)

MECHANICAL SYMBOL LIST

SYMBOL	ABBREV.	DESCRIPTION
---	HWS	HOT WATER HEATING SUPPLY
----	HWR	HOT WATER HEATING RETURN
---	CW	COLD WATER
---	HW	HOT WATER SUPPLY
----	HWR	HOT WATER RECIRCULATING
---	D	DRAIN
---	G	NATURAL GAS
---	EG	EXISTING NATURAL GAS
---	CND	CONDENSATE DRAIN
---	SV	SHUTOFF VALVE
---	GSV	GAS SHUTOFF VALVE
---	RD	RISER DOWN
---	RU	RISER UP
---	RO	RISE OR DROP
---	FD	BRANCH-TOP CONNECTION
---	POC	EXISTING FLOOR DRAIN
---	AHU	AIR HANDLING UNIT
---	CH	AIR COOLED CHILLER
---	CUH	CABINET UNIT HEATER
---	CONV	CONVECTOR
---	CHP	CHILLED WATER PUMP
---	FT	FIN TUBE RADIATION
---	MAU	MAKE UP AIR UNIT
---	UH	UNIT HEATER
---	2C	2 WAY CONTROL VALVE
---	T	THERMOSTAT
---	CEF	CEILING MOUNTED EXHAUST FAN
---	REF	ROOF MOUNTED EXHAUST FAN
---	EF	EXHAUST FAN

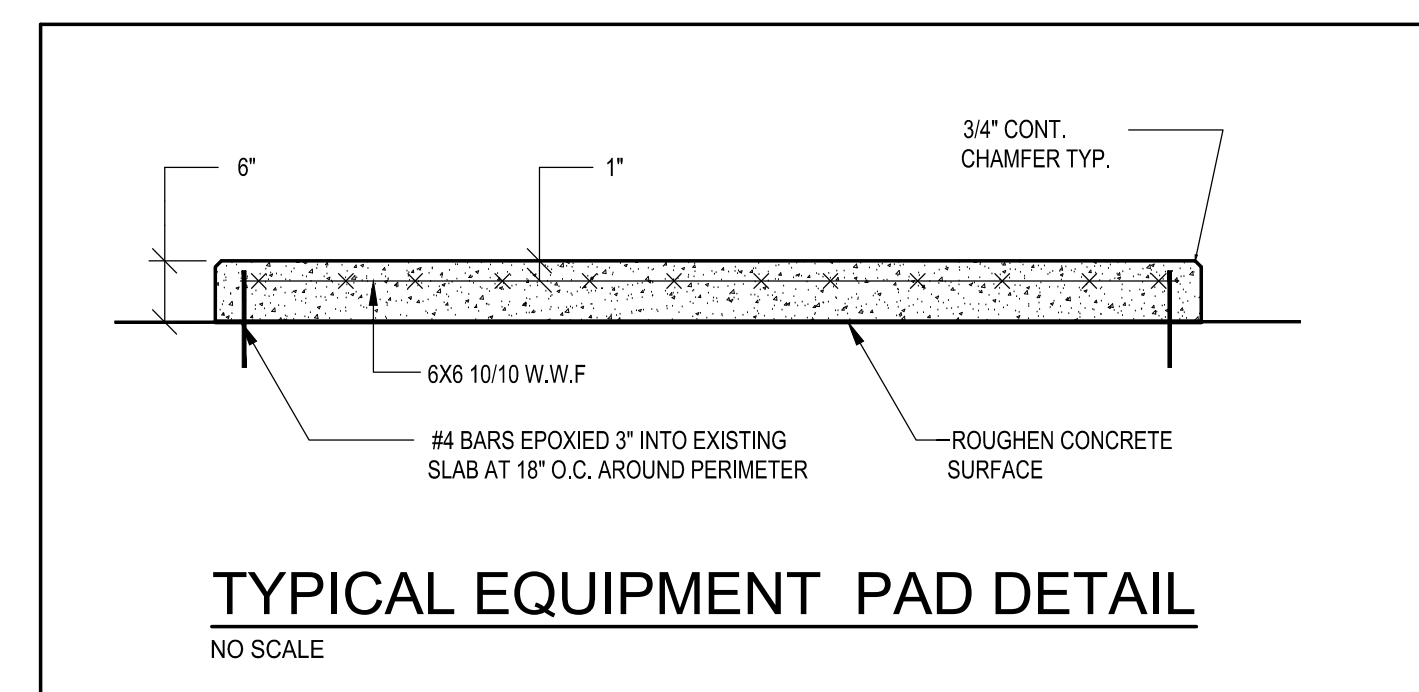
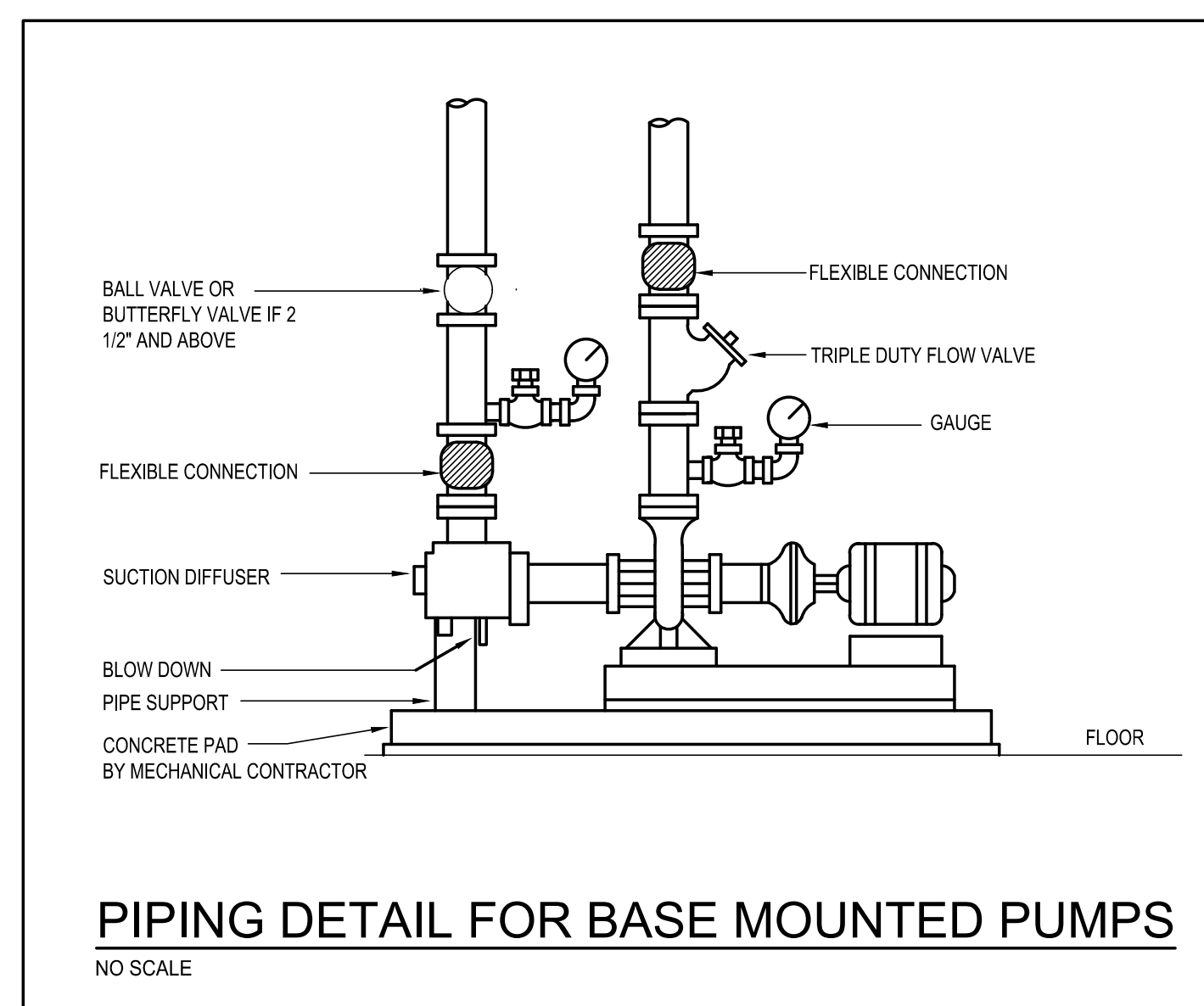
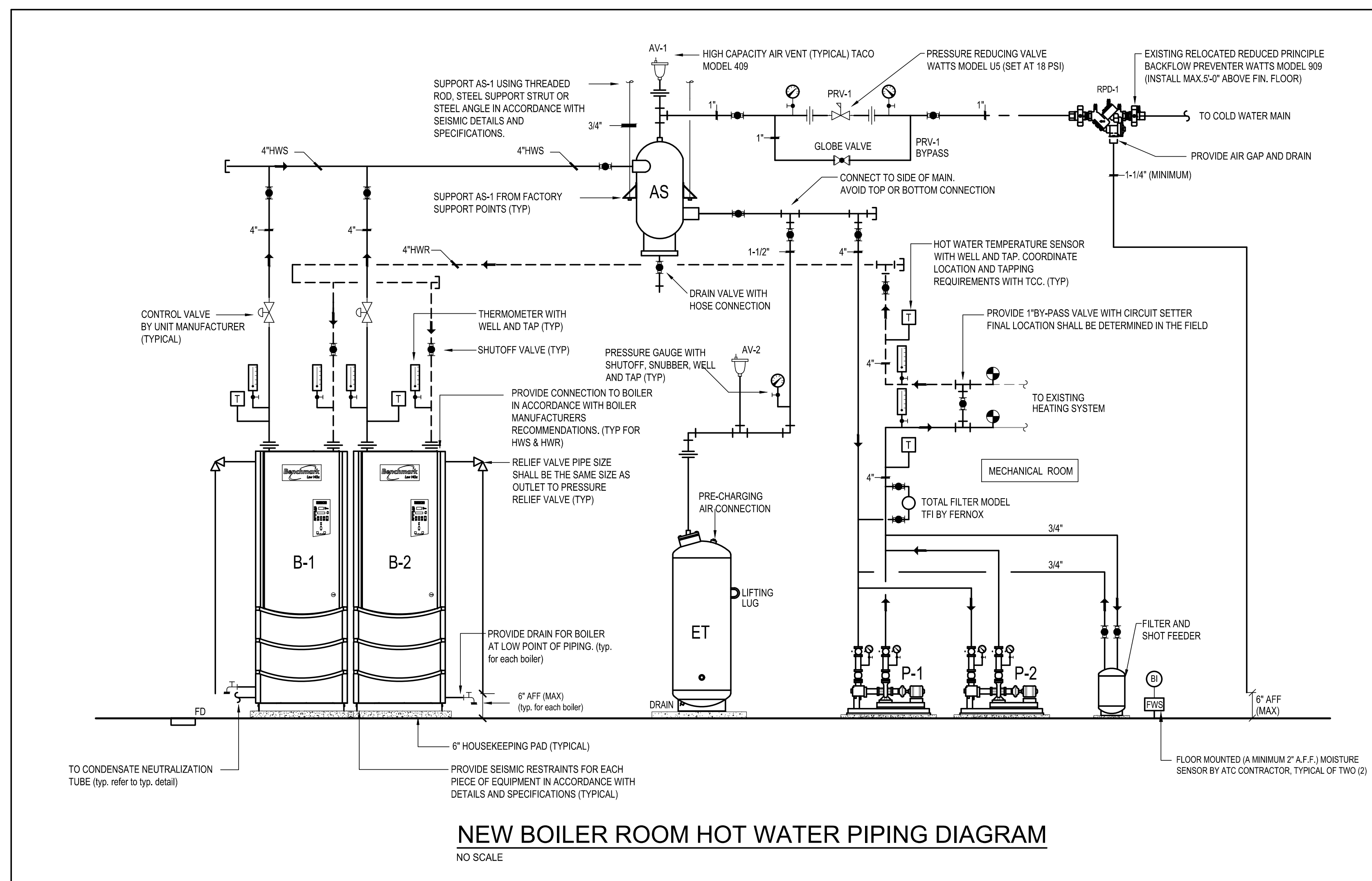
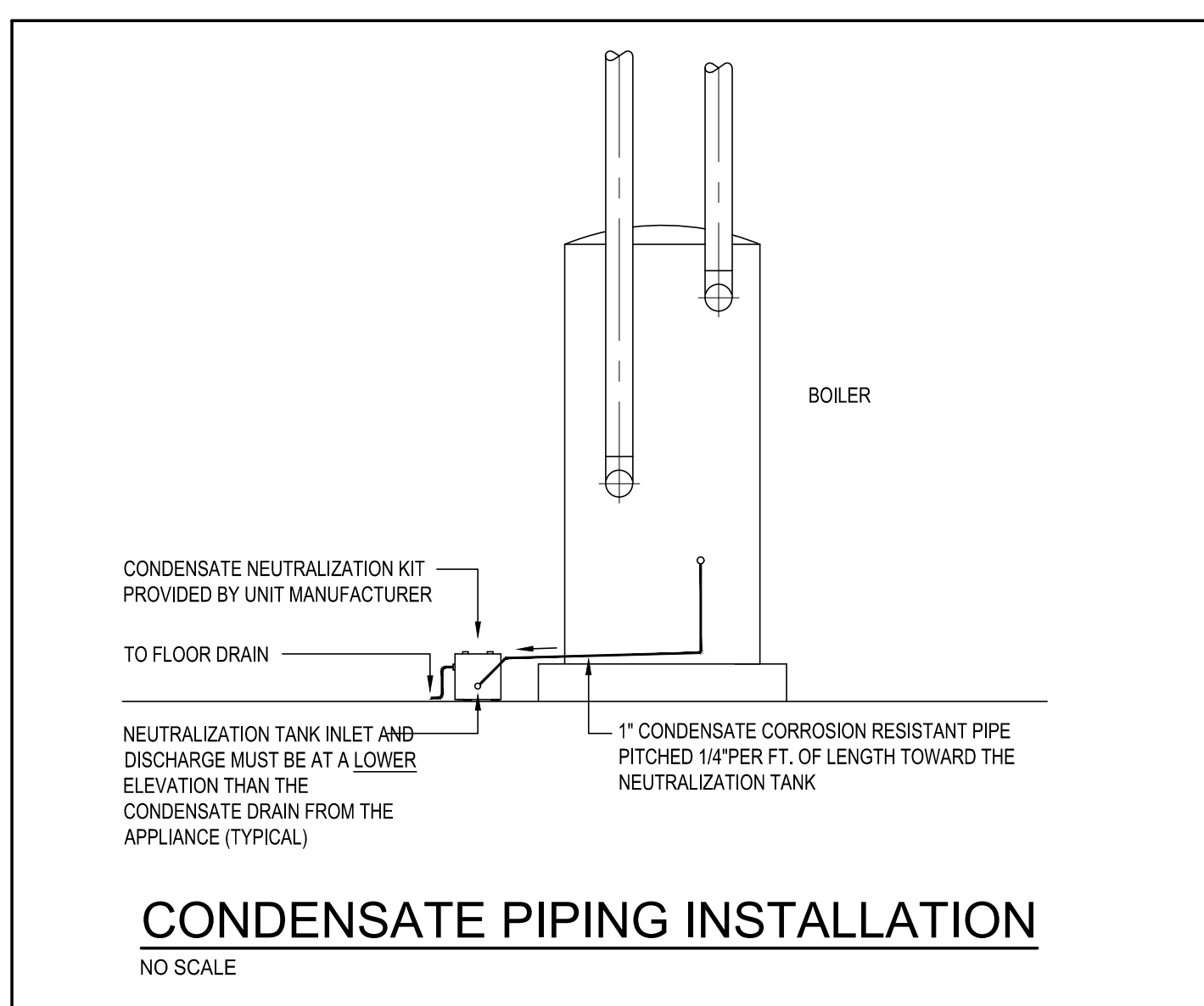
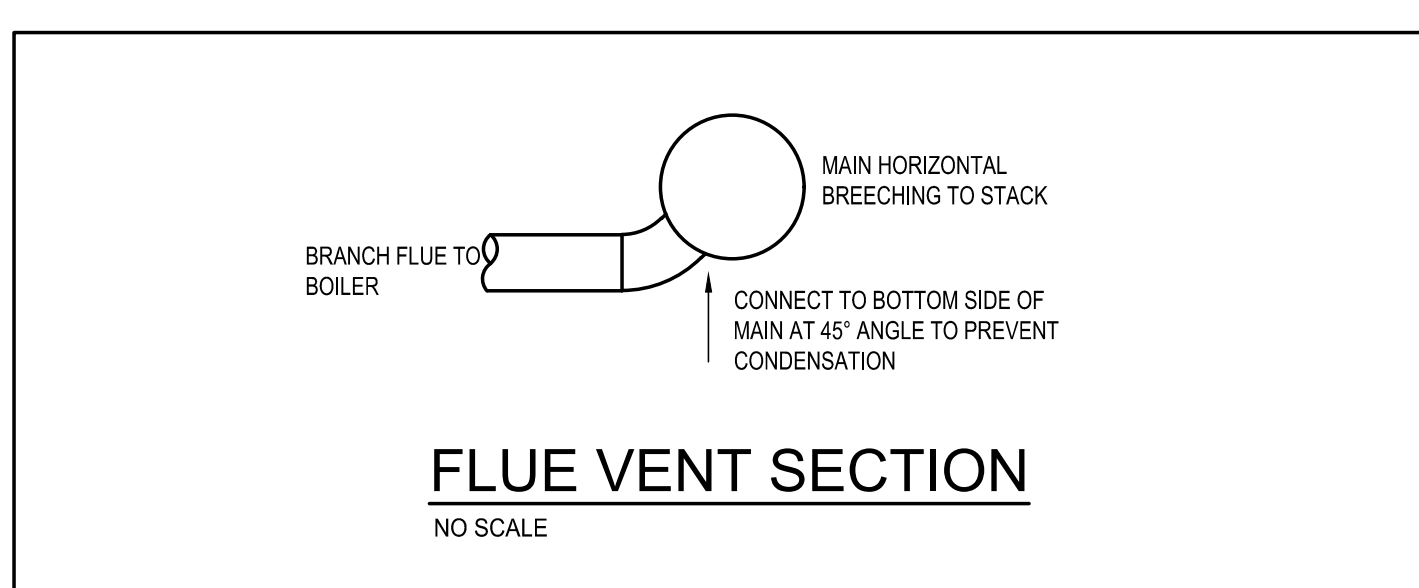
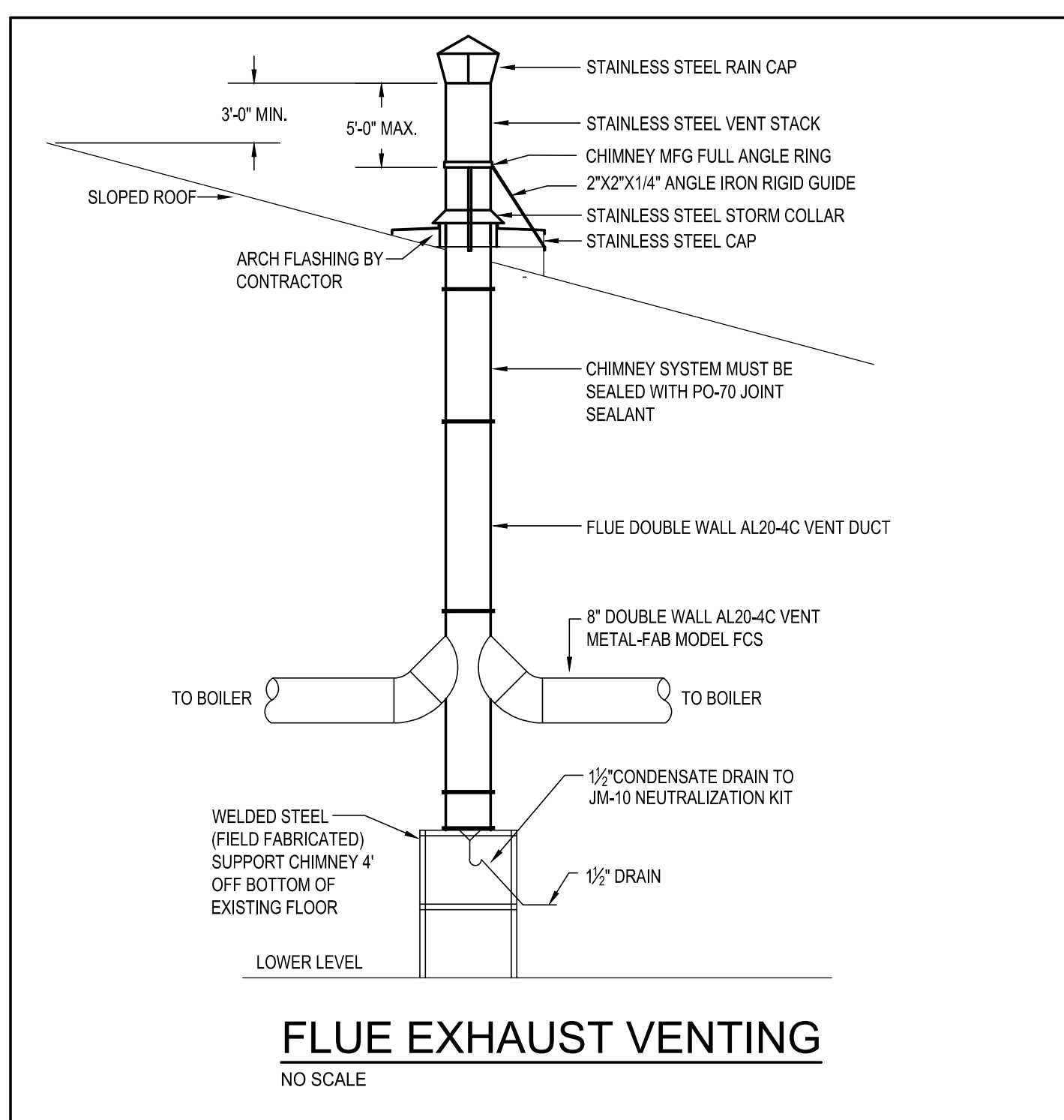

WASHINGTON MIDDLE SCHOOL
BOILER REPLACEMENT
 MERIDEN, CONNECTICUT

BEMS ASSOCIATES, L.L.C.
 Consulting Engineers
 185 Main Street
 Farmington, CT 06032
 Tel: (860) 321-7070
 Fax: (860) 321-7070
 www.bemsassociates.com

TITLE:
 MECHANICAL SCHEMATIC PIPING DIAGRAM, DETAILS AND SCHEDULES

DATE: 03/14/2024

DWG. NO. **M0.2**

COPYRIGHT
 This drawing is the property of BEMIS ASSOCIATES, L.L.C. and shall remain the property of BEMIS ASSOCIATES, L.L.C. No part of this drawing may be reproduced, stored in a retrieval system, or transmitted in any form or by any means, electronic, mechanical, photocopying, recording, or by any information storage and retrieval system, without the prior written permission of BEMIS ASSOCIATES, L.L.C.
 Minimum reproduction of this drawing to meet the needs of other projects or drawings shall be limited to the minimum reproduction of this drawing. Any reproduction of this drawing shall be made at the discretion of BEMIS ASSOCIATES, L.L.C. and shall be subject to the same terms and conditions as the original drawing. Any adjustment or variation of this drawing shall be the responsibility of the user and shall be made at the user's discretion and shall be made to the benefit of the user.

**WASHINGTON MIDDLE SCHOOL
 BOILER REPLACEMENT
 MERIDEN, CONNECTICUT**

BEMIS ASSOCIATES, L.L.C.
 Consulting Engineers
 185 Main Street
 Farmington, CT 06032
 Tel: (860) 321-7070
 Fax: (860) 321-7070
 www.bemisassociates.com

TITLE
MECHANICAL DETAILS

DATE **03/14/2024**

DWG. NO.
M0.3

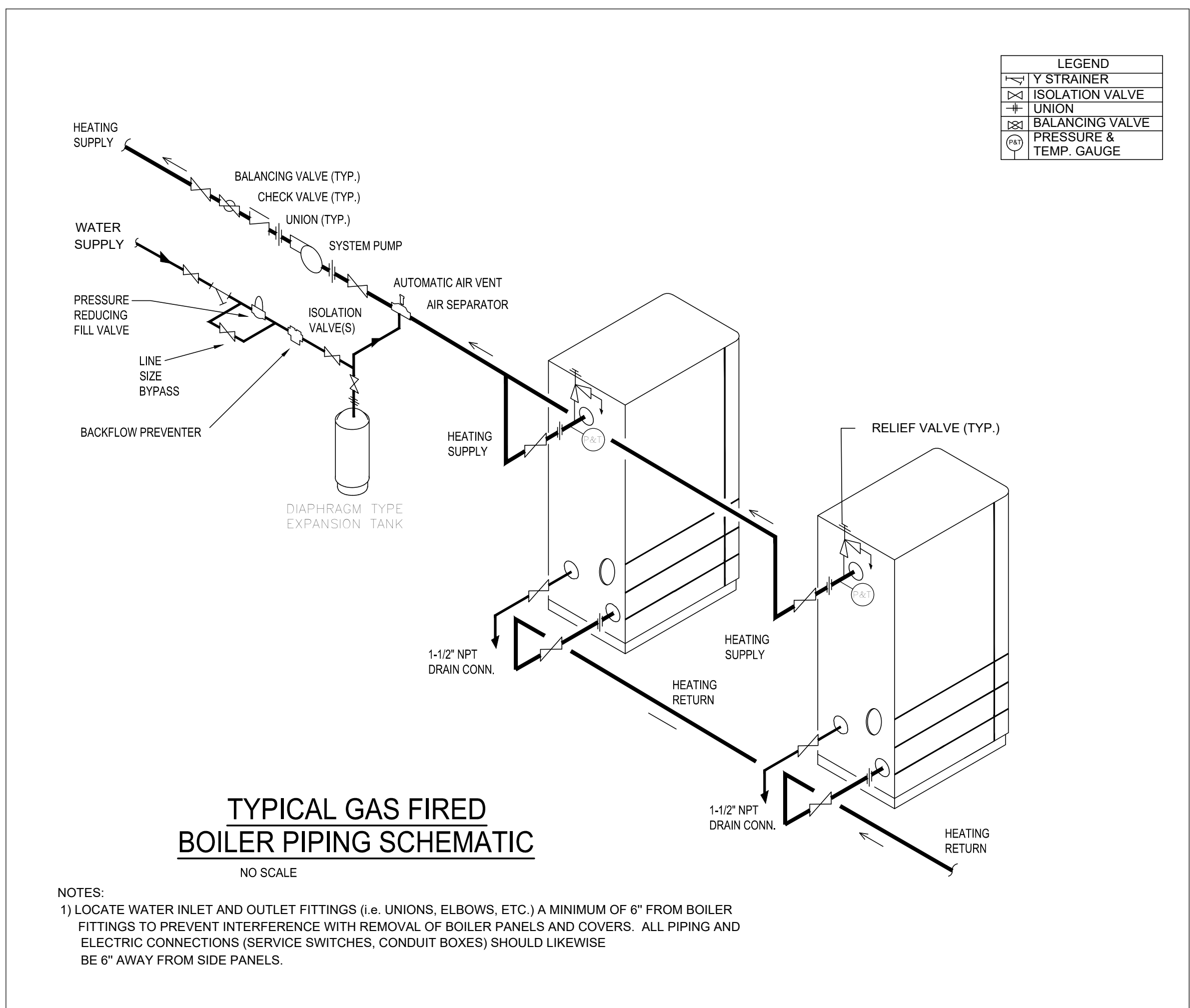
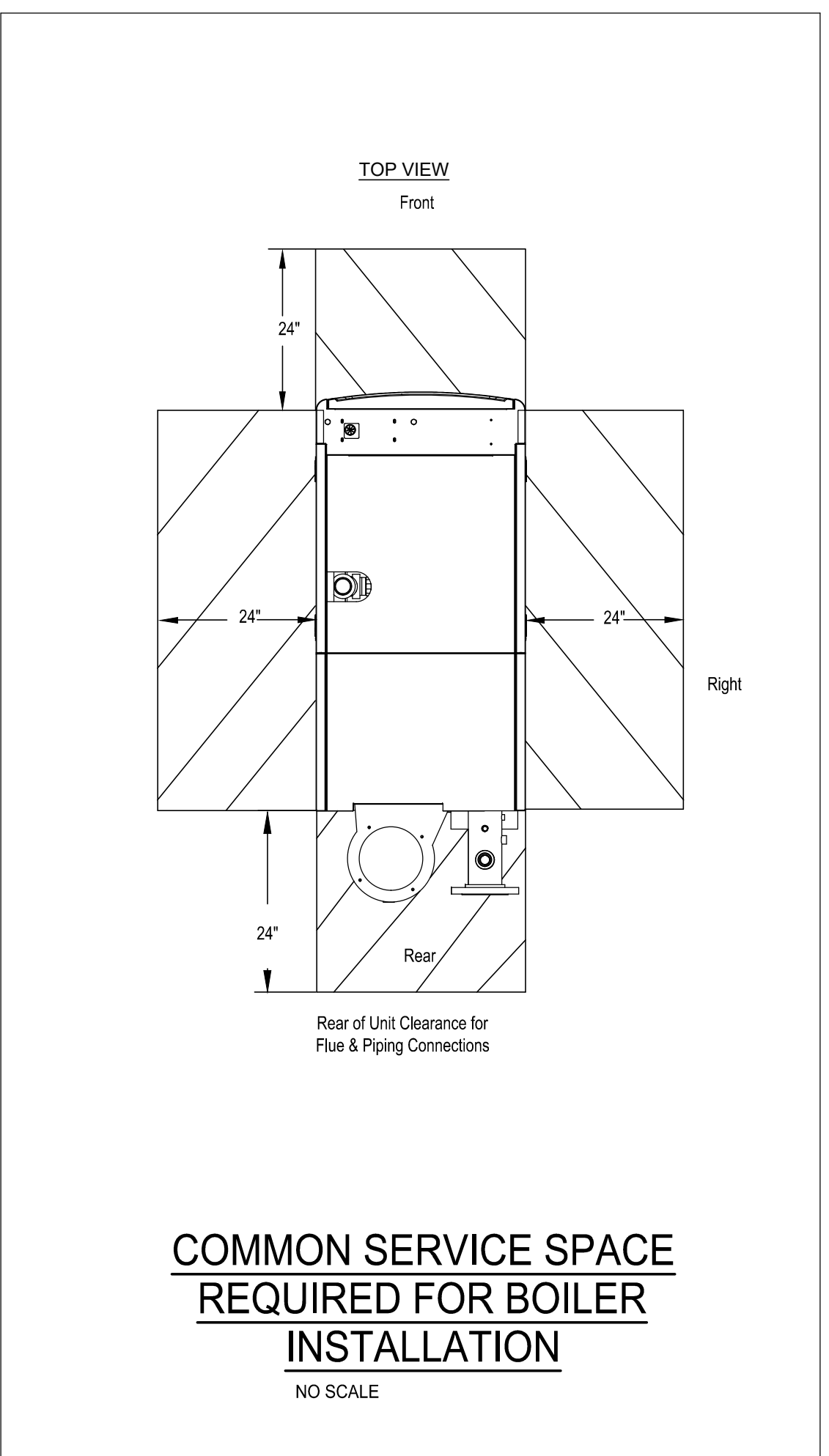
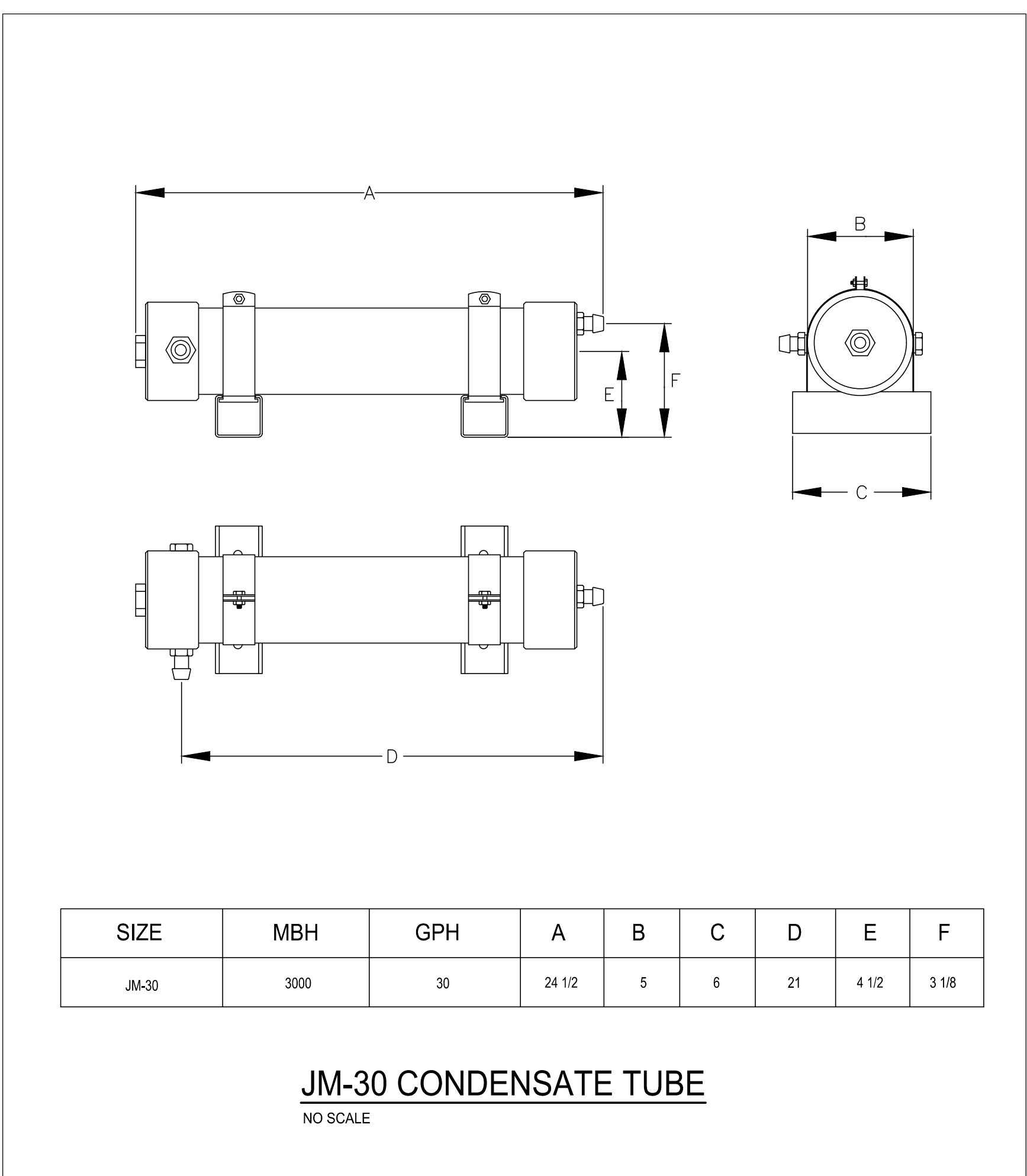
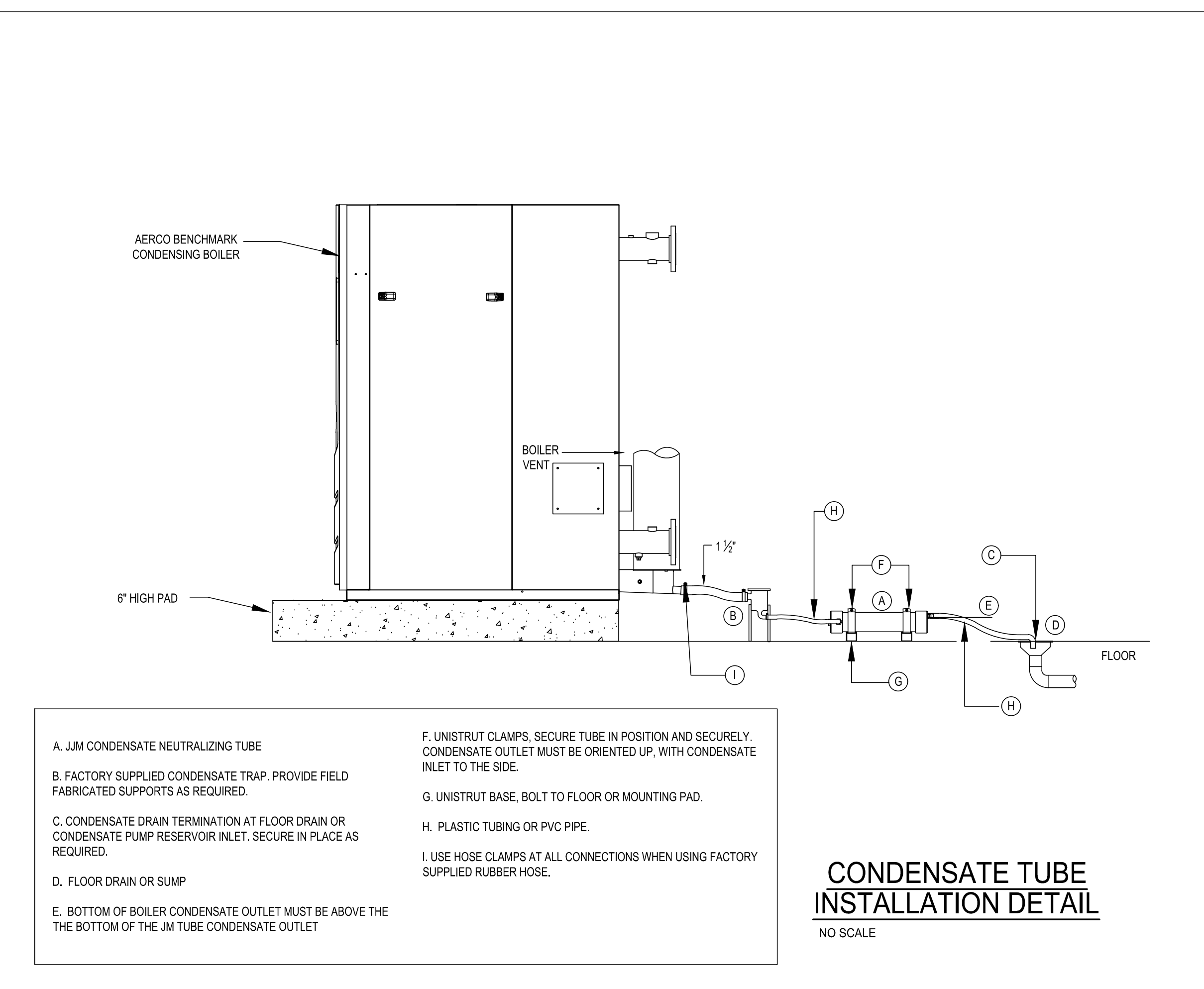
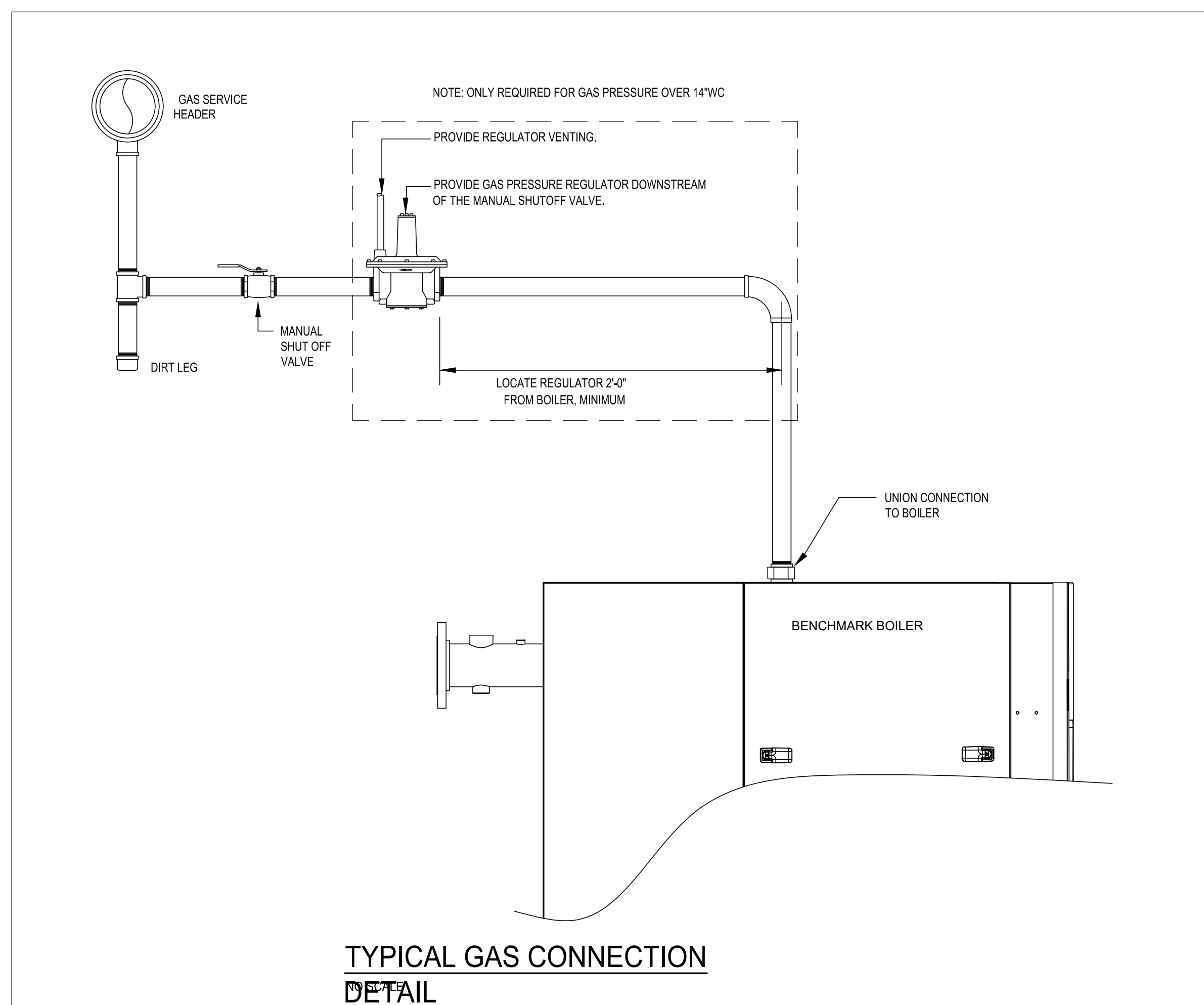

© COPYRIGHT
This drawing is an instrument of service and shall remain the property of BEMIS ASSOCIATES, L.L.C. No part of this drawing may be reproduced, stored in a retrieval system, or transmitted in any form or by any means, electronic, mechanical, photocopying, recording, or by any information storage and retrieval system, without the prior written permission of BEMIS ASSOCIATES, L.L.C.
Minimum or maximum dimensions shown on this drawing are for informational purposes only and shall not be used as a basis for construction. All dimensions shall be in accordance with the project specifications and shall be subject to change without notice.
Any dimensions or conditions of this drawing that conflict with the project specifications shall be governed by the project specifications.
All dimensions are in feet and inches unless otherwise noted.

WASHINGTON MIDDLE SCHOOL BOILER REPLACEMENT

MERIDEN, CONNECTICUT

BEMIS ASSOCIATES, L.L.C.
Consulting Engineers
185 Main Street
Farmington, CT 06032
Tel: (860) 321-7070
www.bemisassociates.com

TITLE:
1st FLOOR SECTION "A" MECHANICAL
DEMOLITION and
NEW WORK

DATE: 03/14/2024

DWG. NO.
M1.1

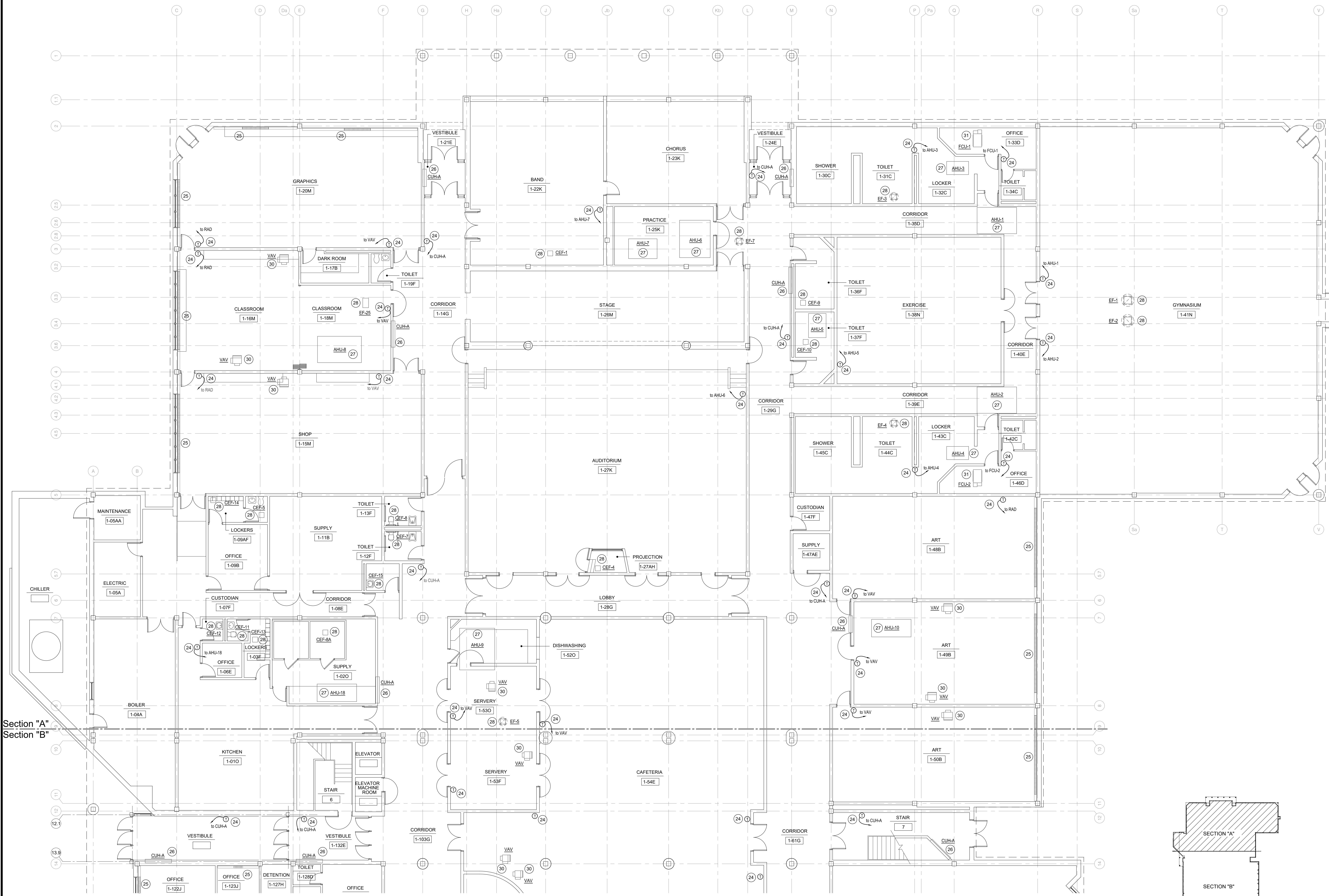

Section "A"
Section "B"

1st FLOOR PLAN SECTION "A" - MECHANICAL
SCALE: 1/8"=1'-0"

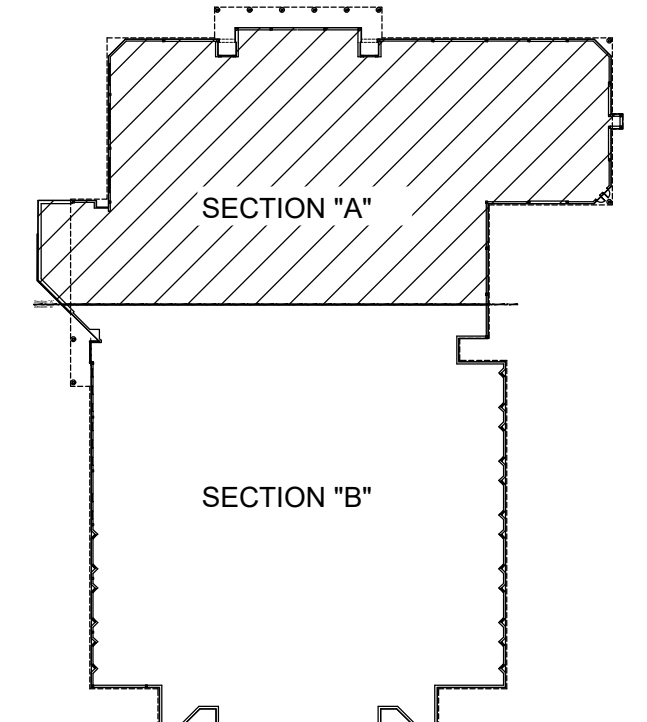

KEY PLAN
NO SCALE

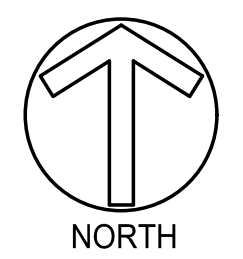

COPYRIGHT
This drawing is the property of BEMIS ASSOCIATES, L.L.C. and shall remain the property of BEMIS ASSOCIATES, L.L.C. No part of this drawing may be reproduced, stored in a retrieval system, or transmitted in any form or by any means, electronic, mechanical, photocopying, recording, or by any information storage and retrieval system, without the prior written permission of BEMIS ASSOCIATES, L.L.C.
Minimum of 10 copies of this drawing to be provided to the owner and the architect.
This drawing is the property of BEMIS ASSOCIATES, L.L.C. and shall remain the property of BEMIS ASSOCIATES, L.L.C. No part of this drawing may be reproduced, stored in a retrieval system, or transmitted in any form or by any means, electronic, mechanical, photocopying, recording, or by any information storage and retrieval system, without the prior written permission of BEMIS ASSOCIATES, L.L.C.

WASHINGTON MIDDLE SCHOOL BOILER REPLACEMENT MERIDEN, CONNECTICUT

BEMIS ASSOCIATES, L.L.C.
Consulting Engineers
185 Main Street
Farmington, CT 06032
Tel: (860) 321-7070
Fax: (860) 321-7070
www.bemisassociates.com

TITLE
2nd FLOOR SECTION "B"
MECHANICAL
DEMOLITION and
NEW WORK

DATE 03/14/2024

DWG. NO.
M2.1

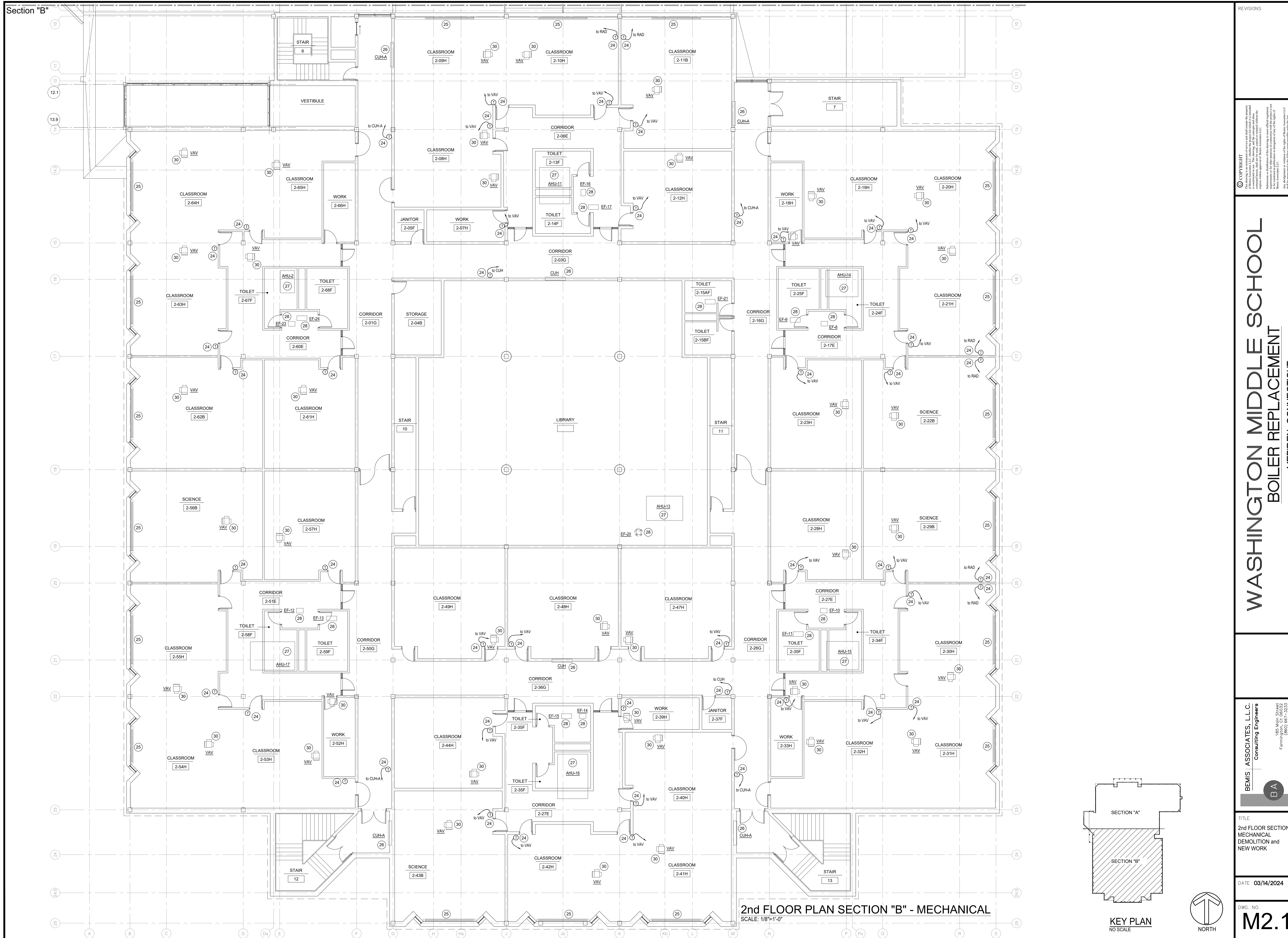

2nd FLOOR PLAN SECTION "B" - MECHANICAL
SCALE: 1/8"=1'-0"

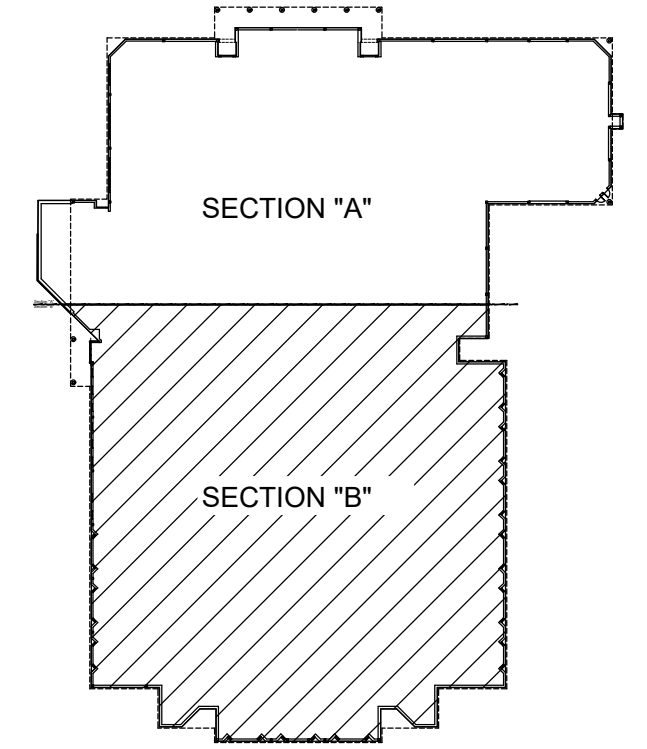

KEY PLAN
NO SCALE

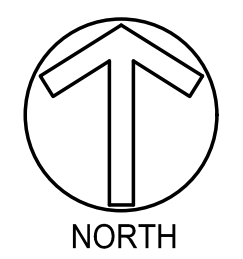

Copyright © 2024 by BEMIS ASSOCIATES, L.L.C. All rights reserved. This drawing is the property of BEMIS ASSOCIATES, L.L.C. and is intended for use only in the project and for the specific use stated herein. No part of this drawing may be reproduced or transmitted in any form or by any means, electronic or mechanical, including photocopying, recording, or by any information storage and retrieval system, without the prior written permission of BEMIS ASSOCIATES, L.L.C. Any duplication or violation of the rights of BEMIS ASSOCIATES, L.L.C. shall be prosecuted to the fullest extent of the law.

WASHINGTON MIDDLE SCHOOL BOILER REPLACEMENT MERIDEN, CONNECTICUT

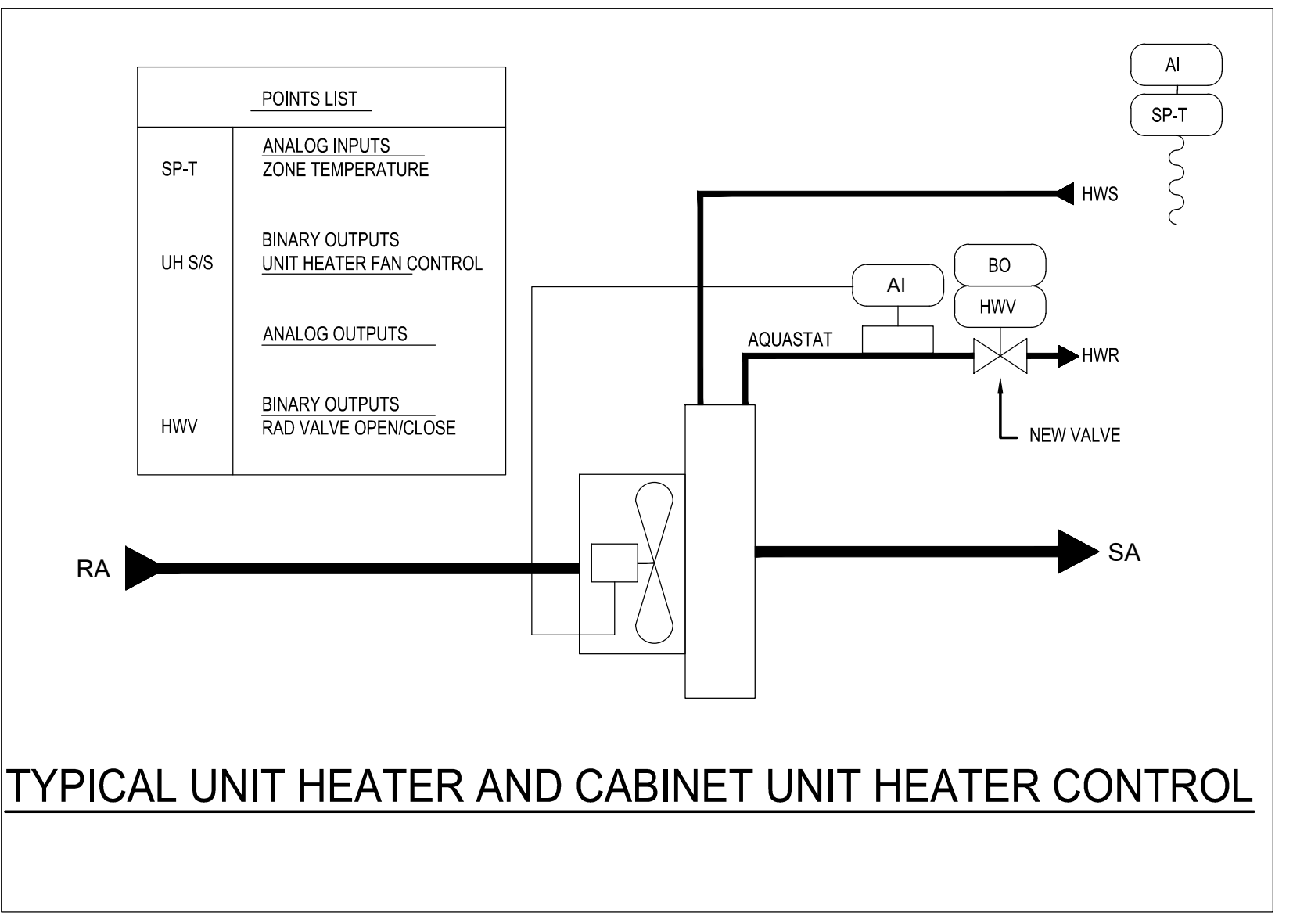
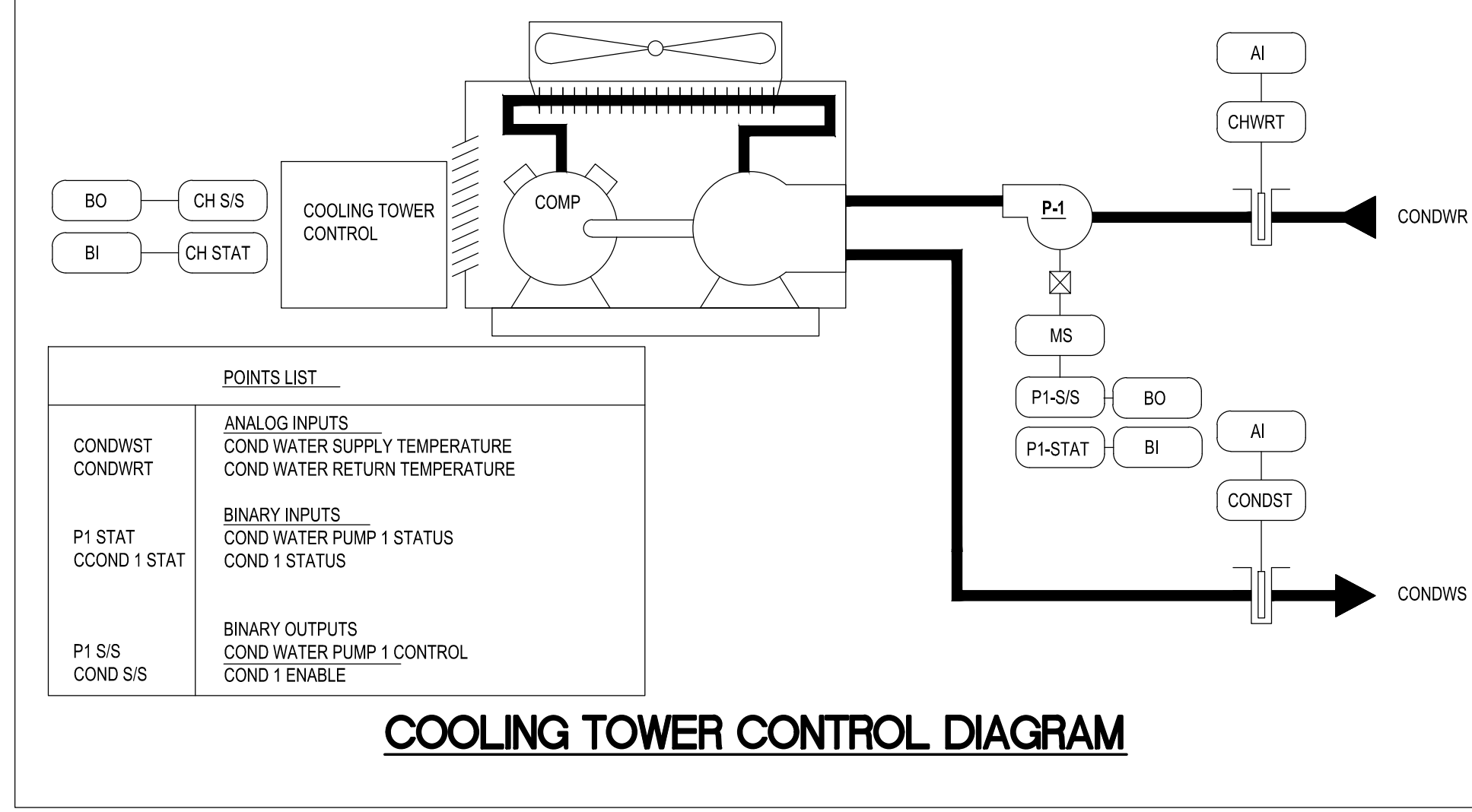
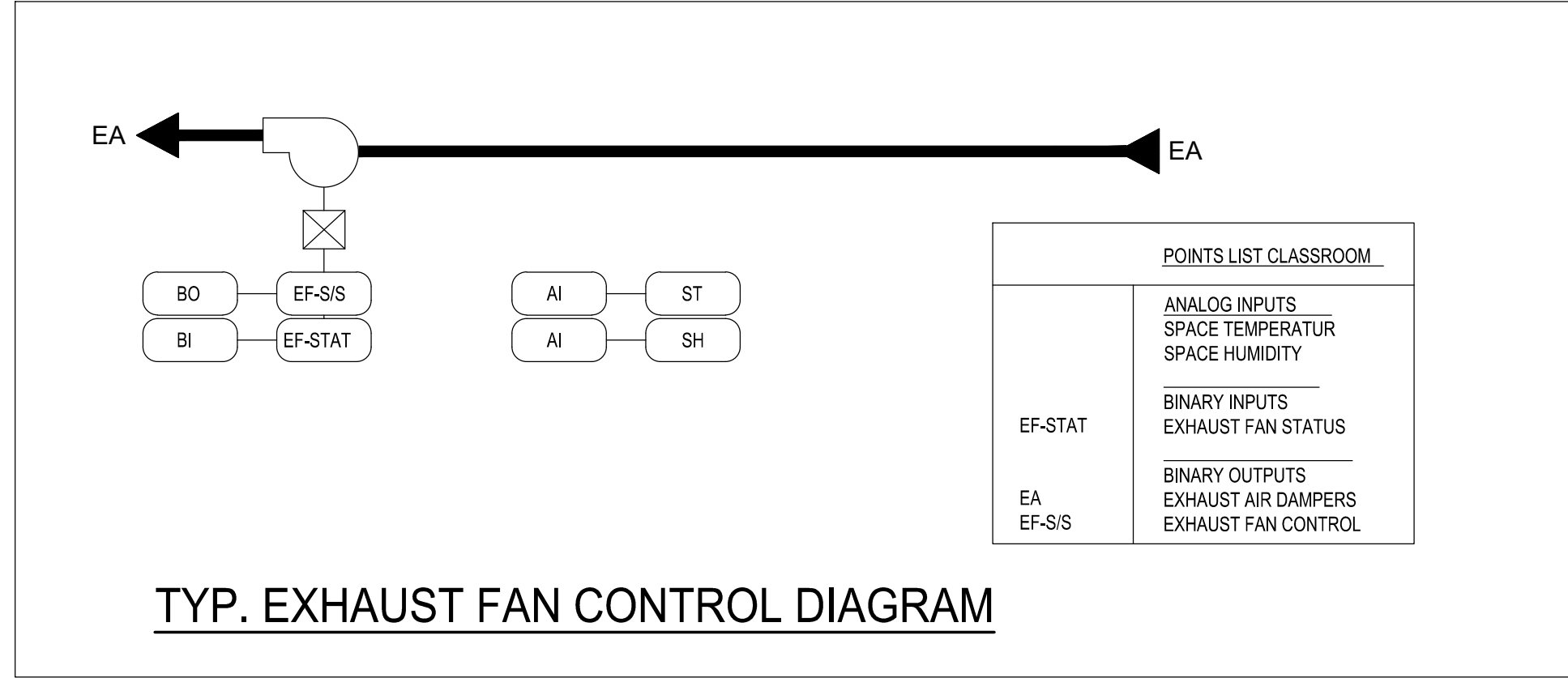
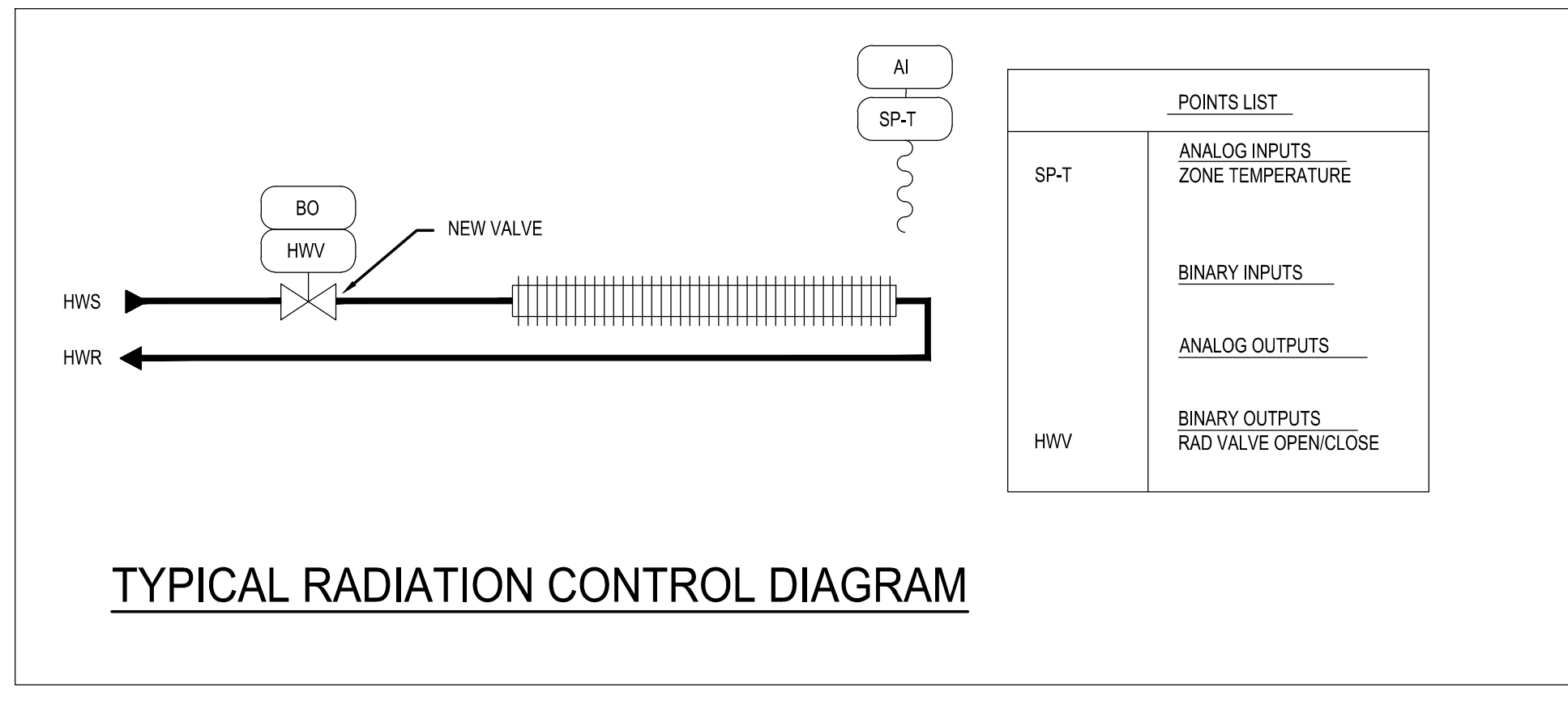
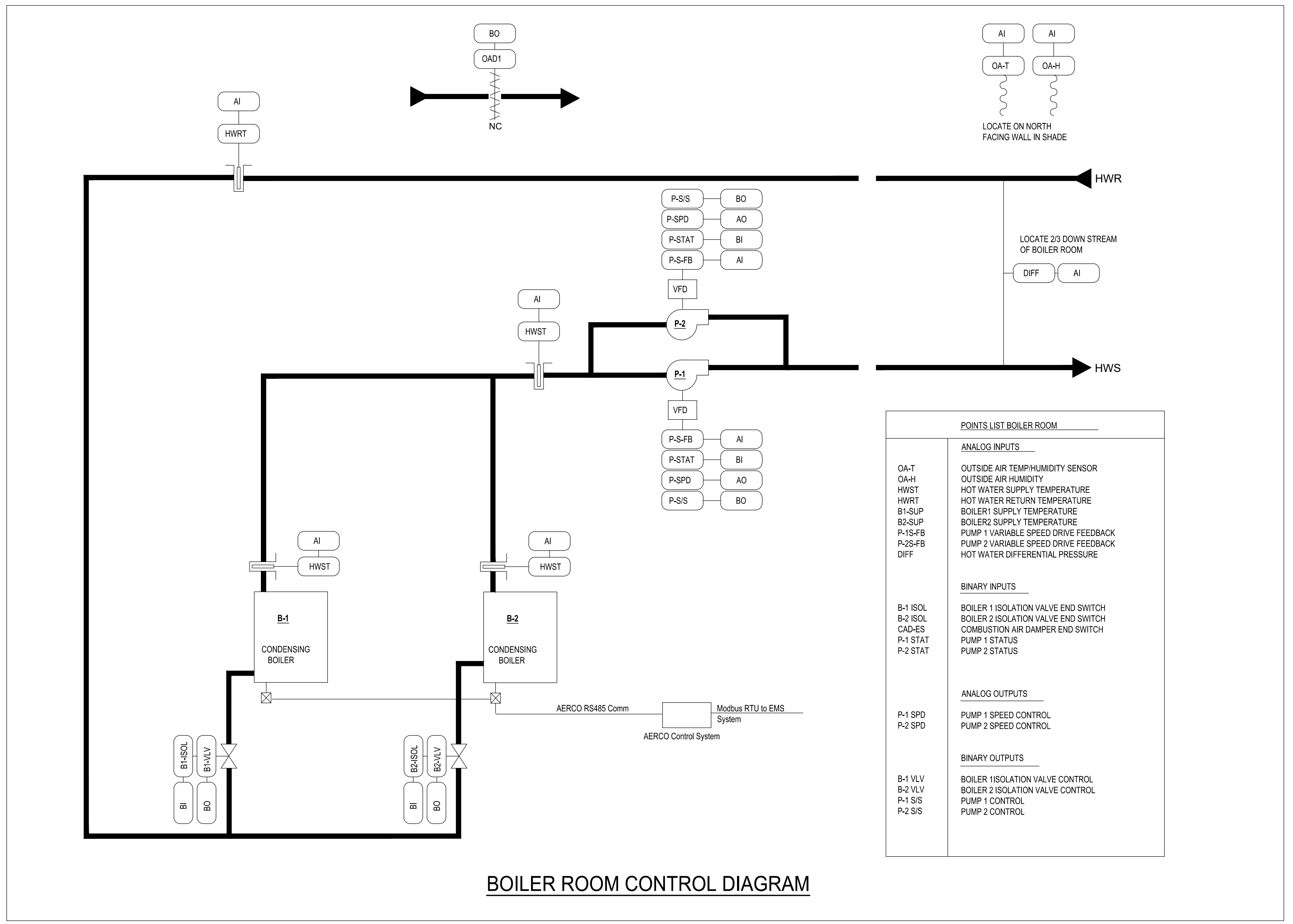
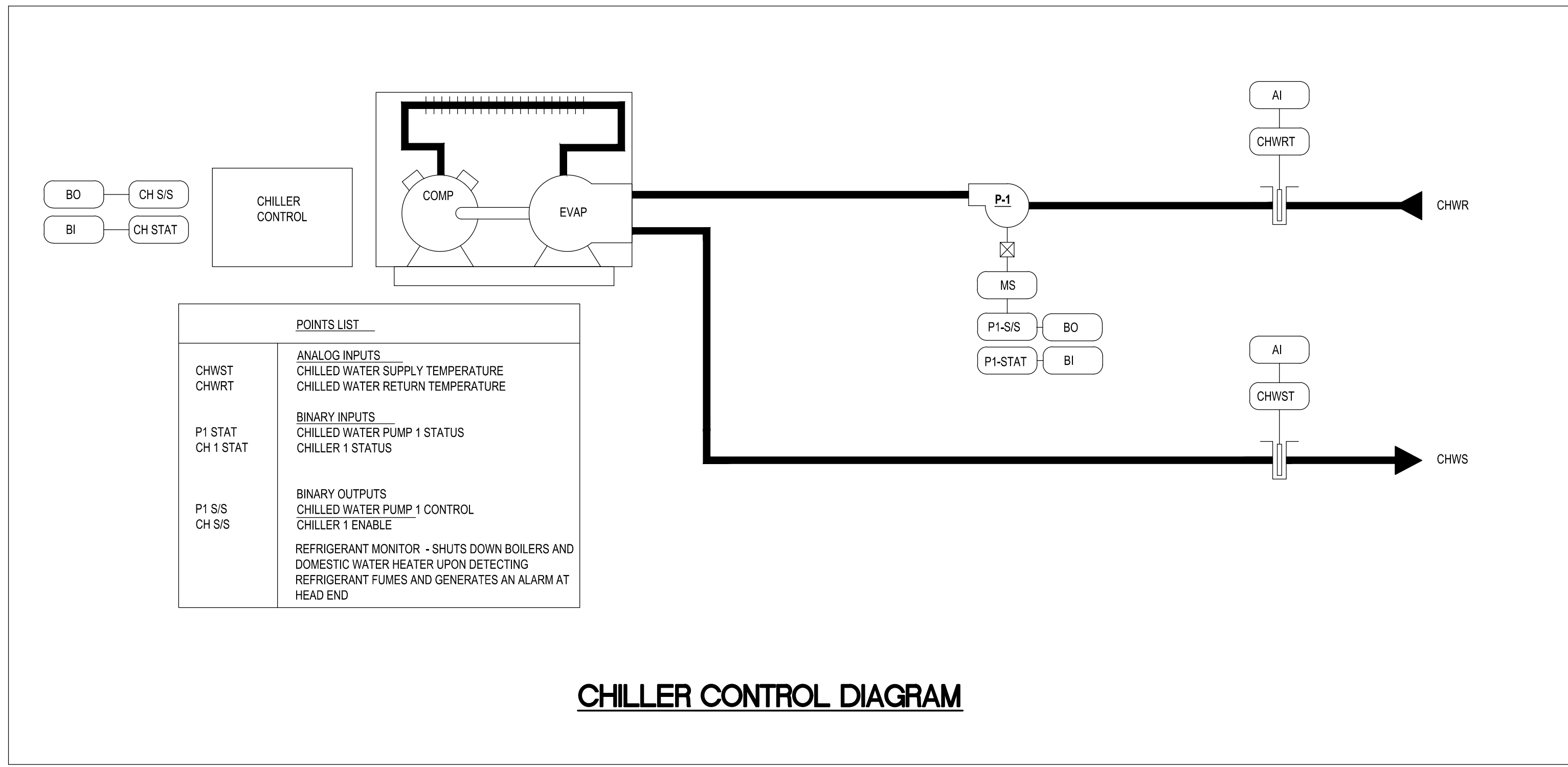
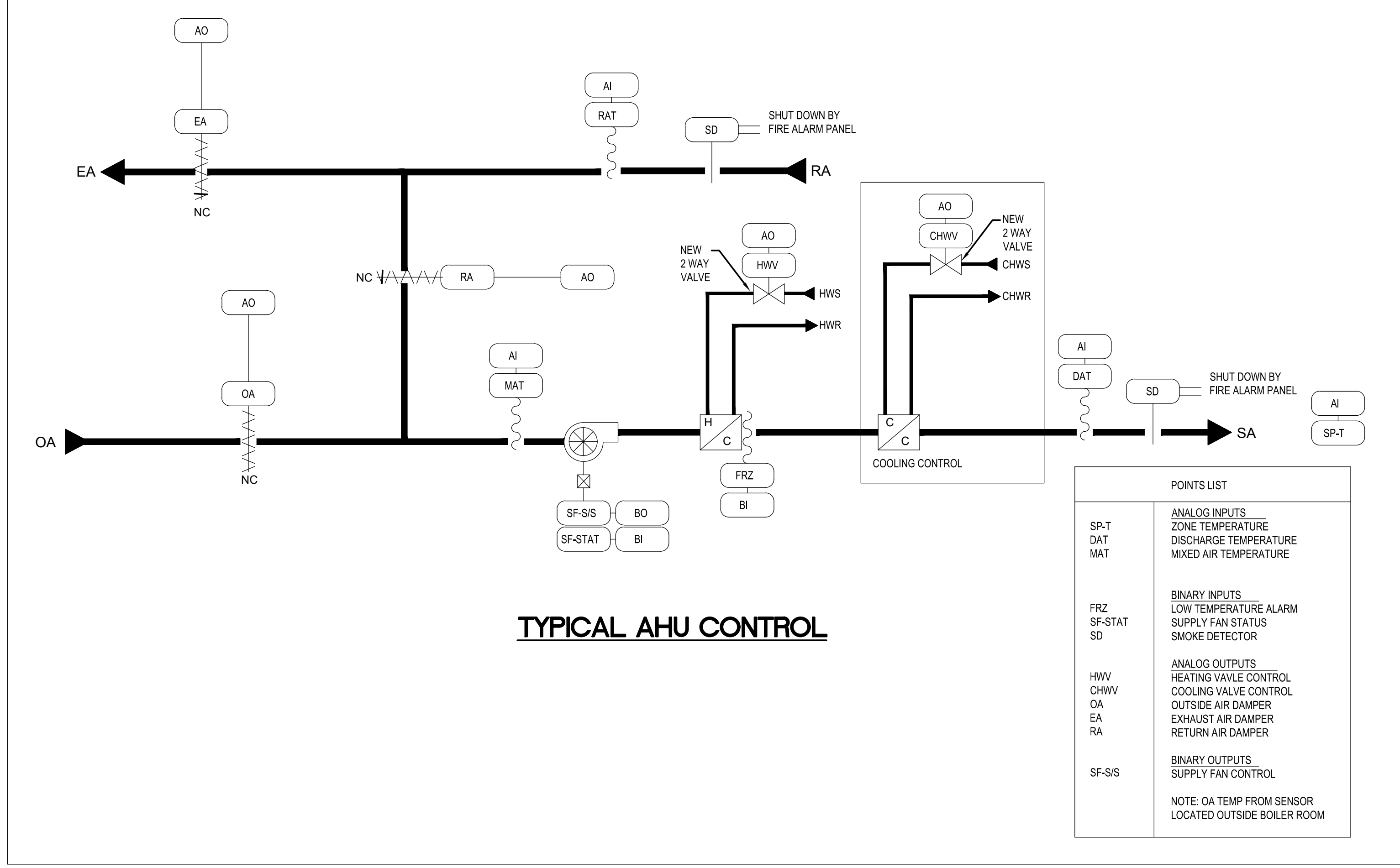
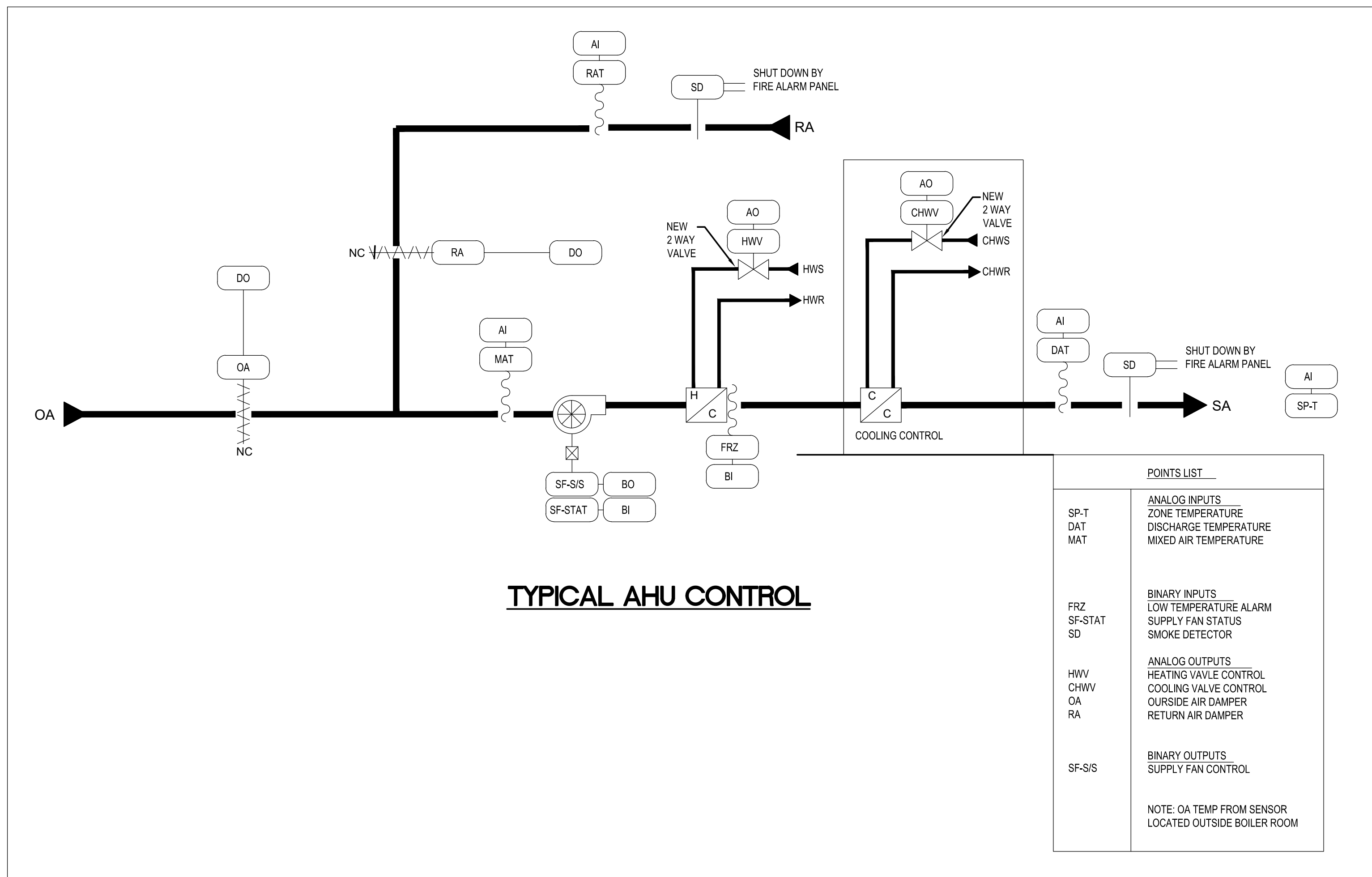

GENERAL DRAWING NOTES:

- ALL ELECTRIC WIRING CONNECTIONS, DEVICES, RACEWAY AND HARDWARE REQUIRED FOR THE INSTALLATION OF THE TEMPERATURE CONTROL SYSTEM AS SPECIFIED AND SHOWN ON THE DRAWINGS SHALL BE PROVIDED BY THE TEMPERATURE CONTROLS CONTRACTOR (TCC).
- ALL CONTROL WIRING SHALL BE INSTALLED IN ACCORDANCE WITH THE CONTROL SYSTEM MANUFACTURER'S REQUIREMENTS AND CURRENT CODES.
- ALL LOW VOLTAGE CONTROL WIRING SHALL BE PLENUM RATED CABLE OF TYPES AND SIZES REQUIRED BY THE CONTROL SYSTEM MANUFACTURER. PROVIDE MINIMUM OF 3/4" EMT CONDUIT FOR ALL WIRING EXPOSED TO VIEW AND FOR WIRING DROPS AND RUNS WITHIN WALLS. EMT FITTINGS AND CONNECTORS SHALL BE STEEL SET SCREW TYPE.
- ALL CONDUITS SHALL TERMINATE WITH JUNCTION BOXES OR OUTLET BOXES. PROVIDE BUSHINGS FOR ALL WIRING ENTRIES INTO THE CONDUIT SYSTEM.
- ALL TEMPERATURE CONTROL WIRING SHALL BE NEATLY INSTALLED WITH CABLE RUNS INSTALLED PARALLEL TO OR AT RIGHT ANGLES TO THE LINES OF THE BUILDING. ALL WIRING IN NORMALLY OCCUPIED AREAS OF THE BUILDING SHALL BE CONCEALED FROM VIEW. OPEN CABLE RUNS ABOVE CEILING SHALL BE BUNDLE TIED WITH PLASTIC CABLE TIES AND SHALL BE SUPPORTED FREE FROM THE CEILING AND MECHANICAL/ELECTRICAL EQUIPMENT USING APPROVED CABLE HANGERS AND CABLE CLIPS.
- THE TEMPERATURE CONTROL CONTRACTOR SHALL COORDINATE POWER SUPPLY REQUIREMENTS OF THE CONTROL SYSTEM WITH DIVISION 28.
- REFER TO SPECIFICATION FOR ADDITIONAL CONTROLS REQUIREMENTS AND THE EQUIPMENT SEQUENCE OF OPERATIONS.
- ALL CONTROLS DEVICES AND ELECTRONICS SHALL BE INSTALLED WITHIN A NEMA-1 ENCLOSURE LOCATED WITHIN PROXIMITY TO THE EQUIPMENT SERVED.
- REFER TO MECHANICAL SPECIFICATIONS FOR SEQUENCE OF OPERATIONS AND ADDITIONAL DOC SENSORS REQUIREMENT.

TITLE
MECHANICAL
TEMPERATURE
CONTROL DIAGRAMS

DATE 03/14/2024

DWG. NO.
M3.1

ELECTRICAL DEMOLITION WORK NOTES	
1-	PRIOR TO SUBMITTING BID, VISIT THE SITE AND IDENTIFY EXISTING CONDITIONS AND DIFFICULTIES THAT WILL AFFECT WORK TO BE PERFORMED. NO COMPENSATION WILL BE GRANTED FOR ADDITIONAL WORK CAUSED BY UNFAMILIARITY WITH SITE CONDITIONS THAT ARE VISIBLE OR READILY CONSTRUED BY EXPERIENCED OBSERVERS. INCLUDE IN THE BID ALL DEMOLITION WORK REQUIRED.
2-	THE DEMOLITION DRAWINGS ARE INTENDED ONLY TO DEFINE THE GENERAL SCOPE OF DEMOLITION WORK AND TO ASSIST THE CONTRACTOR DURING BIDDING. THE DEMOLITION DRAWINGS MAY NOT SHOW EVERY ITEM WHICH MUST BE DISCONNECTED, REMOVED, OR RELOCATED IN ORDER TO FACILITATE NEW WORK. THE CONTRACTOR SHALL BE RESPONSIBLE FOR ALL DEMOLITION WORK REQUIRED WHETHER OR NOT SHOWN ON THE PLANS.
3-	REMOVE AND/OR RELOCATE ALL EXISTING ELECTRICAL WORK AS NECESSARY FOR THE PERFORMANCE OF THE WORK OF THIS CONTRACT.
4-	EXISTING ELECTRICAL EQUIPMENT, WIRING, AND RACEWAYS SHALL NOT BE REUSED UNLESS SPECIFICALLY NOTED OTHERWISE.
5-	REMOVE ALL DEMOLITION MATERIAL FROM THE JOB SITE UNLESS NOTED DIFFERENTLY. MATERIAL REQUESTED BY THE OWNER FOR SALVAGE SHALL BE DELIVERED TO THE OWNER'S DESIGNATED MATERIAL STORAGE AREA.
6-	PROVIDE WIRING AS REQUIRED AND RECONNECT EXISTING FIXTURES, DEVICES, OR EQUIPMENT THAT ARE TO REMAIN ACTIVE, BUT HAVE BEEN DISCONNECTED DURING DEMOLITION OF OTHER FIXTURES, DEVICES, OR EQUIPMENT.

ELECTRICAL KEY NOTES - DEMOLITION	
TAG	DESCRIPTION
1	DISCONNECT & REMOVE EXISTING BOILER ELECTRICAL. REMOVE EXISTING OBSOLETE WIRING BACK TO SOURCE PANEL. CUT BACK CONDUIT TO STRUCTURE, CAP & SECURE AS REQUIRED.
2	DISCONNECT & REMOVE EXISTING FUEL OIL DUPLEX PUMPS ELECTRICAL. REMOVE EXISTING OBSOLETE WIRING BACK TO SOURCE PANEL. CUT BACK CONDUIT TO STRUCTURE, CAP & SECURE AS REQUIRED.
3	DISCONNECT & REMOVE EXISTING BOILER CONTROL PANEL ELECTRICAL. REMOVE EXISTING OBSOLETE WIRING BACK TO SOURCE PANEL. CUT BACK CONDUIT TO STRUCTURE, CAP & SECURE AS REQUIRED.
4	DISCONNECT & REMOVE EXISTING BOILER PUMPS ELECTRICAL. REMOVE EXISTING OBSOLETE WIRING BACK TO VFD. REMOVE EXISTING OBSOLETE CONDUIT.
5	DISCONNECT & REMOVE EXISTING BOILER PUMPS ELECTRICAL (VFD & DISCONNECT SWITCH). REMOVE EXISTING OBSOLETE WIRING BACK TO DISCONNECT. EXISTING HOME RUN TO BE RE-USED MAKE SAFE FOR NEW CONSTRUCTION.
6	DISCONNECT & REMOVE EXISTING EMERGENCY OFF SWITCH AND ALL OBSOLETE WIRING. CUT BACK CONDUIT TO STRUCTURE, SECURE & CAP AS REQUIRED.

ELECTRICAL KEY NOTES - NEW WORK	
TAG	DESCRIPTION
1	NEW BOILER PUMP 7.5HP @ 480V-3Ø CONNECT TO EXISTING PUMP BRANCH CIRCUIT MADE AVAILABLE BY REMOVAL THROUGH NEW VFD & CONNECT AS REQUIRED FOR A COMPLETE INSTALLATION.
2	NEW BOILER EXTEND 2Ø12, 1Ø12X IN 3/4" TO NEW 1Ø-2ØA CIRCUIT BREAKER IN EXISTING PANEL EVLA THROUGH NEW EMERGENCY OFF SWITCH & CONNECT AS REQUIRED. NEW CIRCUIT BREAKER SHALL MATCH EXISTING PANEL MANUFACTURER & AIC RATING (VERIFY IN FIELD).
3	FURNISH & INSTALL NEW 2-POLE EMERGENCY OFF SWITCH IN SPACE MADE AVAILABLE BY REMOVAL OF EXISTING.
4	PROVIDE A NEW CARBON MONOXIDE DETECTOR ALONG WITH A NEW FIRE ALARM MONITOR MODULE, WIRING CONDUIT, AND CONNECTIONS AS REQUIRED TO CONNECT THE CARBON MONOXIDE DETECTOR TO THE EXISTING FIRE ALARM SYSTEM. THE CARBON MONOXIDE DETECTOR IS TO INITIATE A SUPERVISORY SIGNAL AT THE FIRE ALARM CONTROL PANEL UPON ACTIVATION. SUPERVISORY ALARM SHALL NOTIFY THE MONITORING COMPANY OR DISPATCH. PROVIDE 120V POWER AS REQUIRED FOR THE DETECTOR.

ELECTRICAL DRAWING LEGEND	
SYMBOLS	
S	SINGLE POLE TOGGLE SWITCH, MOUNT WITH TOP AT 48" AFF.
S _{EO}	BOILER EMERGENCY OFF SWITCH, MOUNT AT 60" AFF.
S _T	MOTOR RATED THERMAL OVERLOAD SWITCH
⊕	EQUIPMENT POWER CONNECTION, EQUIPMENT TYPE AS DESIGNATED.
⊖	SOLID STATE CONTACTOR
⊕	MOTOR POWER CONNECTION, EQUIPMENT TYPE AS DESIGNATED.
⊖	CARBON MONOXIDE DETECTOR.
⊖	DISCONNECT SWITCH.
⊖	VARIABLE FREQUENCY DRIVE (VFD).
⊖	VARIABLE FREQUENCY DRIVE (VFD) WITH INTEGRAL DISCONNECT.
⊖	2Ø8Y120V-3Ø-4W PANELBOARD.
⊖	4ØY277V-3Ø-4W PANELBOARD.
⊖	BRANCH CIRCUIT WIRING IN CONDUIT, CROSS LINES INDICATE NUMBER OF CONDUCTORS.
⊖	BRANCH CIRCUIT HOMERUN IN CONDUIT, CROSS LINES INDICATE NUMBER OF CONDUCTORS.
ABBREVIATIONS	
A	AMPS.
AC	ABOVE COUNTER.
AFF	ABOVE FINISHED FLOOR (CENTERLINE OF DEVICE OR EQUIPMENT).
AWG	AMERICAN WIRE GAUGE.
C	CONDUIT.
C/B	CIRCUIT BREAKER.
(E)	EXISTING
GFCI	INDICATES DEVICE WITH INTEGRAL GROUND FAULT CIRCUIT INTERRUPTER.
GND or G	GROUND.
JB	JUNCTION BOX.
LV	LOW VOLTAGE.
NTS	NOT TO SCALE.
VFD	VARIABLE FREQUENCY DRIVE.

GENERAL NOTES - POWER	
1-	THE CONTRACTOR SHALL VERIFY AND OBTAIN ALL NECESSARY DIMENSIONS AT THE BUILDING.
2-	FINISHED WORK, THE INTENT OF THE SPECIFICATIONS AND DRAWINGS IS TO CALL FOR FINISHED WORK, COMPLETED, TESTED AND READY FOR OPERATION.
3-	GOOD PRACTICE: IT IS NOT INTENDED THAT THE DRAWINGS SHOW EVERY CONDUIT, JUNCTION BOX, FITTING OR MINOR DETAIL AND IT IS UNDERSTOOD THAT WHILE THE DRAWINGS MUST BE FOLLOWED AS CLOSELY AS CIRCUMSTANCES WILL PERMIT, THE SYSTEMS SHALL BE INSTALLED ACCORDING TO THE INTENT AND MEANING OF THE CONTRACT DOCUMENTS AND IN ACCORDANCE WITH GOOD PRACTICE.
4-	ANY APPARATUS, APPLIANCE MATERIAL OR WORK NOT SHOWN ON DRAWINGS BUT MENTIONED IN SPECIFICATIONS OR VICE VERSA, OR ANY INCIDENTAL ACCESSORIES NECESSARY TO MAKE THE WORK COMPLETE AND PERFECT IN ALL RESPECTS AND READY FOR OPERATION, EVEN IF NOT PARTICULARLY SPECIFIED, SHALL BE FURNISHED AND INSTALLED BY CONTRACTOR AT NO ADDITIONAL COST TO OWNER.
5-	CODES AND STANDARDS - COMPLY WITH ALL FEDERAL, STATE AND LOCAL CODES AND STANDARDS WHEREVER APPLICABLE INCLUDING THE FOLLOWING: 2018 CONNECTICUT STATE BUILDING CODE, 2015 INTERNATIONAL BUILDING CODE, 2018 CONNECTICUT FIRE SAFETY CODE, 2015 INTERNATIONAL FIRE CODE, 2013 NFPA 72 NATIONAL FIRE ALARM CODE, 2017 NFPA 70 NATIONAL ELECTRICAL CODE, 2010 NFPA 110 STANDARD FOR EMERGENCY AND STANDBY POWER SYSTEMS, 2015 INTERNATIONAL ENERGY CONSERVATION CODE, ICC/ANSI A117.1-2009 ACCESSIBLE AND USABLE BUILDINGS AND FACILITIES, ADA, NFPA, UNDERWRITERS LABORATORIES, FACTORY MUTUAL INSURANCE COMPANY, NEMA STANDARDS.
6-	NOTE THAT THE DRAWINGS ARE DIAGRAMMATIC AND INDICATE THE GENERAL ARRANGEMENT OF THE ELECTRICAL EQUIPMENT AND SYSTEMS, WITHOUT SHOWING EVERY DETAIL AND FITTING.
7-	RACEWAYS: PROVIDE EMT CONDUIT FOR ALL WIRING. EMT CONNECTORS AND COUPLINGS SHALL BE GALVANIZED STEEL, SET-SCREW TYPE. PROVIDE GLAND COMPRESSION CONNECTORS AND COUPLINGS WHERE LOCATED IN 5/8" AND 1/2" LOCATIONS. PROVIDE FLEXIBLE STEEL CONDUIT FOR FINAL CONNECTIONS TO MOTOR DRIVEN EQUIPMENT. PROVIDE LIQUID TIGHT FLEXIBLE STEEL CONDUIT FOR FINAL CONNECTIONS TO MOTOR DRIVEN EQUIPMENT LOCATED OUTDOORS.
8-	BRANCH CIRCUIT CONDUCTORS SHALL BE COPPER, RATED 90 VOLTS, 90 DEG C, COLOR CODED, TYPE THWN-2.
9-	WIRE SIZE #8 AWG AND LARGER SHALL BE STRANDED, WIRE OF SIZE SMALLER THAN #8 AWG SHALL BE SOLID.
10-	MINIMUM SIZE CONDUCTORS FOR POWER AND LIGHTING SHALL BE #12 AWG. PROVIDE MINIMUM #10 AWG SIZE FOR RUNS EXCEEDING 75' IN CONDUCTOR LENGTH, AND #8 AWG SIZE FOR RUNS EXCEEDING 150' IN CONDUCTOR LENGTH. PROVIDE LARGER SIZE CONDUCTORS AS SCHEDULED OR AS NOTED ON THE DRAWINGS.
11-	THE NUMBER OF WIRES IN A CONDUIT RUN IS INDICATED ON THE DRAWINGS BY CROSS LINES ON THE CONDUIT RUNS. PROVIDE CODE-SIZED CONDUIT FOR THE NUMBER AND SIZE OF WIRES UNLESS A LARGER SIZE IS SHOWN ON THE DRAWINGS. MINIMUM CONDUIT SIZE SHALL BE 3/4".
12-	RACEWAYS SHALL BE CONCEALED WHEREVER POSSIBLE IN ALL FINISHED AREAS.
13-	RACEWAYS SHALL BE RUN PARALLEL TO OR AT RIGHT ANGLES TO WALL LINES.
14-	RACEWAYS SHALL BE SUPPORTED FROM THE STRUCTURE BY STRAP HANGERS, ROD HANGERS, OR RACK MOUNTED, OR OTHER APPROVED ELECTRICAL MOUNTING.
15-	PROVIDE FIRE STOPPING AT ALL FIRE AND/OR SMOKE RATED WALL OR CEILING PENETRATIONS IN ORDER TO MAINTAIN ITS ORIGINAL INTEGRITY.
16-	OUTLET JUNCTION, AND PULL BOXES SHALL BE CODE GAUGE GALVANIZED STEEL AND SHALL BE OF SHAPES AND SIZES TO SUIT THEIR RESPECTIVE LOCATIONS AND INSTALLATIONS, AND SHALL BE PROVIDED WITH COVERS TO SUIT THEIR FUNCTION AND INSTALLATION. PROVIDE CAST BOXES FOR OUTDOOR WORK.
17-	THE CONTRACTOR SHALL ASSUME THAT THE EXISTING BUILDING WIRING SYSTEM UTILIZES A CONDUIT GROUND. THE CONTRACTOR SHALL MAINTAIN ADEQUATE GROUND CONTINUITY FOR ALL NEW WORK.

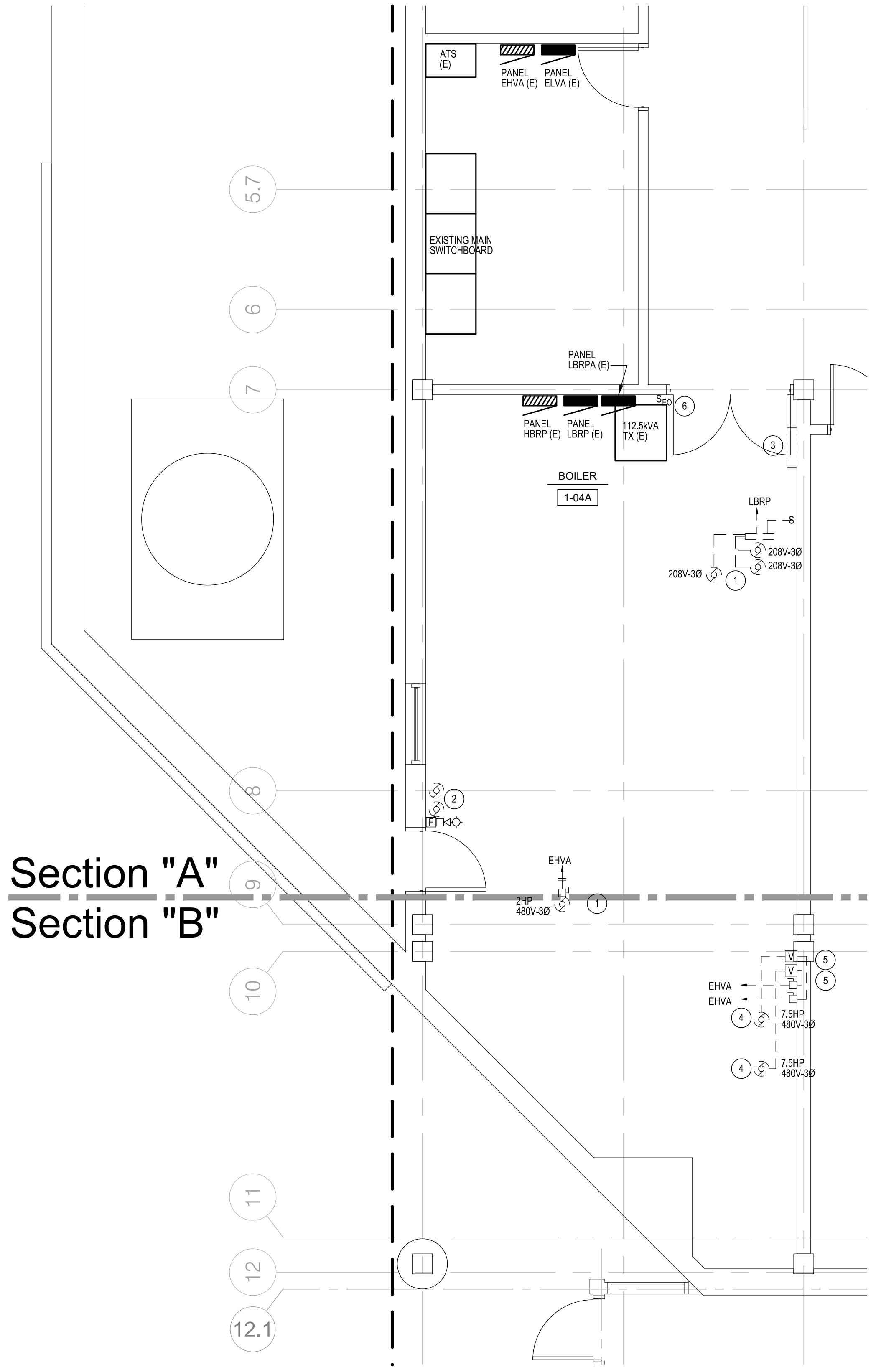

BOILER ROOM PART PLAN - ELECTRICAL DEMOLITION
SCALE: 1/4"=1'-0"

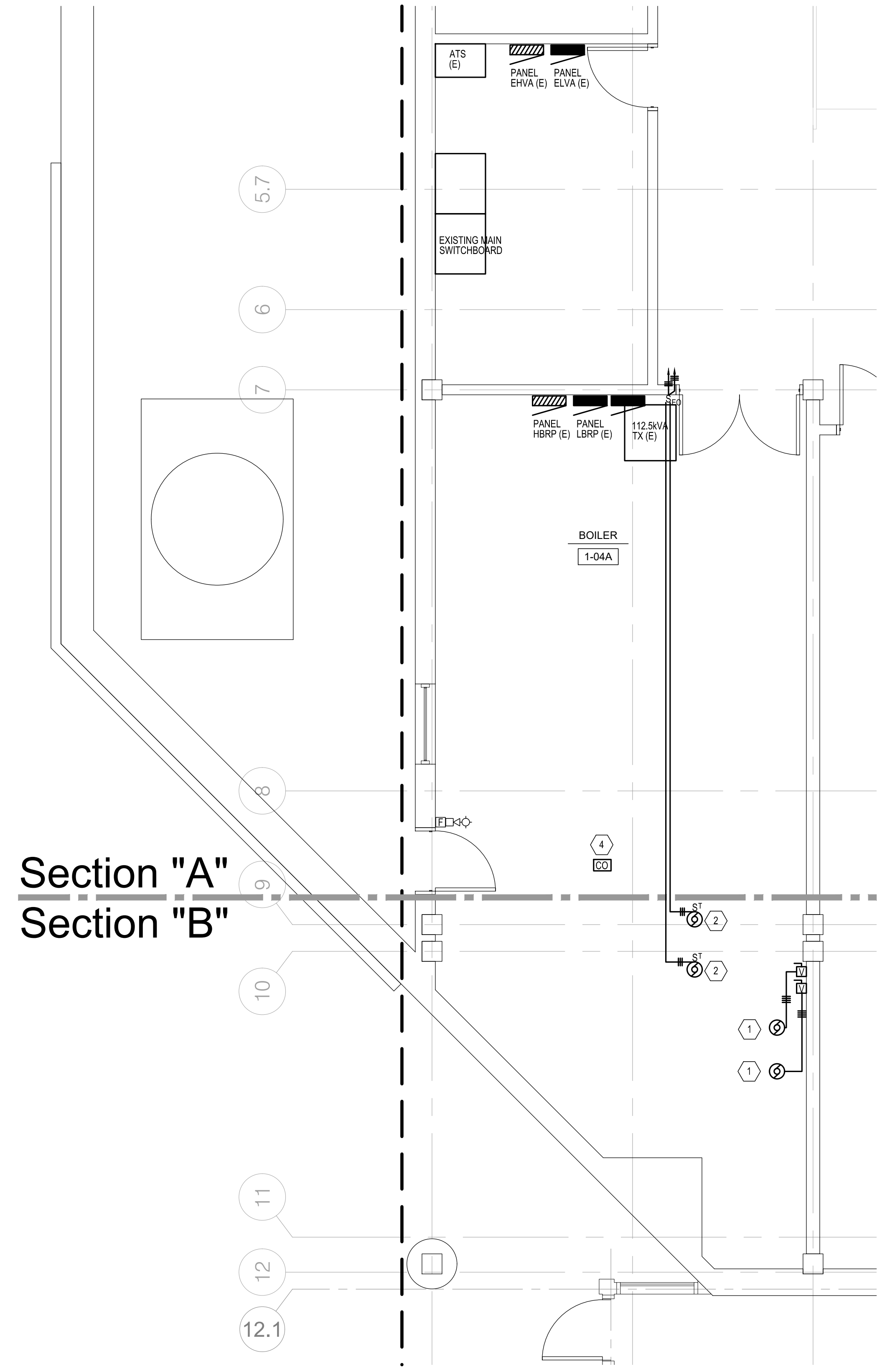

BOILER ROOM PART PLAN - ELECTRICAL NEW WORK
SCALE: 1/4"=1'-0"

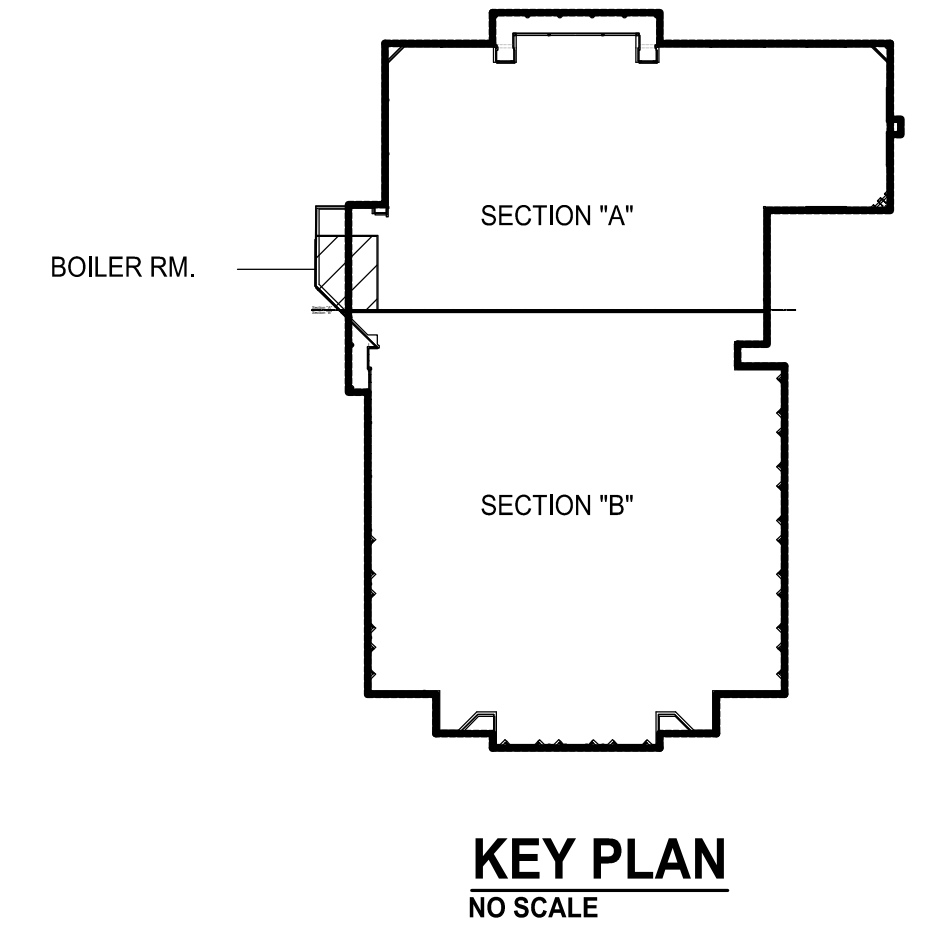

COPYRIGHT
The drawing is the property of BEMIS ASSOCIATES, L.L.C. and shall remain the property of BEMIS ASSOCIATES, L.L.C. No part of this drawing may be reproduced, stored in a retrieval system, or transmitted in any form or by any means, electronic, mechanical, photocopying, recording, or by any information storage and retrieval system, without the prior written permission of BEMIS ASSOCIATES, L.L.C. All rights reserved. BEMIS ASSOCIATES, L.L.C. is not responsible for any errors or omissions in this drawing. Any adjustment or violation of the rights of BEMIS ASSOCIATES, L.L.C. shall be deemed to be a violation of the terms of this agreement.

**WASHINGTON MIDDLE SCHOOL
BOILER REPLACEMENT**
MERIDEN, CONNECTICUT

BEMIS ASSOCIATES, L.L.C.
Consulting Engineers
185 Main Street
Farmington, CT 06032
Tel: (860) 321-7770
Fax: (860) 321-7770
www.bemisassociates.com

TITLE
**BOILER ROOM
ELECTRICAL
DEMOLITION and
NEW WORK**

DATE: 03/14/2024

DWG. NO.
E0.1